

Home Capri

Home Capri / Capri Home

Versão 1.0 / Versión 1.0 / Version 1.0

www.artely.com.br

Conservação e Limpeza

Conservación y Limpieza Conservation and Cleaning

Não expor o produto ao sol, altas temperaturas e umidade. Não arrastar objetos sobre a superfície do móvel (ex.: TV, DVD, aparelho de som, objetos decorativos...) e manter em local seco e arejado.

Para a limpeza, utilizar um pano seco e macio. Não é necessário o uso de materiais abrasivos ou álcool.

No exponga el producto a la luz solar, las altas temperaturas y la humedad. No arrastre los objetos a través de la superficie de la unidad (por ejemplo, TV, DVD, equipo de música, objetos de decoración ...) Mantener en un lugar fresco y seco.

Para la limpieza, utilizar un paño seco y suave. El uso de materiales abrasivos o del alcohol no es necesario.

Do not expose the product to sunlight, high temperatures and humidity. Do not drag objects across the surface of the unit (TV, DVD, stereo, decorative objects ...) keep it in a cool dry place.

For cleaning, use a dry and soft cloth. Do not use abrasive materials or alcohol.

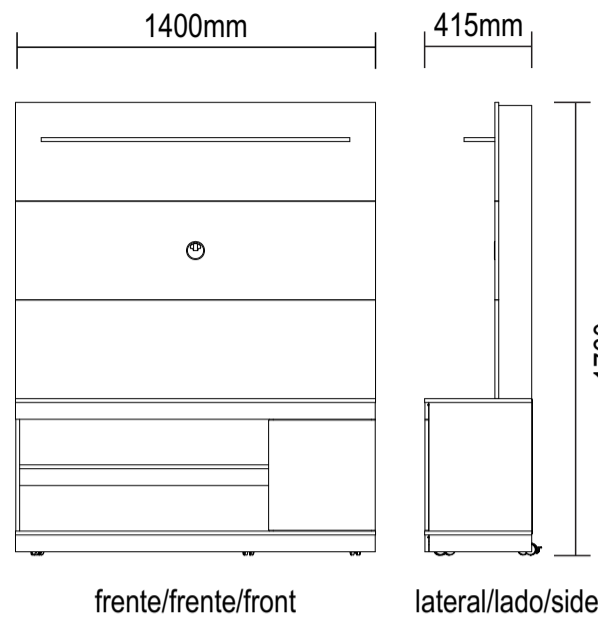







frente/frente/front



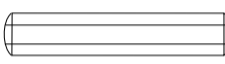

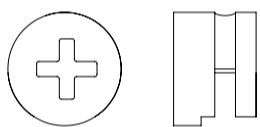

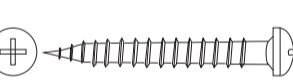
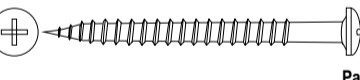

lateral/lado/side

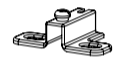

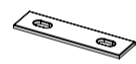
Lista de Materiais

Lista de Materiales/ Hardware List

A		Cavilha / Tarugo / Dowel Ø6x30mm	43
B		Minifix / Minifix / Minifix Ø7x30mm	28
C		Tambor / Tambor / Minifix Cam Ø15x12mm	28
D		Fixador / Fijador / Fixer	10
E		Prego / Clavo / Nail 8x8	40
F		Parafuso / Tornillo / Screw Ø4,0x14mm CP	58
G		Parafuso / Tornillo / Screw Ø4,0x30mm CP	10
H		Parafuso / Tornillo / Screw Ø3,5x40mm CP	16

I		Dobradiça / Bisagra / Hinge	02
J		Calço / Cuña de Bisagra / Hinge Shim	02
K		Suporte Angular / Soporte Angular / Plastic Corner Brace 24x16x13mm	06
L		Chapa Reta / Placa Recta / Mending Plate 50x13mm	04
M		Suporte Angular / Soporte Angular / Plastic Corner Brace	15
N		Rodizio RF40 s/ trava Rueda RF40 sin trava / RF40 Caster without lock Metal/Plástico - Metal/Plastico - Metal/Plastic 60x40mm	04
O		Bucha / Casquillo / Bushing Ø30x16mm Plástico / Plastico / Plastic	06
P		Rodizio RF40 c/ trava Rueda RF40 con trava / RF40 Caster with lock Metal/Plástico - Metal/Plastico - Metal/Plastic 70x40mm -	02
Q		Passa Fio / Pasacables / Cable Hole Cover Ø60mm	01

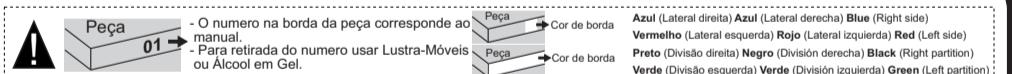
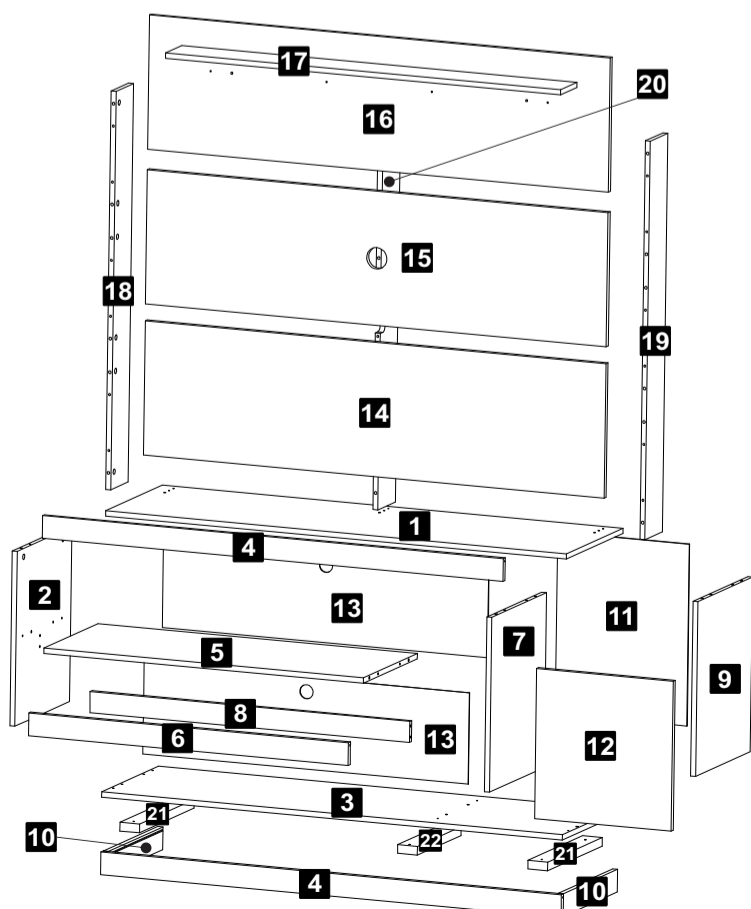

Descrição	Descripción	Description
1-Tampo (1400x416x15mm)	1-Tapa	1-Top
2-Lateral esq (500x400x15mm)	2-Lateral izquierda	2-Left side
3-Base (1400x416x15mm)	3-Base	3-Base
4-Encabeçamento (1399x65x15mm)	4-Encabezado	4-Header
5-Prateleira (971x396x15mm)	5-Anaqueel	5-Shelf
6-Encabeçamento prateleira (971x65x15mm)	6-Encabezado Anaqueel	6-Shelf header
7-Divisão (500x400x15mm)	7-Divisória	7-Partition
8-Travessa (971x60x15mm)	8-Travesaño	8-Crosspiece
9-Lateral dir (500x400x15mm)	9-Lateral derecha	9-Right side
10-Rodapé lateral (399x65x15mm)	10-Rodapié lateral	10-Side baseboard
11-Traseira (520x400x3mm)	11-Trasero	11-Back
12-Porta (429x415x15mm)	12-Puerta	12-Door
13-Traseira maior (988x261x3mm)	13-Trasero maior	13-Biger back
14-Painel inf (1400x384x15mm)	14-Panel inferior	14-Lower panel
15-Painel central (1400x384x15mm)	15-Panel central	15- Center panel
16-Painel sup (1400x384x15mm)	16-Painel superior	16-Upper panel
17-Prateleira sup (1200x120x15mm)	17-Anaqueel superior	17-Upper Shelf
18-Lateral sup esq (1140x128x15mm)	18-Lateral superior izquierda	18-Left upper side
19-Lateral sup dir (1140x128x15mm)	19-Lateral superior derecha	19-Right upper side
20-Divisão sup (1140x128x15mm)	20-Divisória superior	20-Upper partition
21-Travessa rodizio (400x60x25mm)	21-Travesaño ruedecilla	21-Caster crosspiece
22-Travessa rodizio central (320x60x25mm)	22-Travesaño ruedecilla central	22-Center caster crosspiece

Assista ao vídeo com dicas de montagem em nosso site: www.artely.com.br

1 Passo
Paso
Step

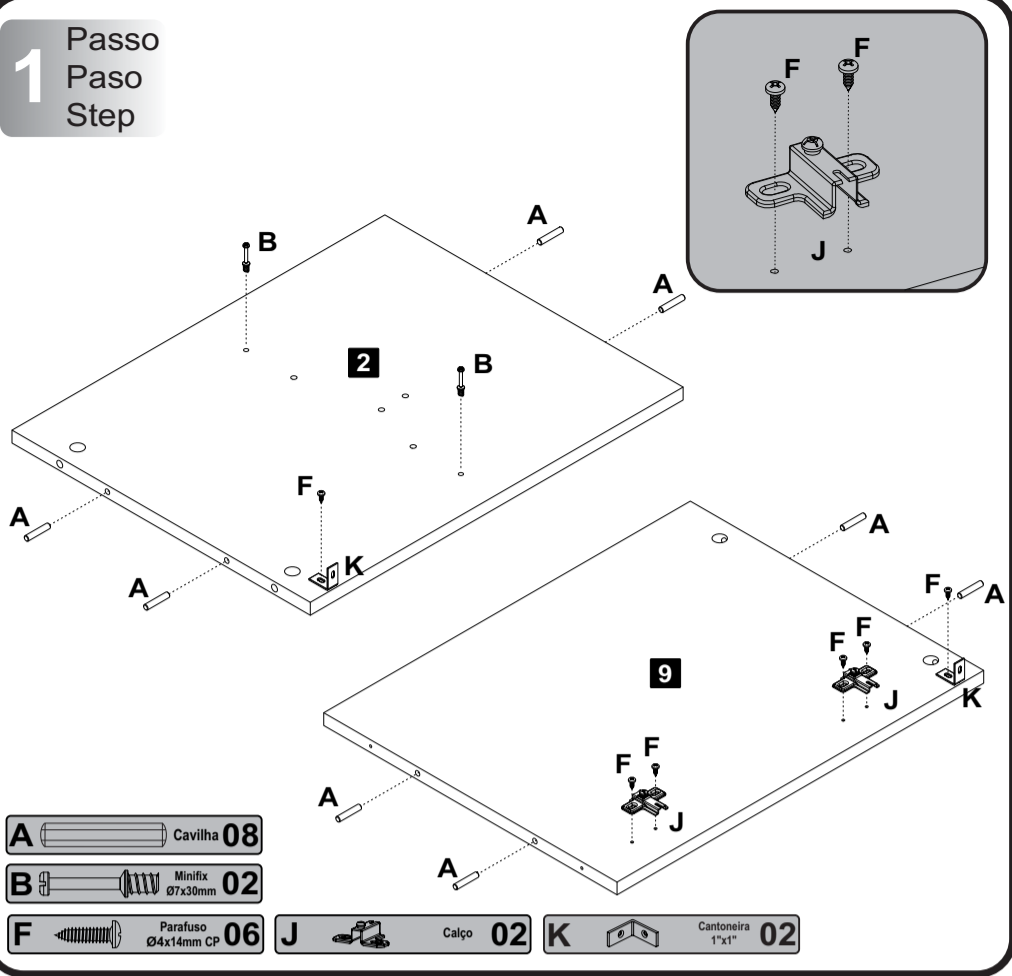

- A** Cavilha 08
- B** Minifix Ø7x30mm 02
- F** Parafuso Ø4x14mm CP 06
- J** Calço 02
- K** Cantoneira 1"x1" 02

2 Passo
Paso
Step

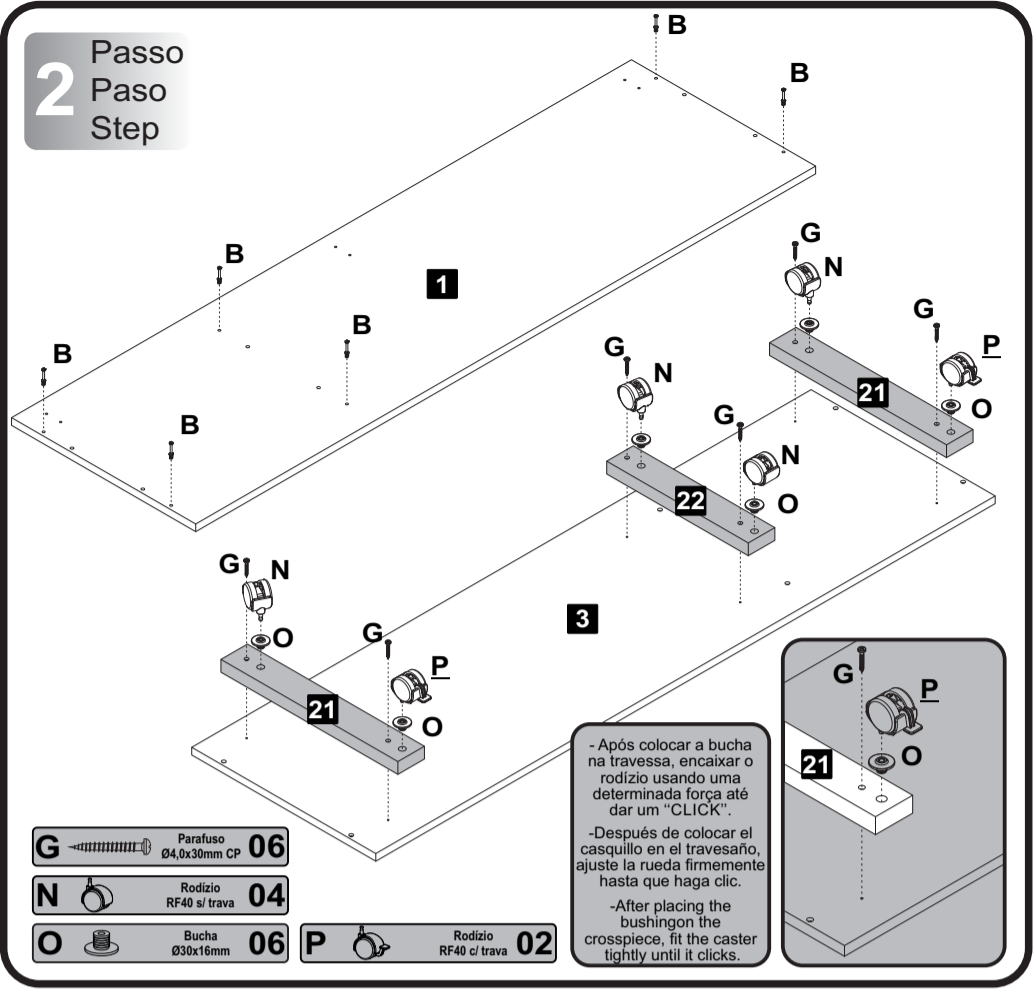

- G** Parafuso Ø4,0x30mm CP 06
- N** Rodízio RF40 sl trava 04
- O** Bucha Ø30x16mm 06
- P** Rodízio RF40 cl trava 02

- Após colocar a bucha na travessa, encaixar o rodízio usando uma determinada força até dar um "CLICK".
- Después de colocar el casquillo en el travesaño, ajuste la rueda firmemente hasta que haga clic.
- After placing the bushing on the crosspiece, fit the caster tightly until it clicks.

3 Passo
Paso
Step

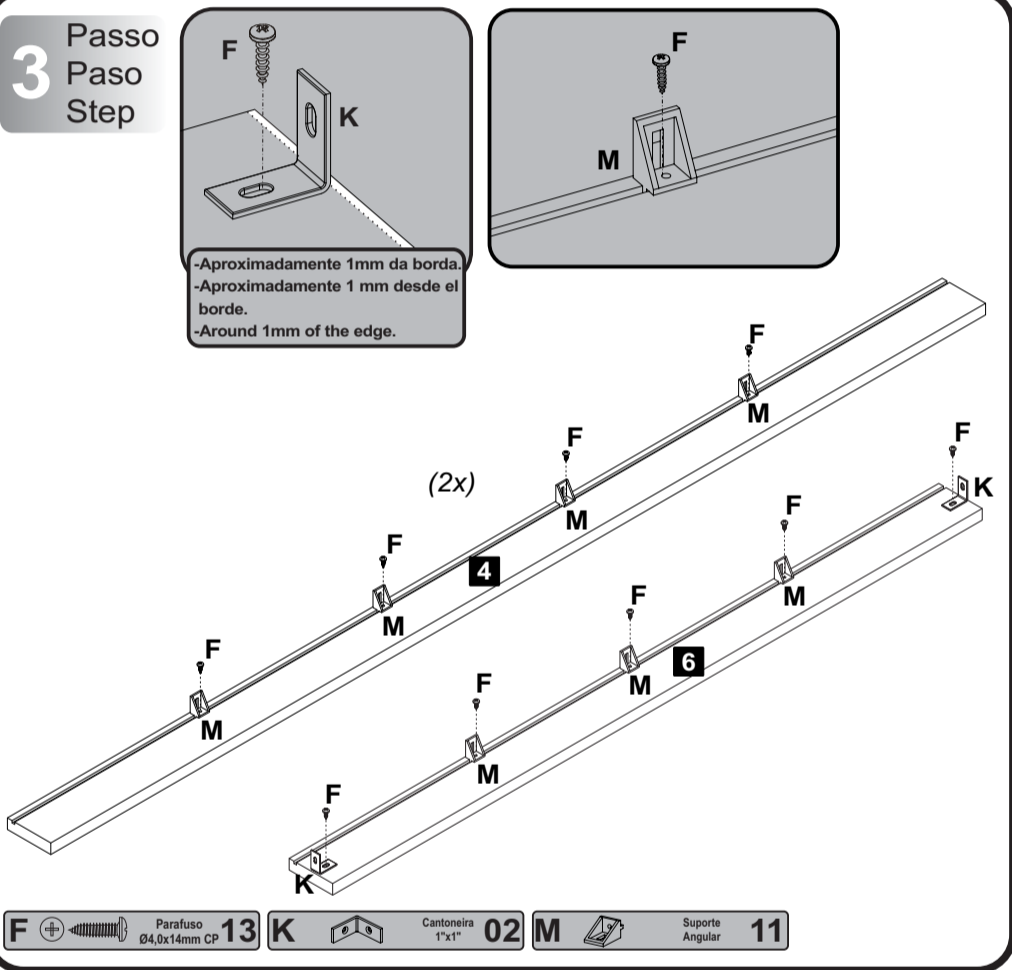

- F** Parafuso Ø4,0x14mm CP 13
- K** Cantoneira 1"x1" 02
- M** Suporte Angular 11

4 Passo
Paso
Step

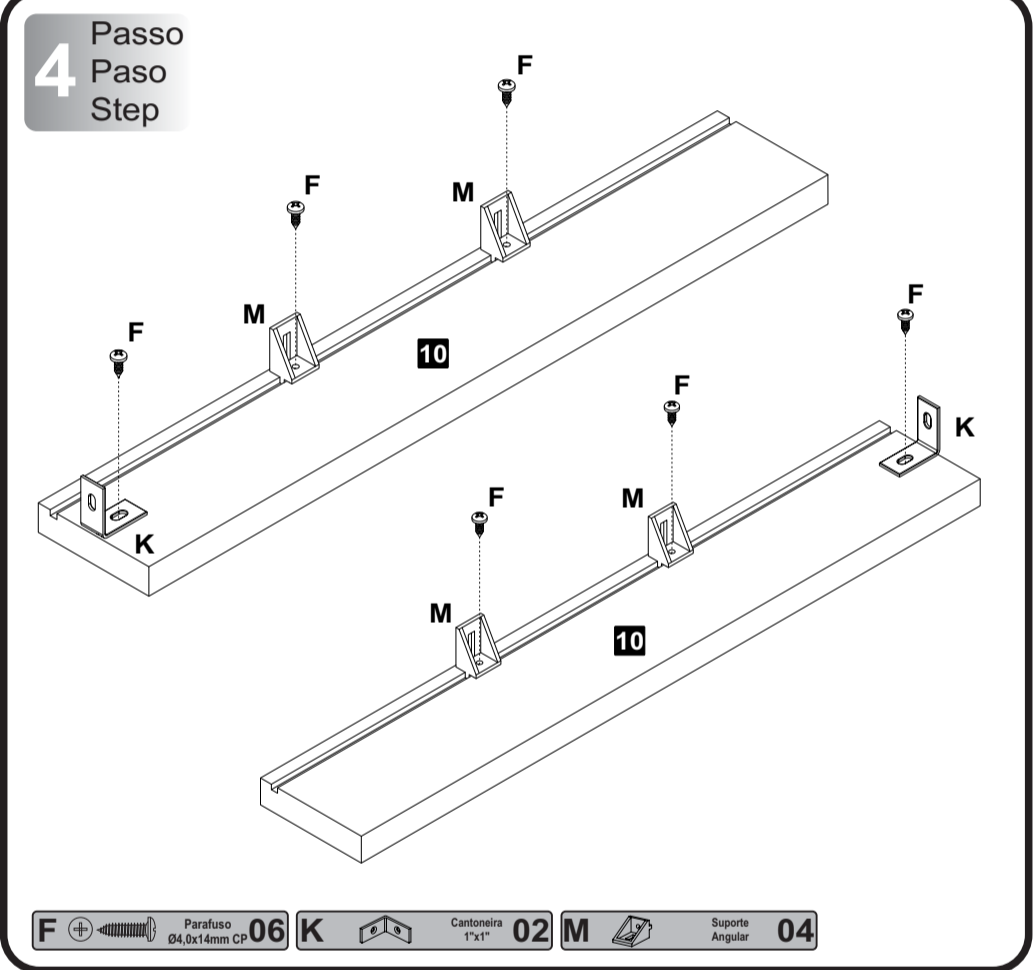

- F** Parafuso Ø4,0x14mm CP 06
- K** Cantoneira 1"x1" 02
- M** Suporte Angular 04

5 Passo
Paso
Step

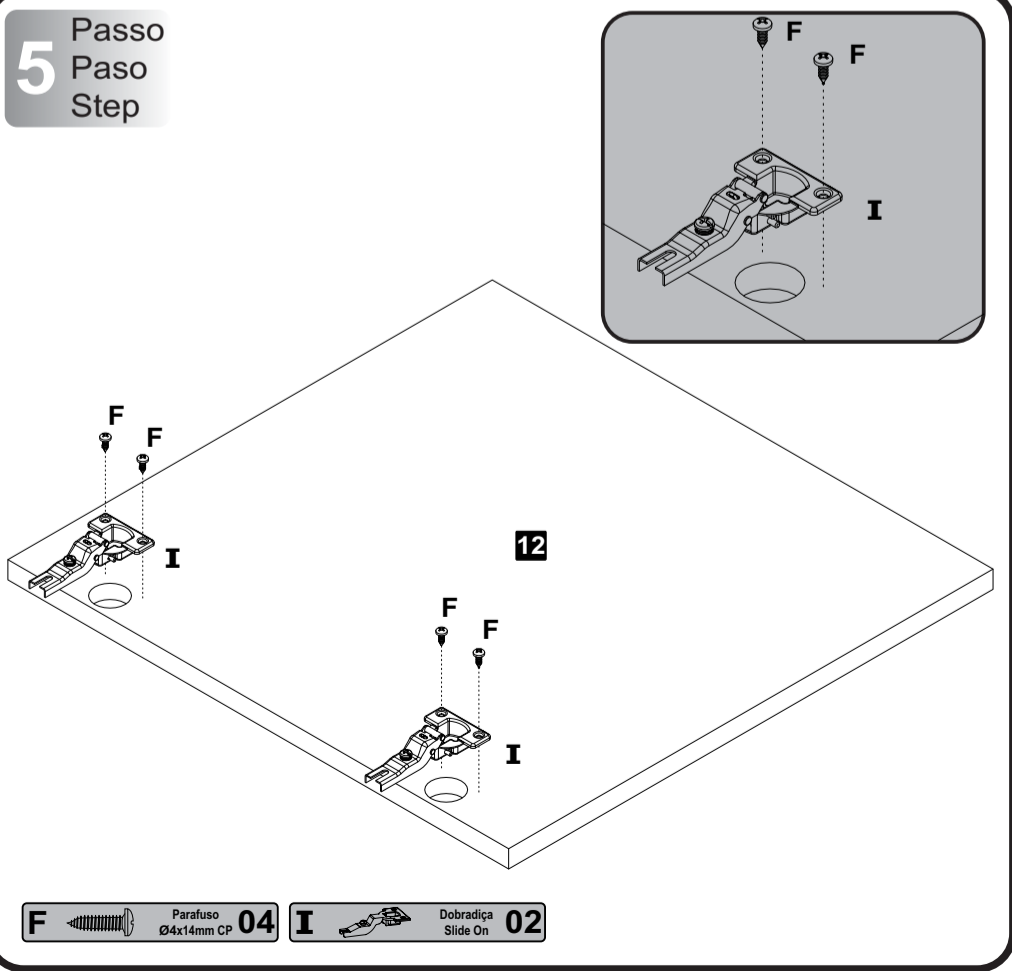

- F** Parafuso Ø4x14mm CP 04
- I** Dobradiça Slide On 02

6 Passo
Paso
Step

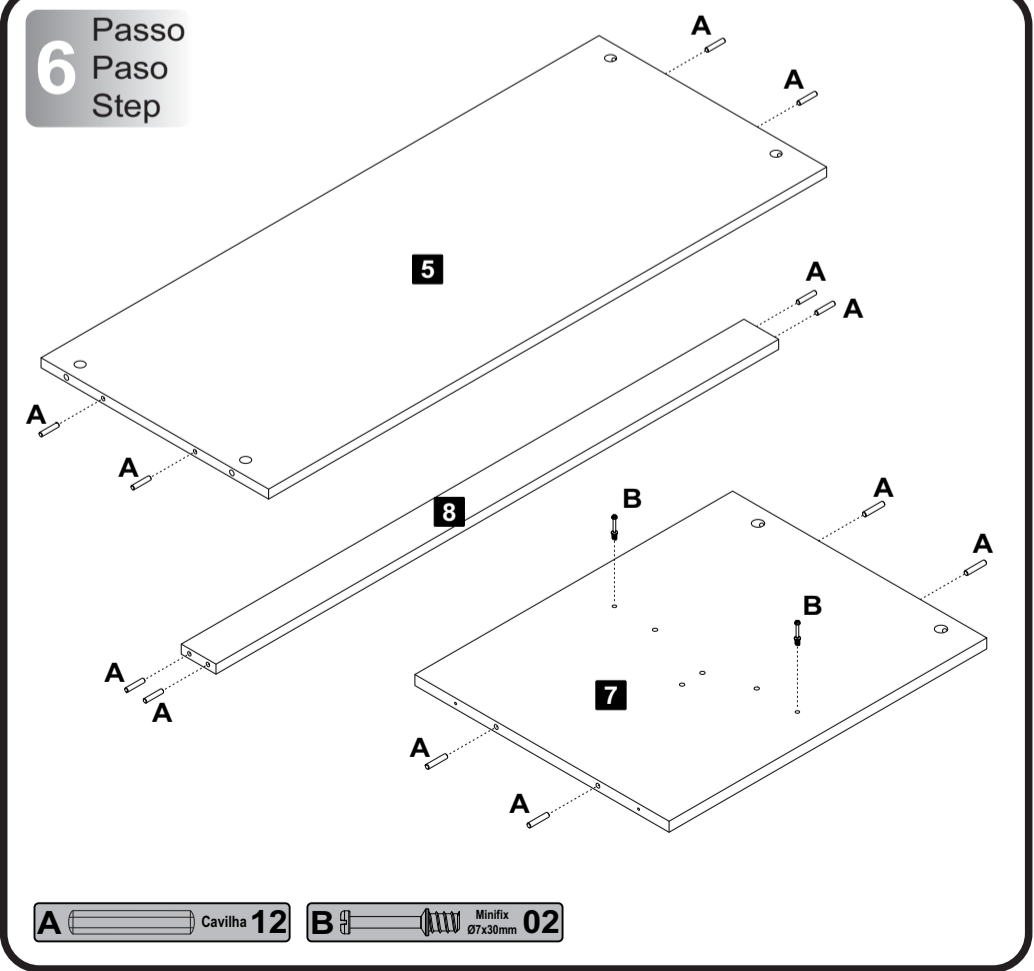

- A** Cavilha 12
- B** Minifix Ø7x30mm 02

7
Passo
Paso
Step

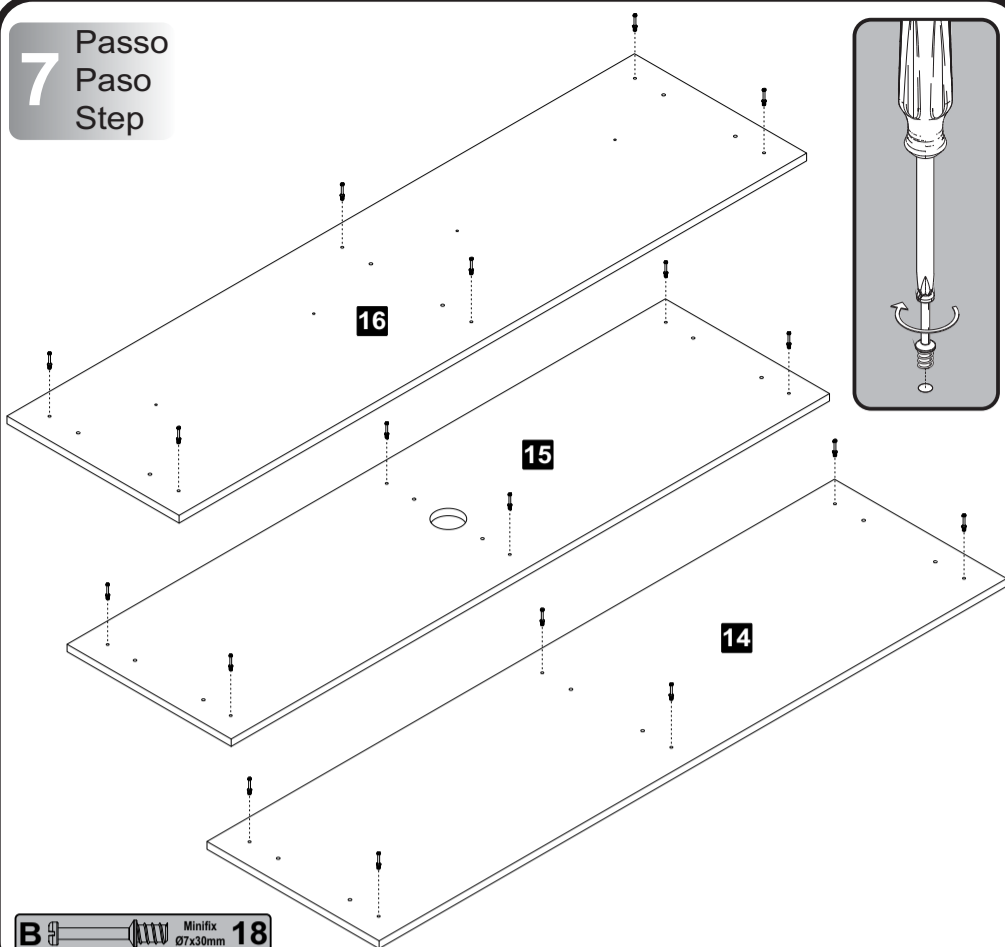

8
Passo
Paso
Step

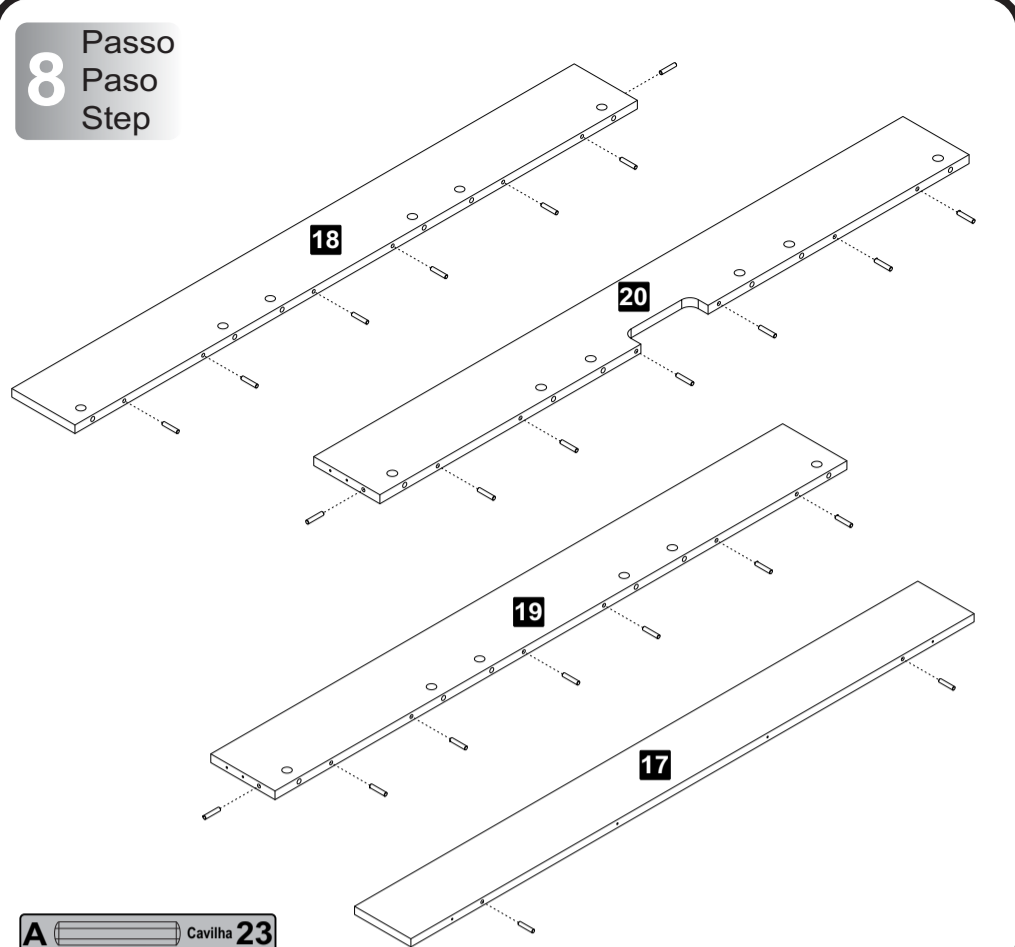

9
Passo
Paso
Step

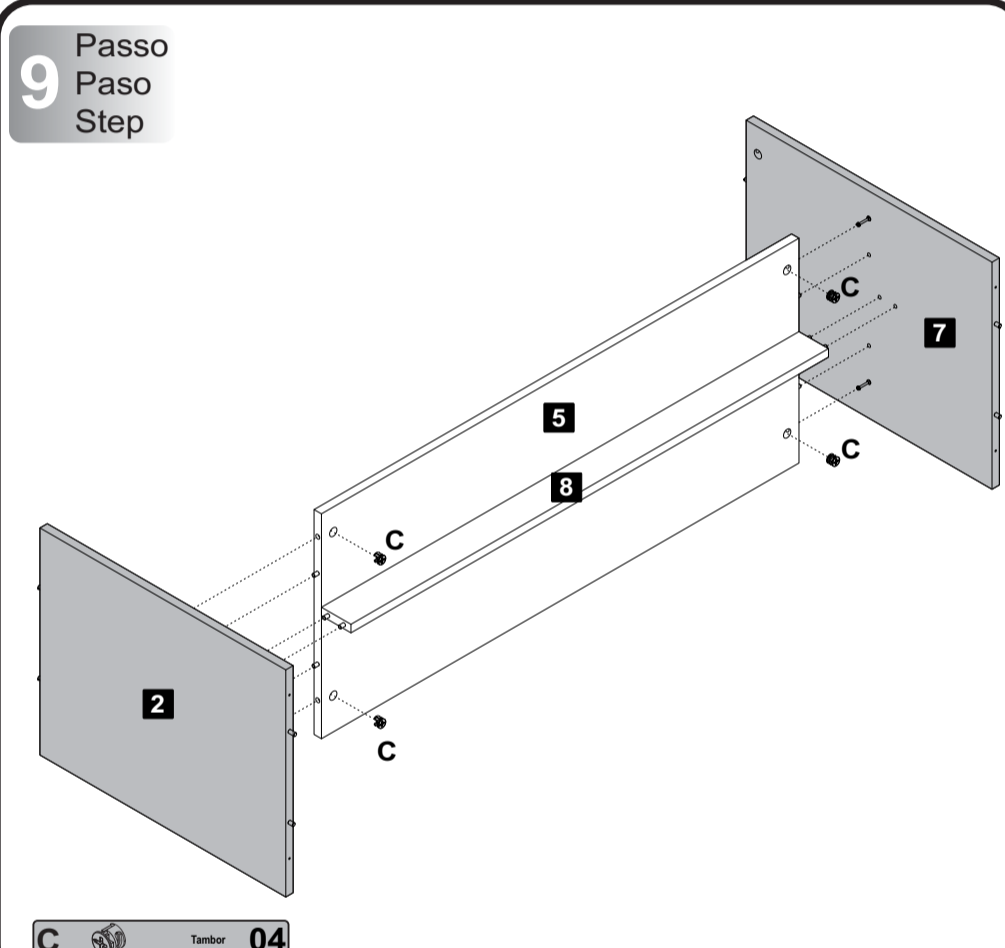

10
Passo
Paso
Step

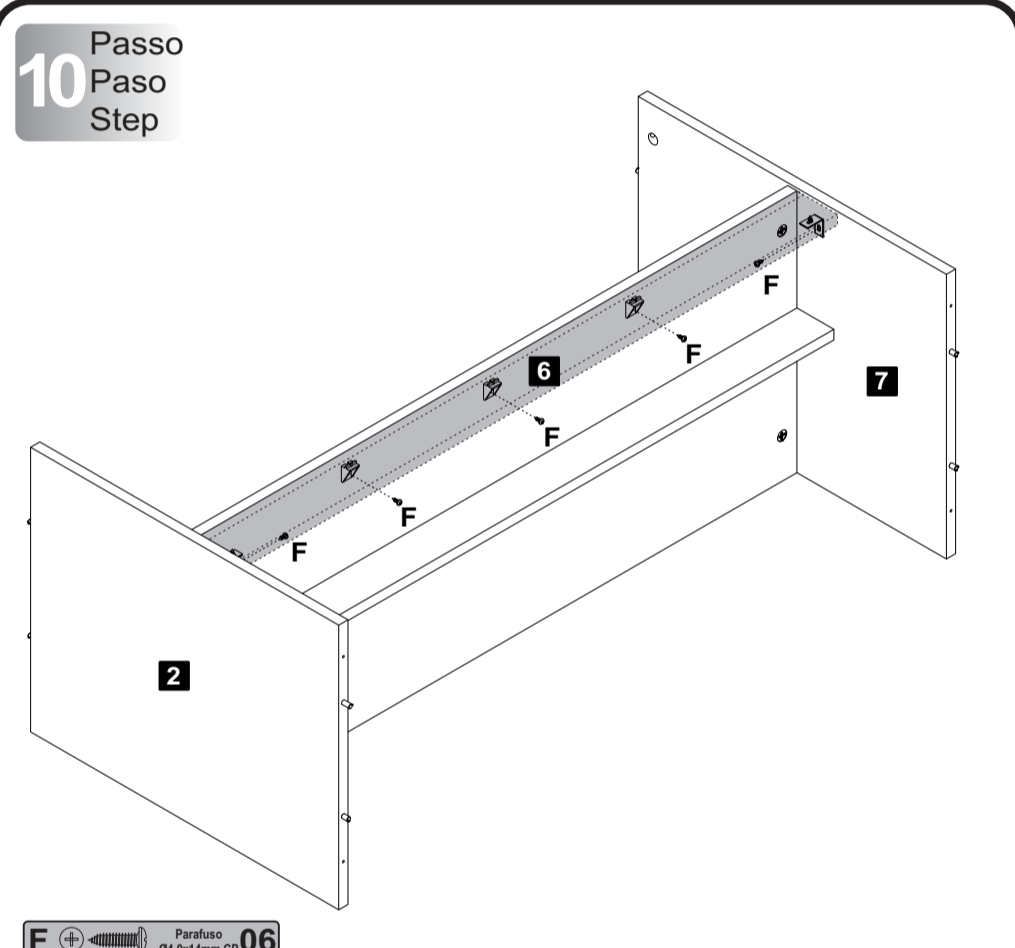

11
Passo
Paso
Step

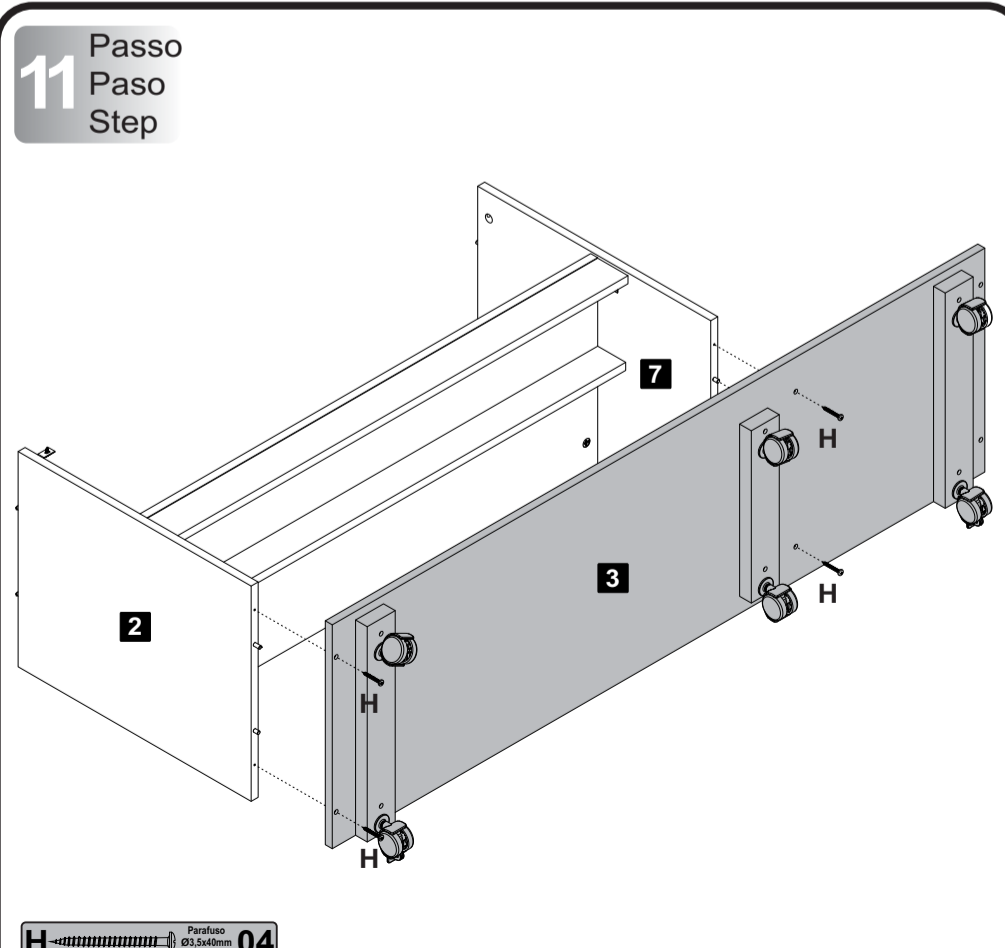

12
Passo
Paso
Step

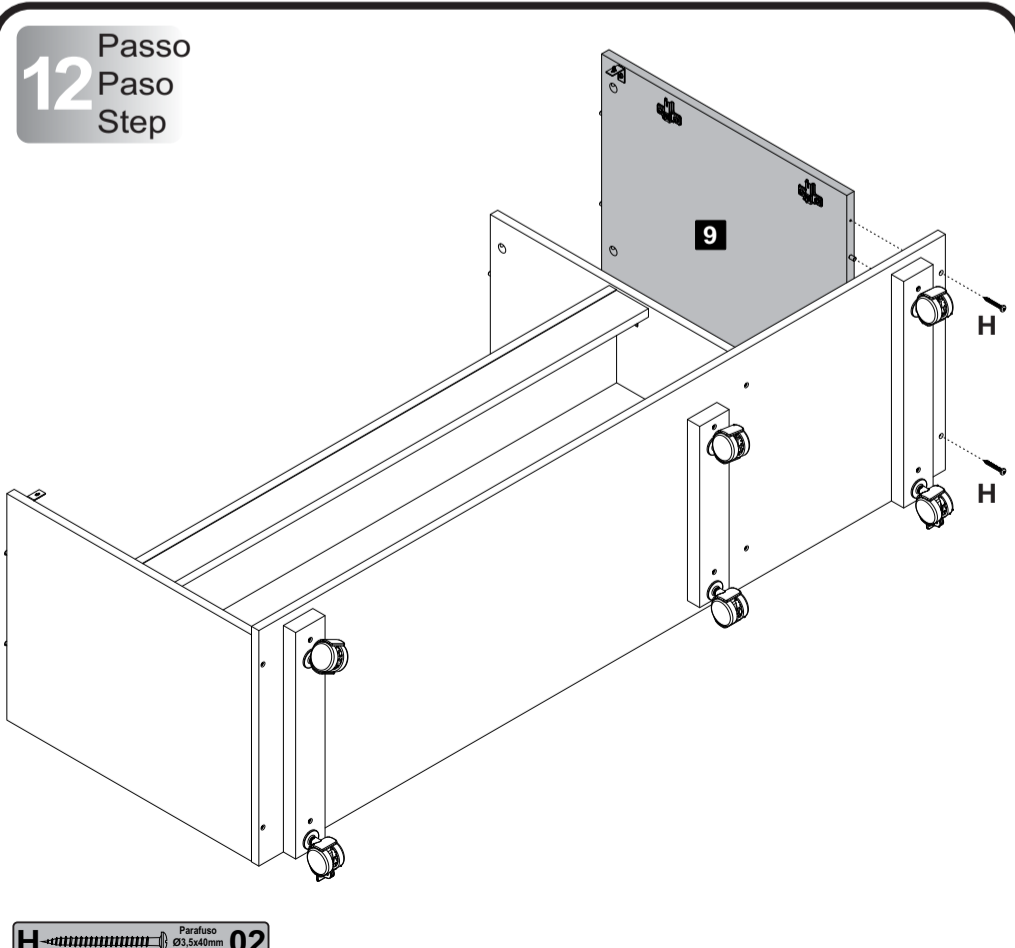

13 Passo
Paso
Step

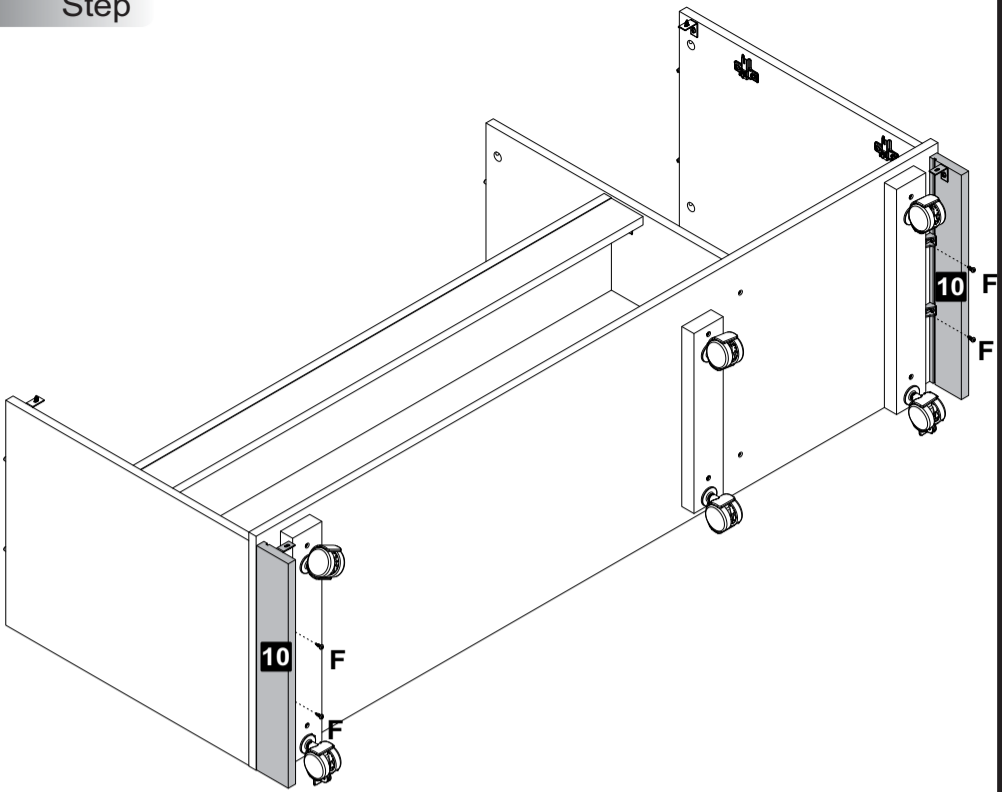

F Parafuso Ø4x14mm CP 04

14 Passo
Paso
Step

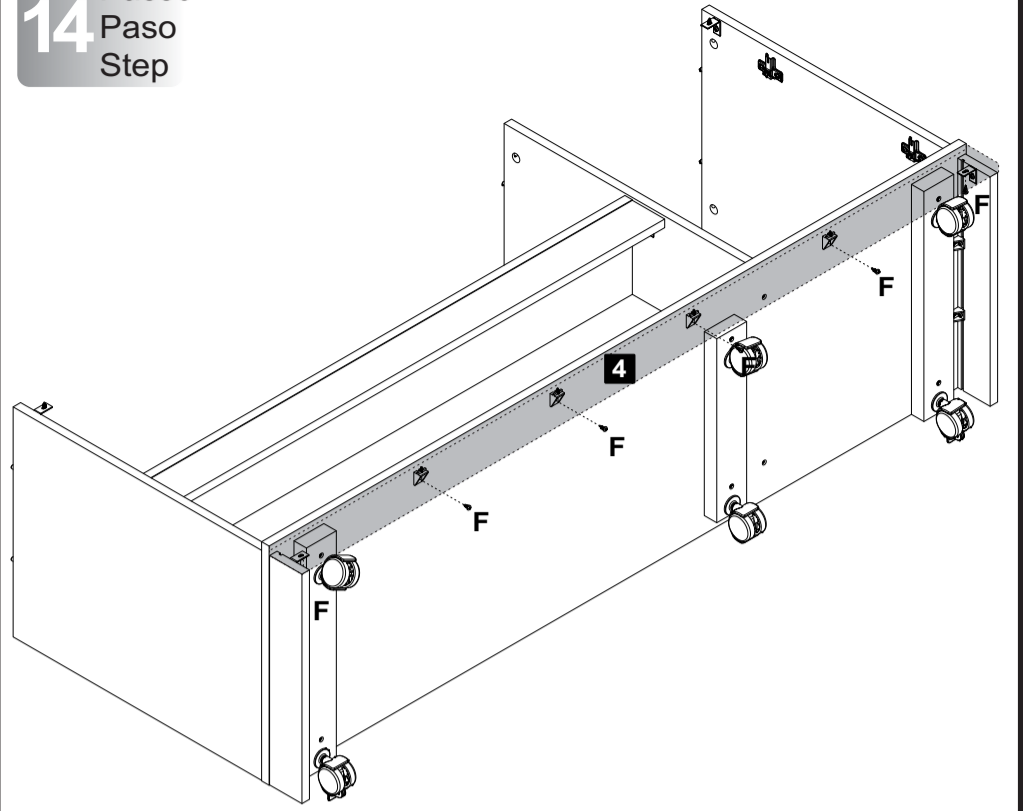

F Parafuso Ø4x14mm CP 06

15 Passo
Paso
Step

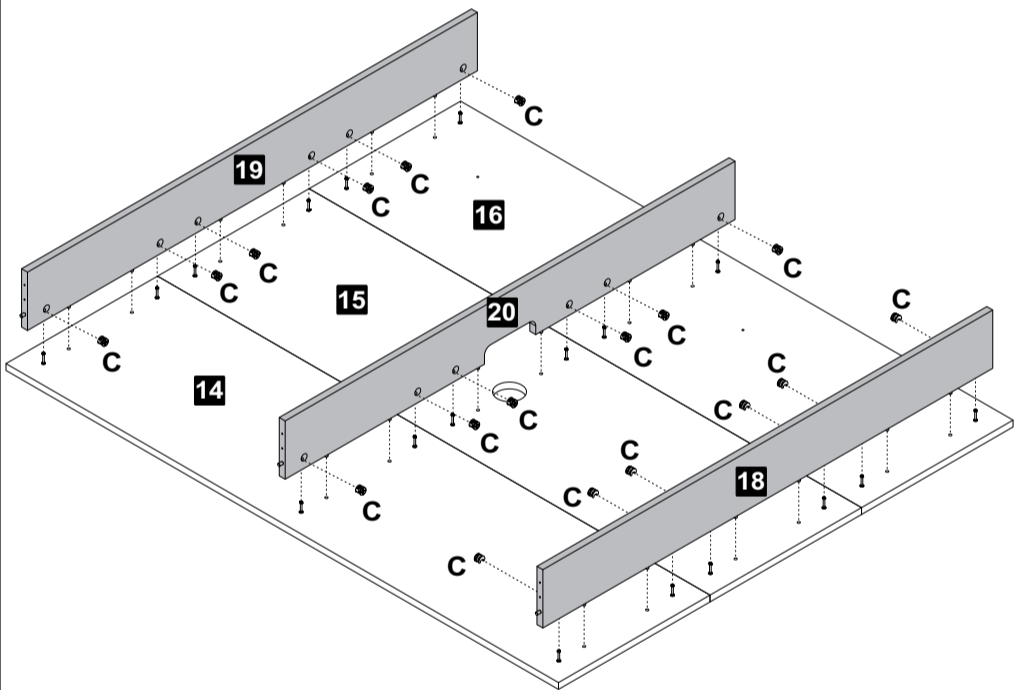

C Tambor 18

16 Passo
Paso
Step

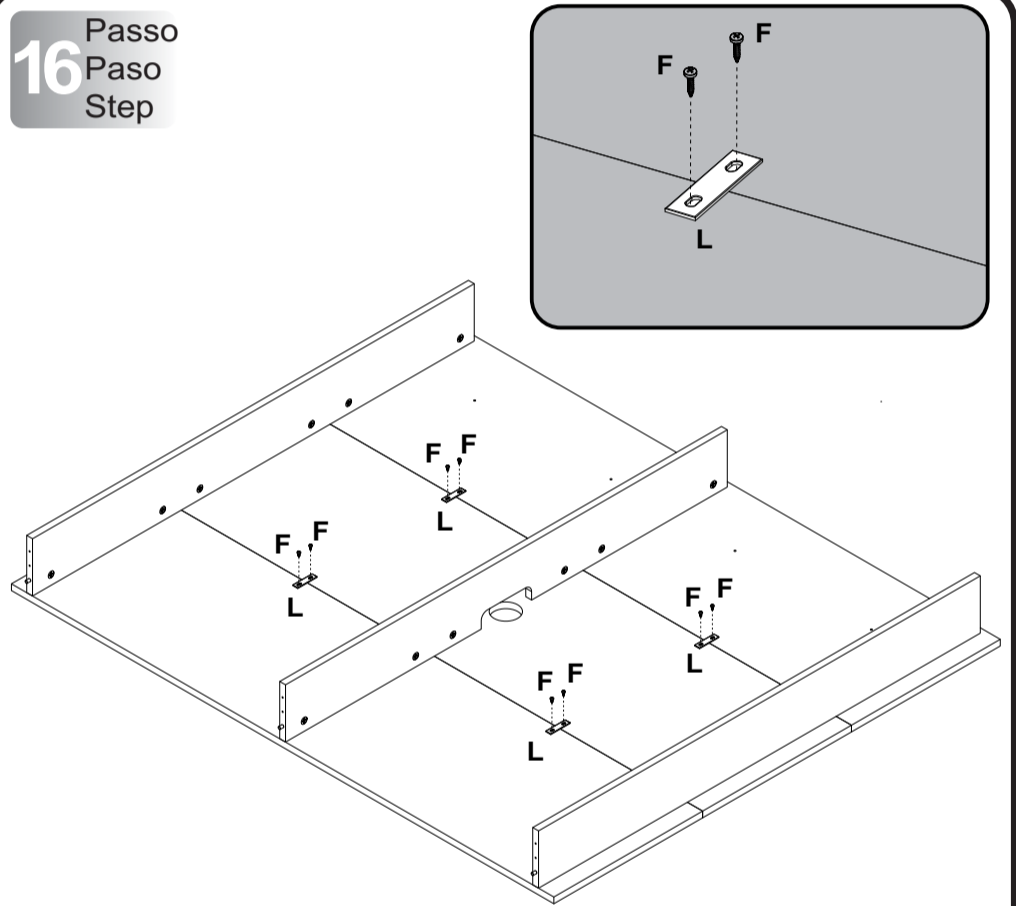

F Parafuso Ø4,0x14mm CP 08 L Chapa reta 50x13mm 04

17 Passo
Paso
Step

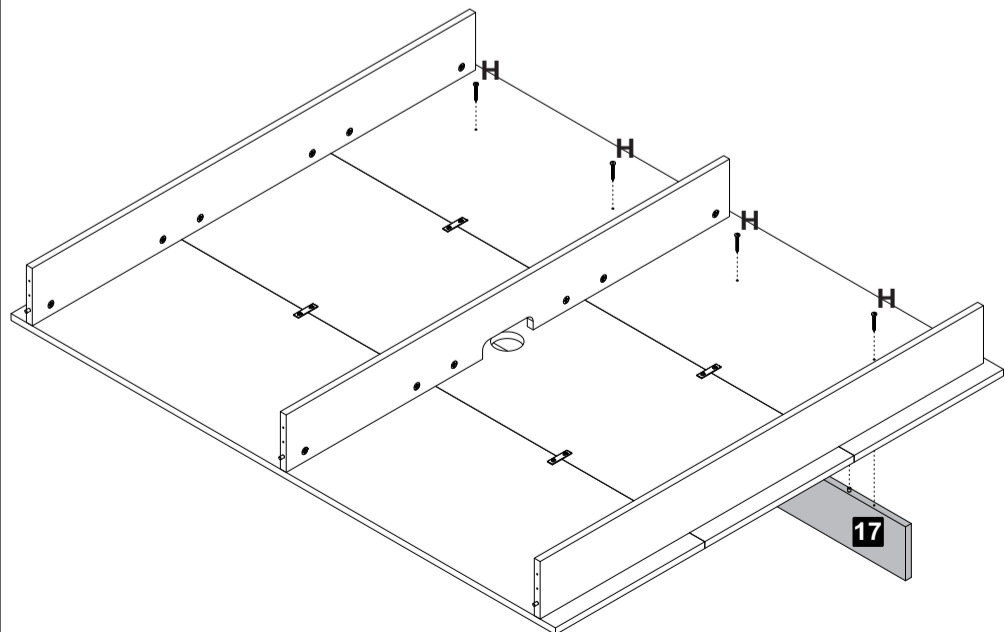

H Parafuso Ø3,5x40mm CP 04

18 Passo
Paso
Step

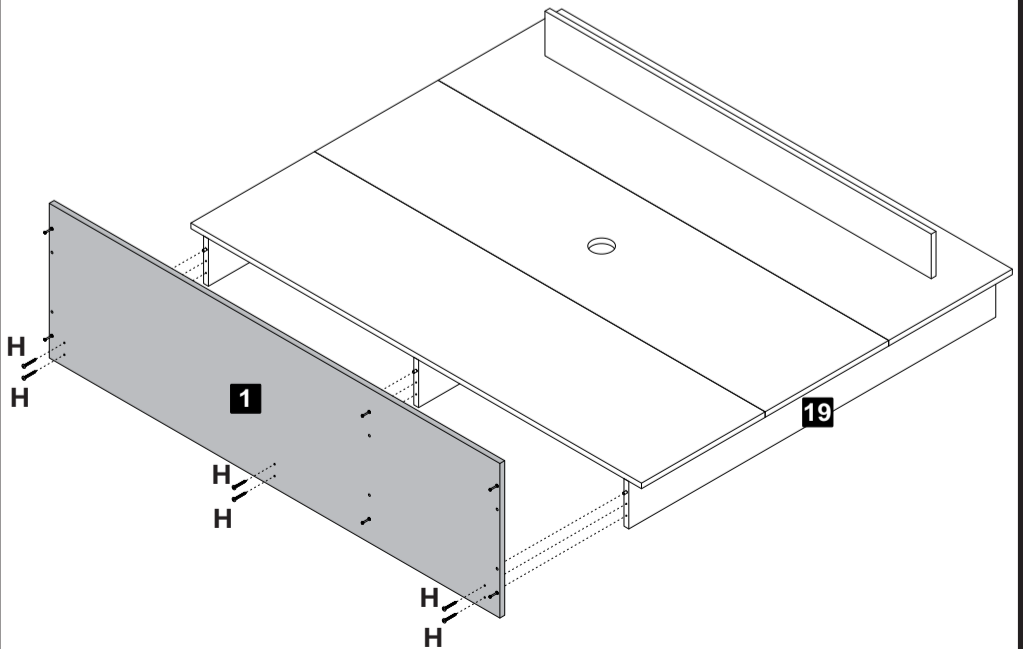

H Parafuso Ø3,5x40mm CP 06

19 Passo
Paso
Step

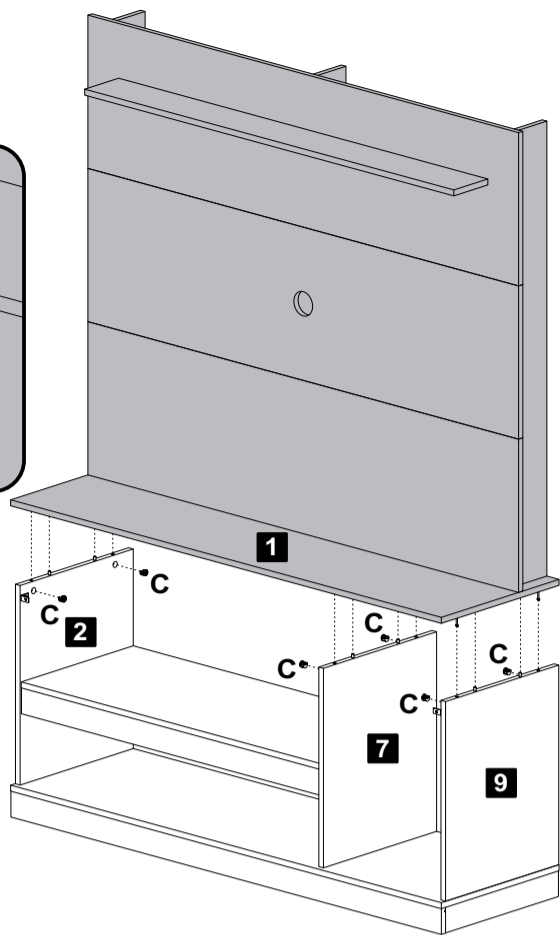
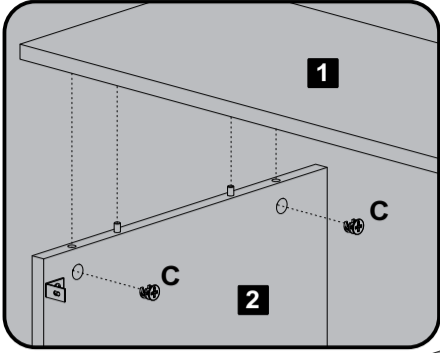

C Tambor 06

20 Passo
Paso
Step

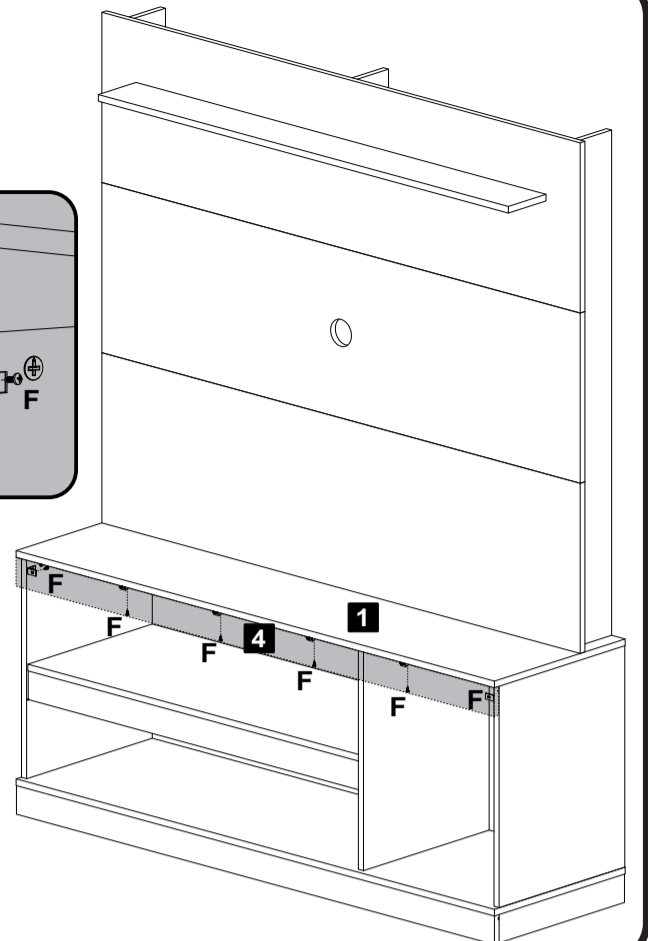
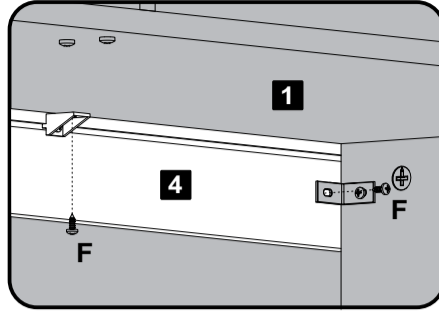

F Parafuso Ø4x14mm CP 06

21 Passo
Paso
Step

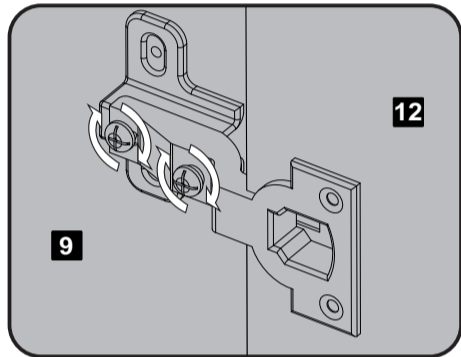
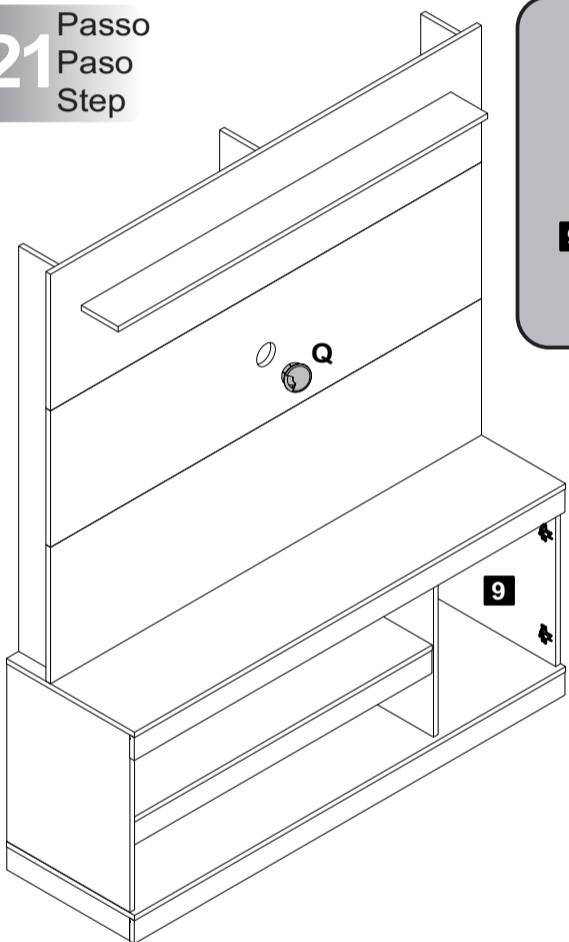

Q Passa Fio Ø60mm 01

22 Passo
Paso
Step

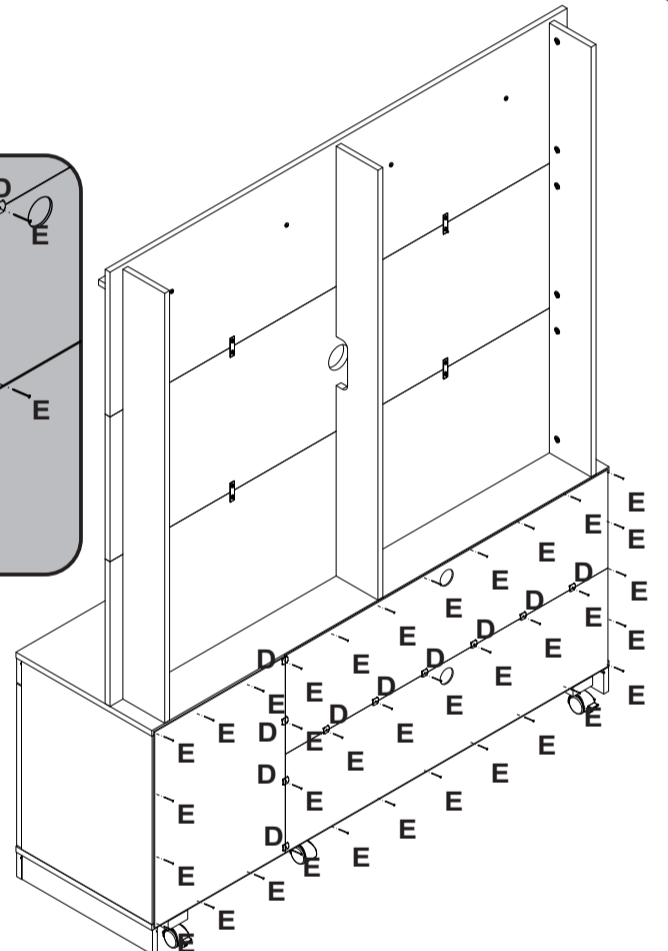
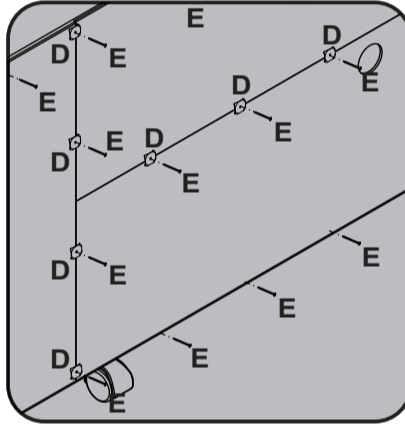

E Tambor 35

23 Passo
Paso
Step

X		kit suporte TV			2
	X1		X2	X3	
	35x77mm	48x28mm	100x56mm		
X6		Parafuso M6 x 16			4
X7		Parafuso M8 x 16			4

24 Passo
Paso
Step

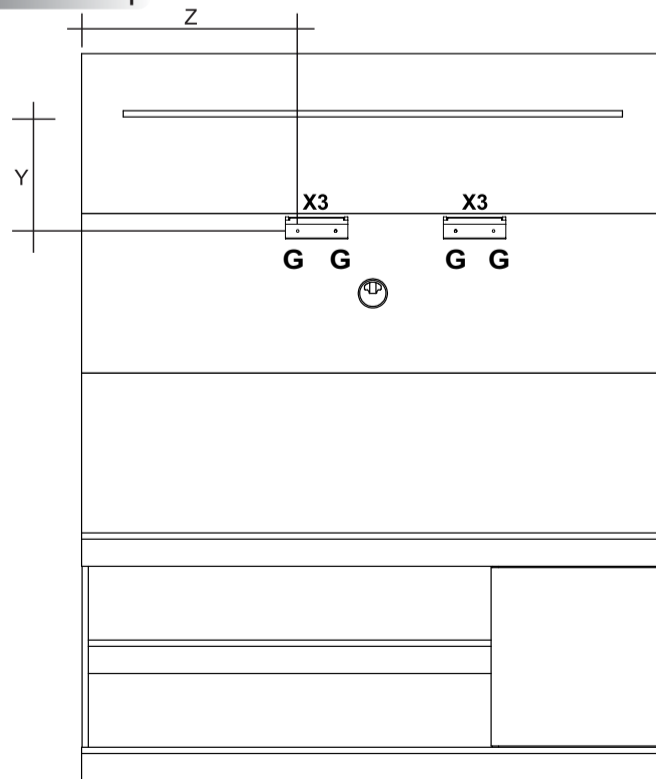

G

Utilizar a Norma VESA do manual da TV, para calcular a centralização e altura da TV no painel.

Usando el manual del estándar VESA TV, centralización y para calcular la altura del panel de TV.

Using the VESA standard TV's manual, centralization and to calculate the height of the TV panel.

G Parafuso Ø4,0x30mm CP 04 X3 Kit Suporte TV 02



-Para facilitar a fixação do Suporte Universal, enviamos 2 modelos de parafusos que estão de acordo com os padrões mais usados pelos principais fabricantes de TVs LCD / LED / PLASMA / 3D do mercado. Caso nenhum dos 2 modelos se encaixe adequadamente ao seu televisor, adquira o parafuso compatível com sua TV em qualquer loja de ferragens. Para evitar danos à sua TV, não aperte demasiadamente os parafusos.

-Para facilitar la colocación del soporte universal, enviamos 2 modelos de tornillos que cumplen con los estándares más utilizados por los principales fabricantes de televisores. Si ninguno de los modelos se ajusta a su televisor correctamente, compre el tornillo compatible con su televisor en cualquier ferretería. Para evitar daños a su televisor, no apriete demasiado los tornillos.

-To make it easier to attach the TV support, we send 2 screw models that match the most commonly used TVs. If neither model fits your TV properly, purchase the compatible screw from any hardware store. To prevent damage to your TV, do not over tighten the screws.

25 Passo
Paso
Step

Suporte Superior

Utilizar o parafuso indicado no manual da TV X6,X7(VESA).
Use el tornillo indicado del televisor manual X6,X7(VESA).
Use the screw indicated the TV's manual X6,X7(VESA).

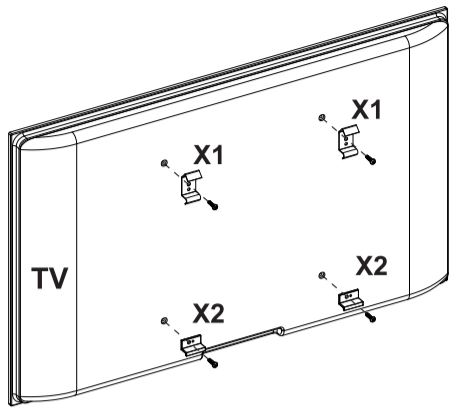
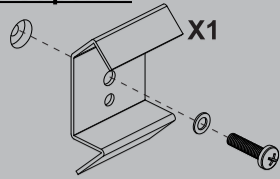

Suporte Inferior

Utilizar o parafuso indicado no manual da TV X6,X7(VESA).
Use el tornillo indicado del televisor manual X6,X7(VESA).
Use the screw indicated the TV's manual X6,X7(VESA).

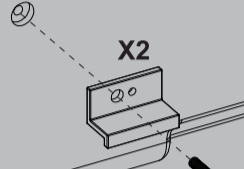

X1 Kit Suporte TV **02**
X2 Kit Suporte TV **02**

26 Passo
Paso
Step

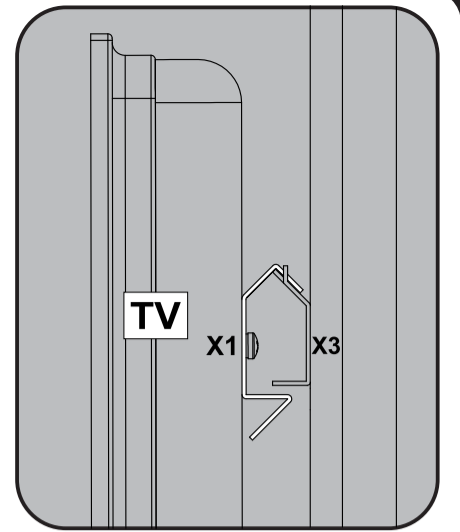
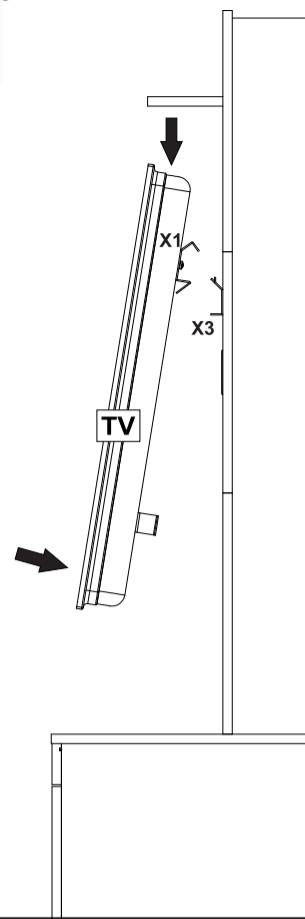

27 Passo
Paso
Step

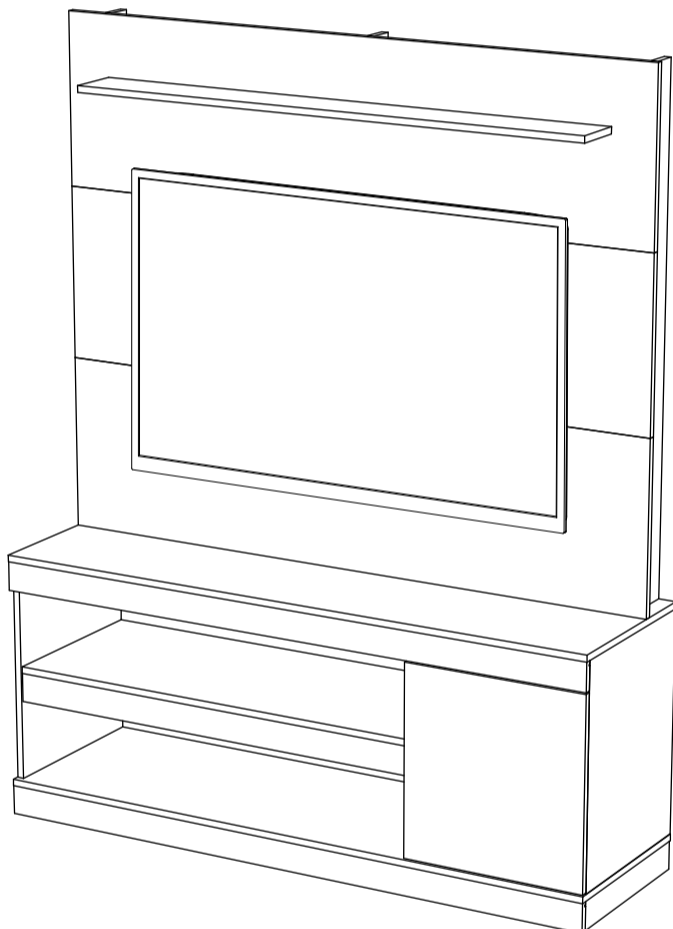

Garantia

Este certificado de Garantia é uma vantagem adicional oferecida ao consumidor, porém para que o mesmo tenha validade é imprescindível que seja apresentada a NOTA FISCAL de compra do produto.

Com este produto, a **Artely** tem como objetivo atender plenamente o proprietário-consumidor, proporcionando a garantia na forma aqui estabelecida, pelo período de três meses a partir da data da nota fiscal de compra. A **Artely** restringe a sua responsabilidade à substituição gratuita das peças defeituosas, em caso de defeitos ou avarias devidamente constatados como sendo de fabricação, durante a vigência desta garantia.

A **Artely** declara a garantia nula e sem efeito se o produto for alterado, adulterado, molhado ou consertado e ainda pela prática de montagem inadequada ou mau uso. Também será considerada nula em casos de força maior, como aqueles causados por agentes da Natureza (chuvas, incêndios, excesso de umidade...) e eventos externos como objetos arrastados sobre a superfície do móvel (ex.: TV, DVD, aparelho de som, objetos decorativos...).

Para exercer seus direitos de comprador é importante que antes de montar seu produto você leia com atenção as instruções de cada passo do manual de montagem que acompanha o móvel.

Caso o produto não esteja em conformidade, entre em contato com a loja onde efetuou a compra ou com o nosso Serviço de Atendimento ao Cliente através do e-mail assistencia@artely.com.br ou pelo fone 41 3381 5000 e faça sua reclamação, apontando os defeitos técnicos observados, que teremos o maior prazer em atendê-lo. Para agilizar o seu atendimento, tenha sempre em mãos o manual de montagem com os respectivos números das peças defeituosas, conforme descritas no manual.



ARTELY MÓVEIS LTDA
ALAMEDA ARPO, 2333
CEP / ZIP CODE: 83010-290
SÃO JOSÉ DOS PINHAIS
CURITIBA - PR - BRASIL
Fone / Fax: 41 3381-5000
Phone Number: 55 41 3381-5000
e-mail: artely@artely.com.br
www.artely.com.br