



Para facilitar a fixação do Suporte Universal, enviamos 2 modelos de parafusos que estão de acordo com os padrões mais usados pelos principais fabricantes de TVs LCD / LED / PLASMA / 3D do mercado. Caso nenhum dos 2 modelos se encaixe adequadamente ao seu televisor, adquira o parafuso compatível com sua TV em qualquer loja de ferragens. Para evitar danos à sua TV, não aperte demasiadamente os parafusos.



Atenção

Retirar a TV do painel sempre que:

- Mover o painel
- Manusear os cabos por trás do painel
- Passar novos cabos

- Se a tomada estiver atrás do painel, cuide para que os cabos não fiquem forçando o painel para a frente.

Passos para retirar a TV do painel:

1



Atenção

A TV não sai para os lados devido às travas de segurança do suporte.

VISTA LATERAL

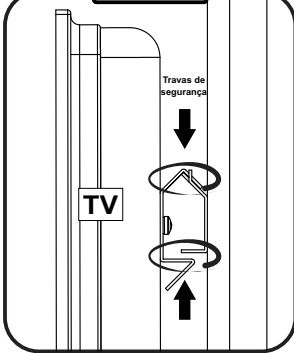

2

Inclinar um pouco a parte de baixo da TV até passar a trava de segurança inferior

VISTA LATERAL

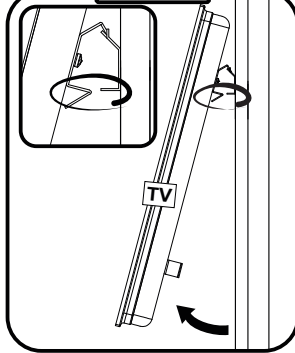

3

Elevar a TV retirando-a totalmente do suporte

VISTA LATERAL

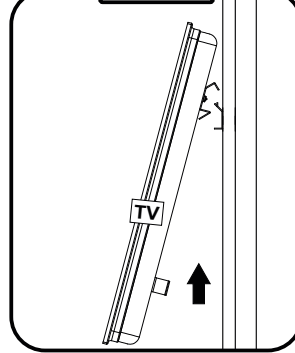

4

Desconectar todos os cabos da TV, retirando-a com segurança

VISTA LATERAL

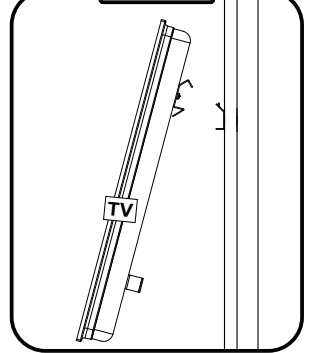

Este painel foi submetido a Testes de Resistência e suporta adequadamente o peso da TV. Não nos responsabilizamos por eventuais danos à TV causados por manuseio inadequado.



-Para una fácil fijación del soporte universal, enviamos 2 de los modelos de tornillos más utilizados en los televisores. Si ninguno encajar en su TV, busque otro en una ferretería. Para evitar daños en su televisor, no apriete demasiado los tornillos.
-To make it easier to attach the TV support, we send 2 screw models that match the most commonly used TVs. If neither model fits your TV properly, purchase the compatible screw from any hardware store. To prevent damage to your TV, do not over tighten the screws.



ATENCIÓN! ATTENTION!

Retire la TV del panel siempre que:

Take out the TV from the panel in the following situations:

- Mover el panel;
- You are moving the wall panel;
- Manejar los cables detrás del panel;
- You are handling the cables;
- Pasar nuevos cables.
- You are passing new cables.

- Si el tomacorriente está detrás del panel, tenga cuidado de que los cables no fuercen el panel adelante.

- If the power plug is behind the panel, be sure that the cables are not forcing the panel forward.

Pasos para retirar la televisión del panel: Steps to remove the TV from the wall panel:

1

-La TV no sale para los lados, debido a las travas de seguridad del soporte;

-There are safety locks in the support that keep the TV in its place. You can not take out the TV moving it to the sides.

VISTA LATERAL
SIDE VIEW

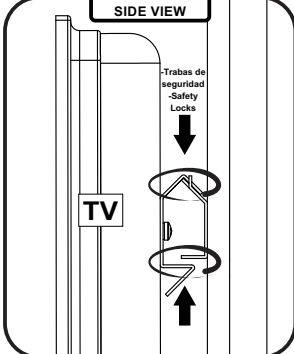

2

-Incline la parte inferior del televisor ligeramente hasta que pase la trava de seguridad inferior;

-Incline the bottom of the TV so that it passes the lower safety lock.

VISTA LATERAL
SIDE VIEW

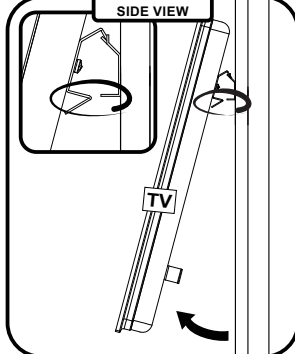

3

-Levante el televisor quitándolo completamente del soporte;

-Lift the TV, removing it completely from the support.

VISTA LATERAL
SIDE VIEW

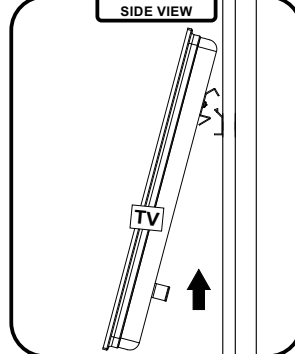

4

-Desconecte todos los cables de la TV, quitándola con seguridad.

-Disconnect all the TV cables and remove the TV safely.

VISTA LATERAL
SIDE VIEW

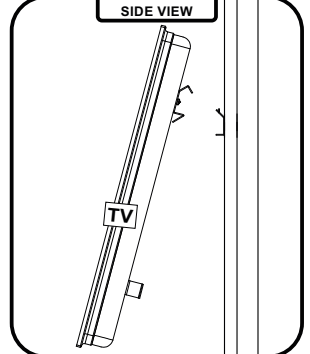

-Ese panel fue sometido a Pruebas de Resistencia y soporta adecuadamente el peso del televisor. No somos responsables de ningún daño al televisor causado por manejo inadecuado.
-This panel has undergone resistance tests and adequately supports the weight of the TV. We are not responsible for TV damage caused by inappropriate handling.

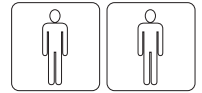

Painel Presence

Panel Precense / Presence Panel

Versão 1.0 / Versión 1.0 / 1.0 Version

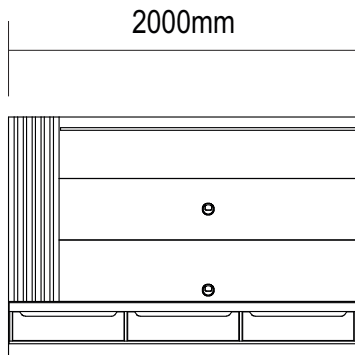

frente/frente/front

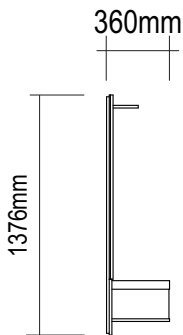

lateral/lado/side

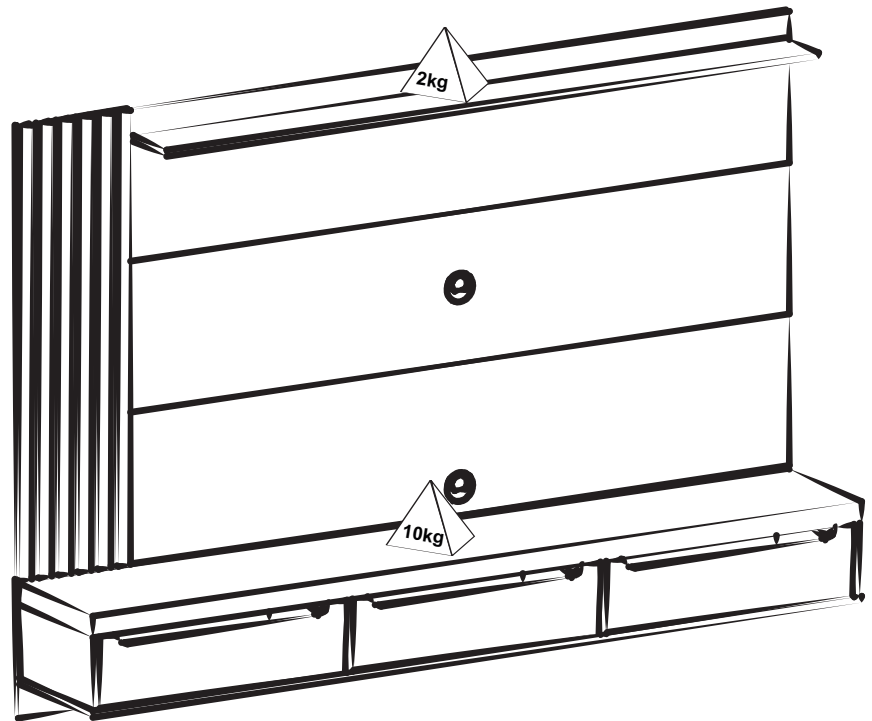

Conservação e Limpeza - Conservación y Limpieza - Conservation and Cleaning

Não expor o produto ao sol, altas temperaturas e umidade. Não arrastar objetos sobre a superfície do móvel (ex.: TV, DVD, aparelho de som, objetos decorativos...) e manter em local seco e arejado. Para a limpeza, utilizar um pano seco e macio. Não é necessário o uso de materiais abrasivos ou álcool.

No exponga el producto a la luz solar, las altas temperaturas y la humedad. No arrastre los objetos a través de la superficie de la unidad (por ejemplo, TV, DVD, equipo de música, objetos de decoración ...) Mantener en un lugar fresco y seco. Para la limpieza, utilizar un paño seco y suave. El uso de materiales abrasivos o del alcohol no es necesario.

Do not expose the product to sunlight, high temperatures and humidity. Do not drag objects across the surface of the unit (TV, DVD, stereo, decorative objects ...) keep it in a cool dry place. For cleaning, use a dry and soft cloth. Do not use abrasive materials or alcohol.

Garantia

Este certificado de Garantia é uma vantagem adicional oferecida ao consumidor, porém para que o mesmo tenha validade é imprescindível que seja apresentada a NOTA FISCAL de compra do produto.

Com este produto, a **Artely** tem como objetivo atender plenamente o proprietário-consumidor, proporcionando a garantia na forma aqui estabelecida, pelo período de três meses a partir da data da nota fiscal de compra. A **Artely** restringe a sua responsabilidade à substituição gratuita das peças defeituosas, em caso de defeitos ou avarias devidamente constatados como sendo de fabricação, durante a vigência desta garantia.

A **Artely** declara a garantia nula e sem efeito se o produto for alterado, adulterado, molhado ou consertado e ainda pela prática de montagem inadequada ou mau uso. Também será considerada nula em casos de força maior, como aqueles causados por agentes da Natureza (chuvas, incêndios, excesso de umidade, cupins,...) e eventos externos como objetos arrastados sobre a superfície do móvel (ex.: TV, DVD, aparelho de som, objetos decorativos...).

Para exercer seus direitos de comprador é importante que antes de montar seu produto você leia com atenção as instruções de cada passo do manual de montagem que acompanha o móvel.

Caso o produto não esteja em conformidade, entre em contato com a loja onde efetuou a compra ou com o nosso Serviço de Atendimento ao Cliente através do e-mail assistencia@artely.com.br ou pelo fone 41 3381 5000 e faça sua reclamação, apontando os defeitos técnicos observados, que teremos o maior prazer em atendê-lo. Para agilizar o seu atendimento, tenha sempre em mãos o manual de montagem com os respectivos números das peças defeituosas, conforme descritas no manual.





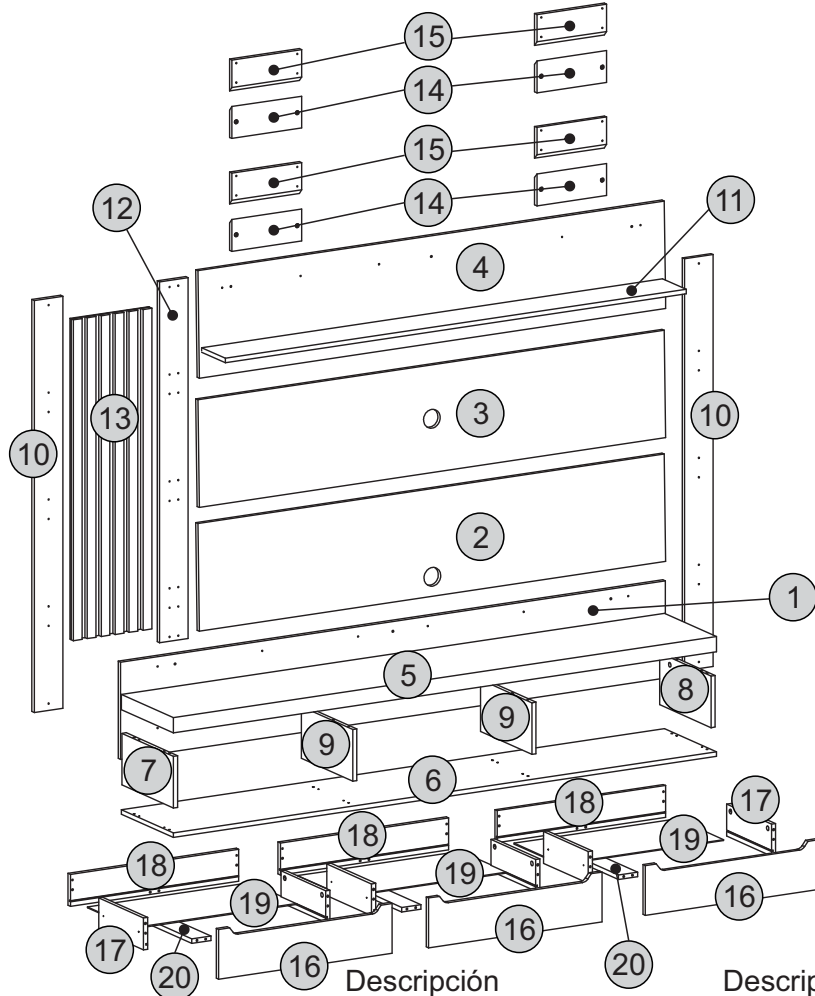
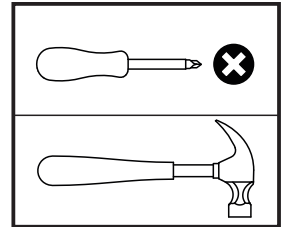



- O número na borda da peça corresponde ao manual.
- Para retirada do número usar Lustra-Móveis, Alcool em Gel ou Borracha.
- El número en el borde de la pieza coincide con el manual.
- Use una goma de borrar blanca, alcohol en gel o lustrador para muebles para eliminar los números.
- The number on the edge of the piece matches the manual.
- Use a White eraser, Alcohol Gel or Furniture Polish to remove the numbers.

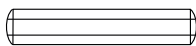

Descrição	Descripción	Description	Qty
1-Painel nicho (2000x320x15mm)	1-Panel nicho	1-Nicho panel	1
2-Painel inferior (1712x352x15mm)	2-Panel abajo	2-Bottom panel	1
3-Painel central (1712x352x15mm)	3-Panel central	3-Center panel	1
4-Painel superior (1712x352x15mm)	4-Panel superior	4-Upper panel	1
5-Tampo (1994x330x50mm)	5-Tapa	5-Top	1
6-Base (1994x330x15mm)	6-Base	6-Base	1
7-Lateral esquerda (170x327x15mm)	7-Lado izquierda	7-Left side	1
8-Lateral direita (170x327x15mm)	8-Lado derecha	8-Right side	1
9-Divisão (170x327x15mm)	9-División	9-Division	2
10-Travessa maior (1356x105x15mm)	10-Travesaño maior	10-Big crosspiece	2
11-Prateleira (1692x150x15mm)	11-Anaque	11-Shelf	1
12-Travessa suporte (1188x105x15mm)	12-Travesaño Soporte	12-Crosspiece support	1
13-Painel lateral (1056x288x15mm)	13-Panel lado	13-Side panel	1
14-Travessa parede (256x105x15mm)	14-Travesaño pared	14-Wall crosspiece	4
15-Travessa menor (256x105x15mm)	15-Travesaño menor	15-Small crosspiece	4
16-Frente gaveta (637x164x15mm)	16-Frente cajón	16-Drawer front	3
17-Lateral gaveta (285x105x15mm)	17-Lado cajón	17-Right side	6
18-Traseira gaveta (618x105x15mm)	18-Traseira cajón	18-Drawe back	3
19-Fundo gaveta (598x295x3mm)	19-Fondo cajón	19-Drawer bottom	3
20-Travessa gaveta (285x70x15mm)	20-Travesaño cajón	20-Drawer crosspiece	3

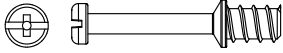
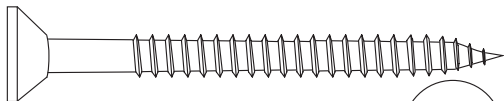
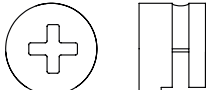
Lista de Materiais

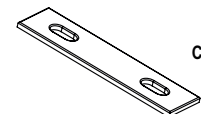
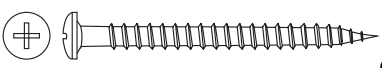
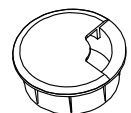
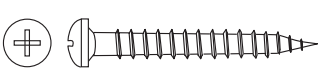
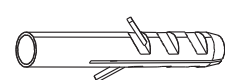
Lista de Materiales/ Hardware List

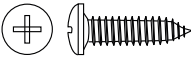
A		Cavilha / Tarugo / Dowel Ø6x30mm Madeira	49	I		Parafuso Ø3,5x12mm CC Metal - Cabeça Philips	24
B		Minifix / Minifix / Minifix Ø7x30mm Metal	18	J		Parafuso / Tornillo / Screw Ø5,5x65mm Cab 13	08
C		Tambor / Tambor / Minifix Cam Ø15x12mm Metal	18	K		Corrediça Telescópica Guia Telescópica / Telescopic Slider 300mm	03
D		Tapa furo adesivo / Adesivo / Hole Cover Ø18mm Papel	16	L		Chapa Reta / Placa Recta / Mending Plate 50x13mm	07
E		Parafuso / Tornillo / Screw / Ø3,5x40mm CP	26	M		Passa Fio / Pasacables / Cable Hole Cover Ø60mm	02
F		Parafuso Tornillo Screw Ø4x30mm CP	04	N		Bucha / Casquillo / Bushing	08
G		Parafuso / Tornillo / Screw Ø4,0x20mm CP	48				
H		Parafuso Ø4x14mm CP Metal - Cabeça Philips	14				

DICAS PARA FIXAR MINIFIX

TIP TO FASTEN THE MINIFIX
PISTA PARA ARREGLAR EL MINIFIX

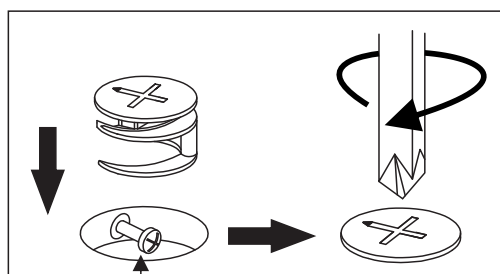

Cabeça do parafuso precisa estar no centro

La cabeza del tornillo debe estar en el centro

Screw head has to be in the center

Parafuso Minifix

Tornillo minifix/Minifix screw

Fixe o parafuso até o ressalto encostar na superfície da peça (veja o exemplo abaixo).

Tighten the screw until its overhang part lean on the piece surface (see the example below).

Fije el tornillo hasta que su parte sobressaliente toque la superficie de la pieza (vea el ejemplo abajo).

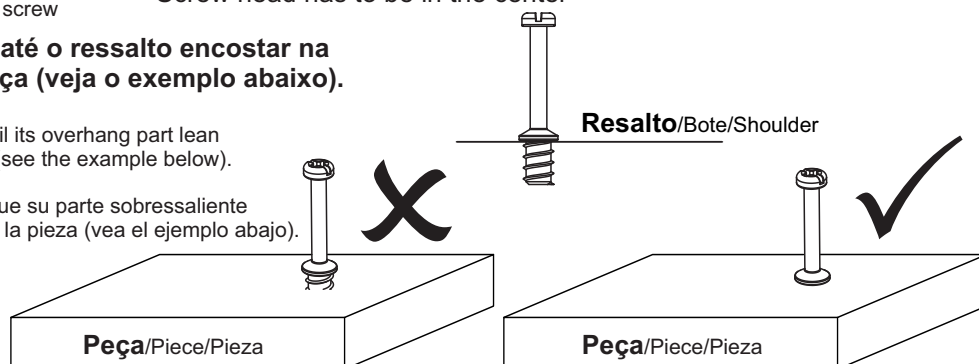

Passo 1

Paso/Step

PEÇA

Pieza/Piece

5 - TAMPO x1

6 - BASE x1

11 - TAMPO x1

FERRAGEM

Herraje/Hardware

A  09

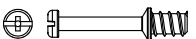
B  06

FERRAMENTA

Herramienta/Tool

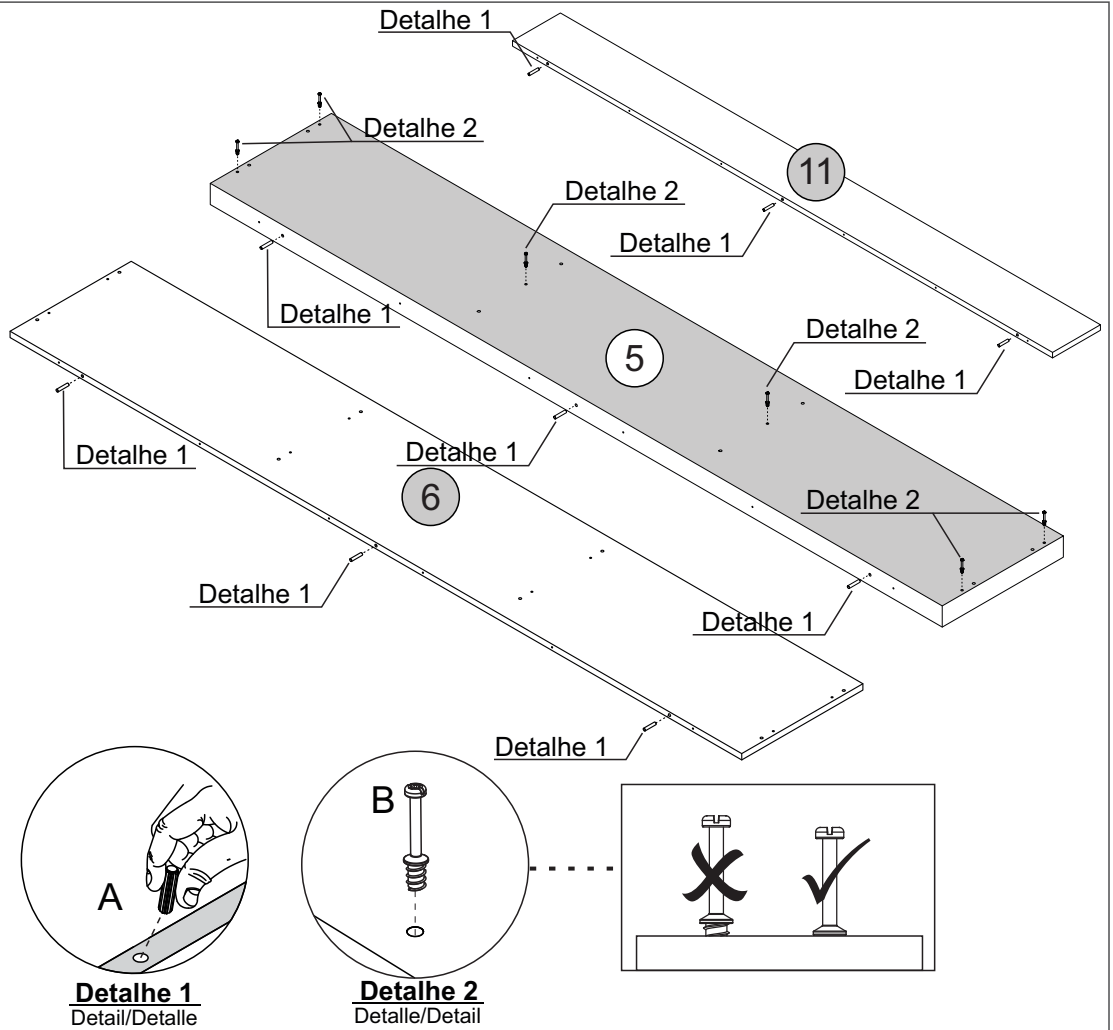
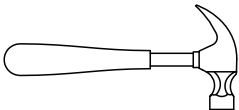
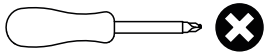

Passo 2

Paso/Step

PEÇA

Pieza/Piece

7 - LATERAL ESQUERDA x1

8 - LATERAL DIREITA x1

FERRAGEM

Herraje/Hardware

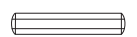
A  08

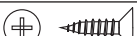
I  04

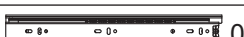
K  02

FERRAMENTA

Herramienta/Tool

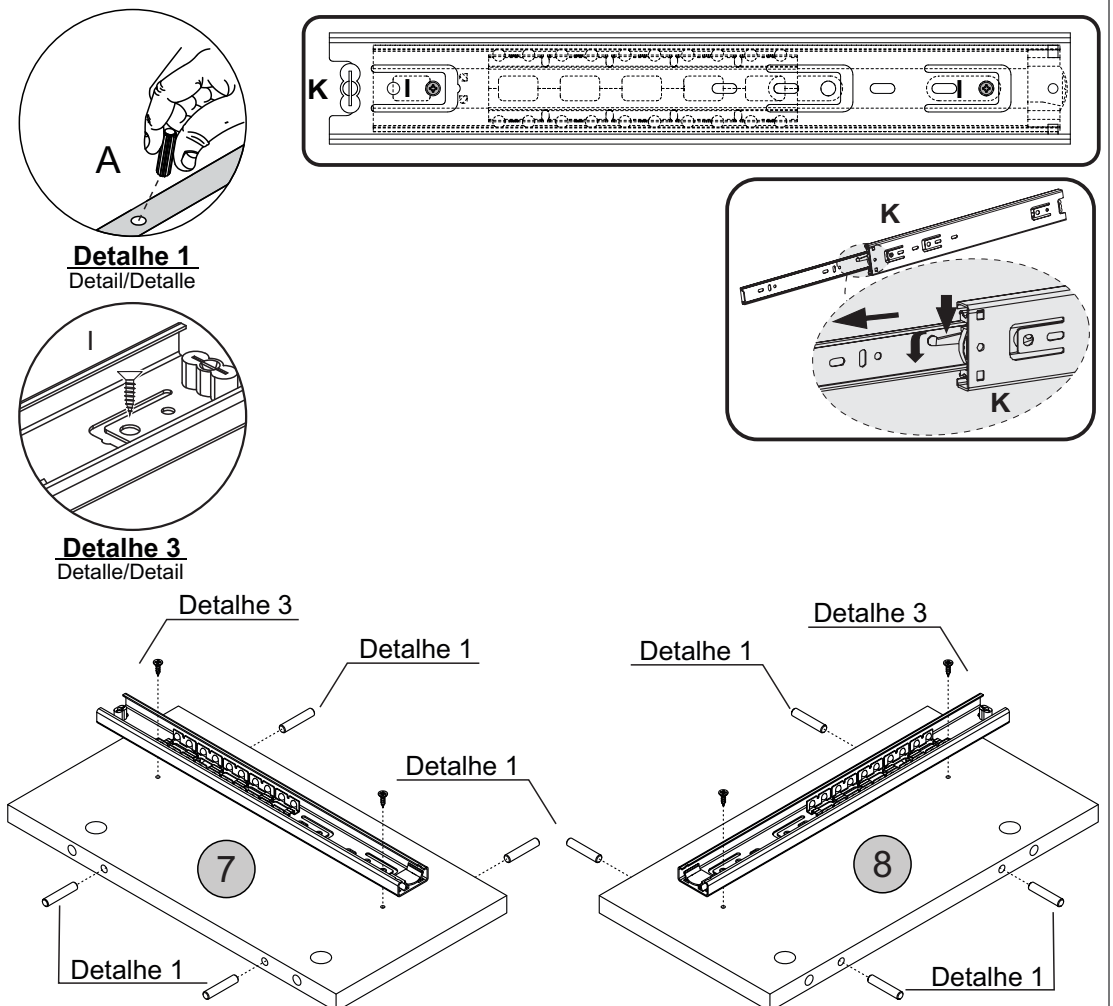
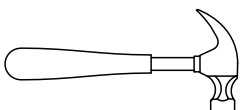
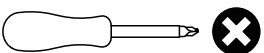

Passo 3

Paso/Step

PEÇA
Pieza/Piece

9 - DIVISÃO x2

FERRAGEM
Herraje/Hardware

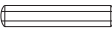
A  08

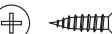
I  04

K  02

FERRAMENTA
Herramienta/Tool

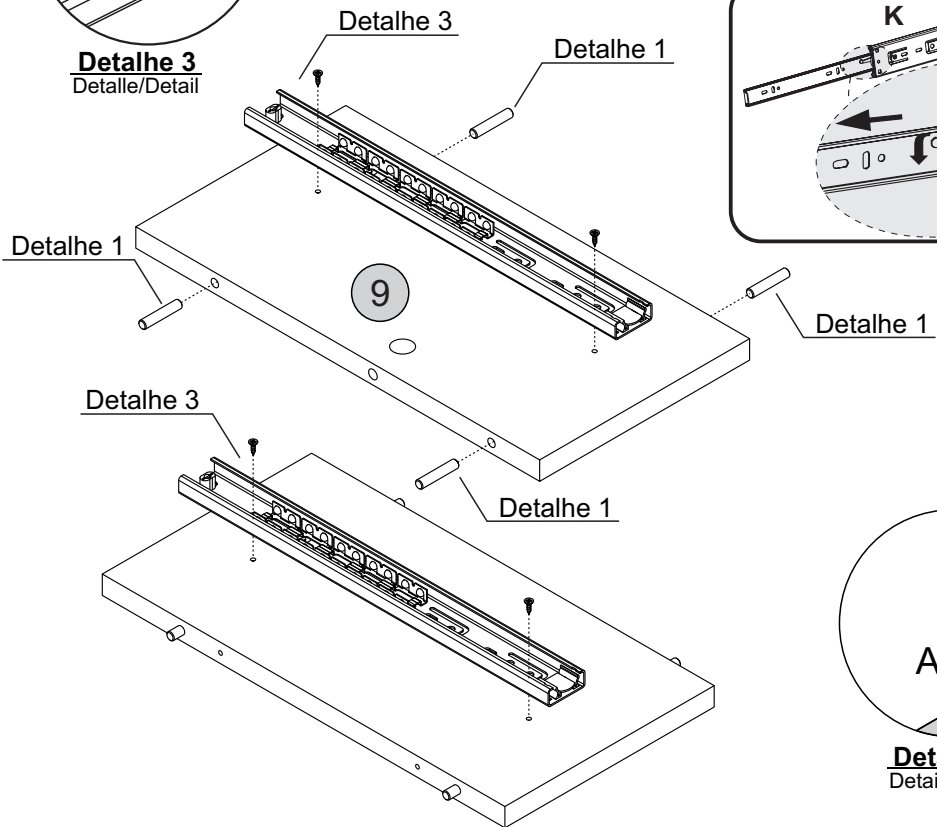
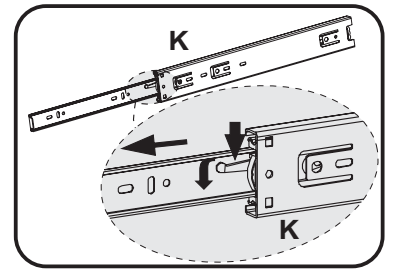
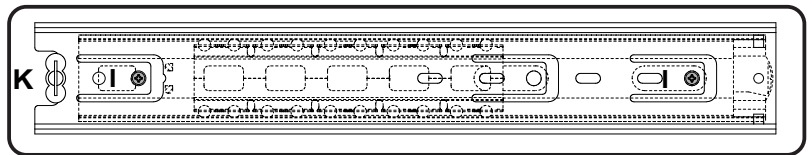
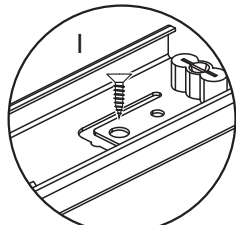
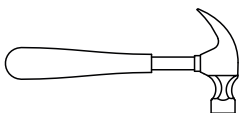
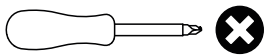

Passo 4

Paso/Step

PEÇA
Pieza/Piece

5 - TAMPO x1

7 - LATERAL ESQUERDA x1

8 - LATERAL DIREITA x1

9 - DIVISÃO x2

FERRAGEM
Herraje/Hardware

C  06

D  06

FERRAMENTA
Herramienta/Tool

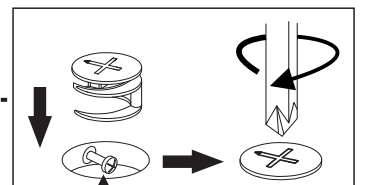
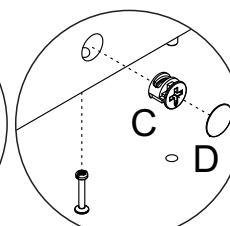
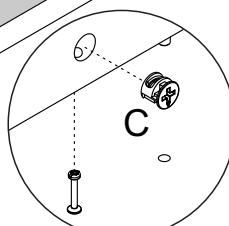
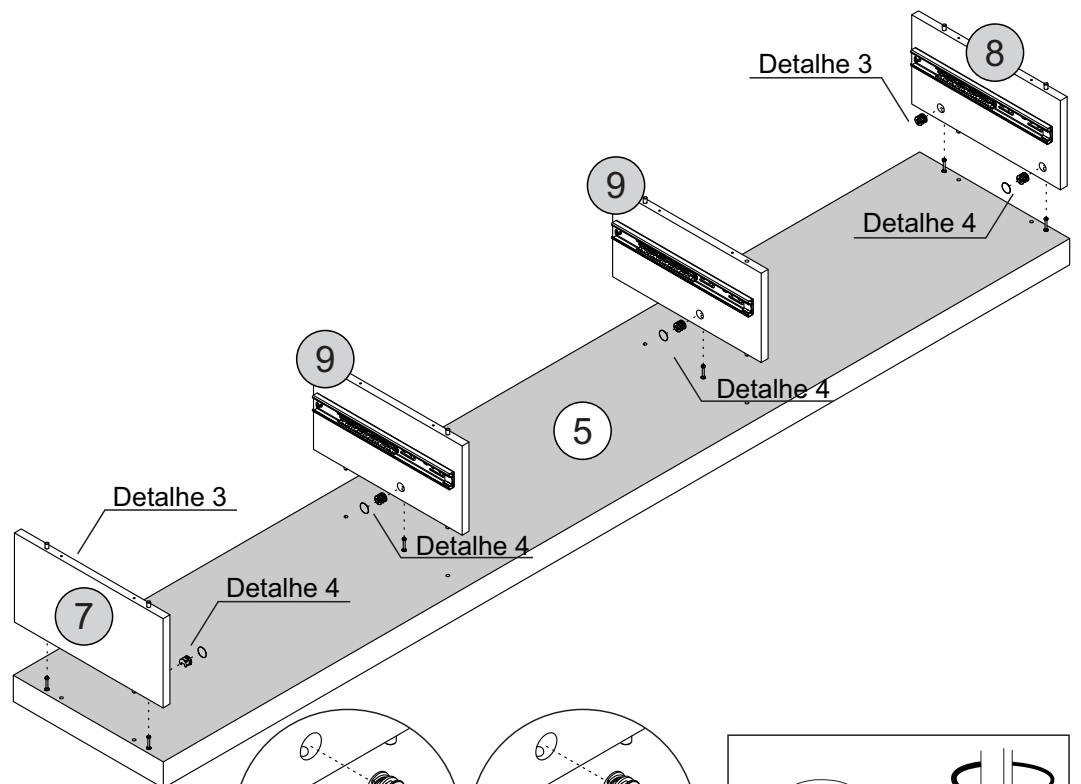
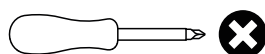

Detalhe 3
Detalle/Detail

Detalhe 4
Detalle/Detail

Cabeça do parafuso precisa estar no centro
La cabeza del tornillo debe estar en el centro
Screw head has to be in the center

Passo 5

Paso/Step

PEÇA
Pieza/Piece

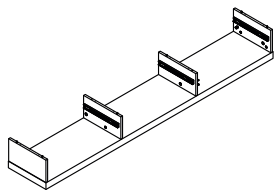

6 - BASE x1

FERRAGEM
Herraje/Hardware



FERRAMENTA
Herramienta/Tool

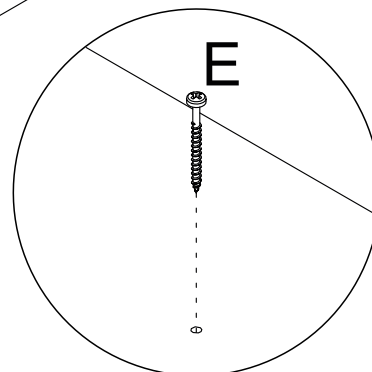
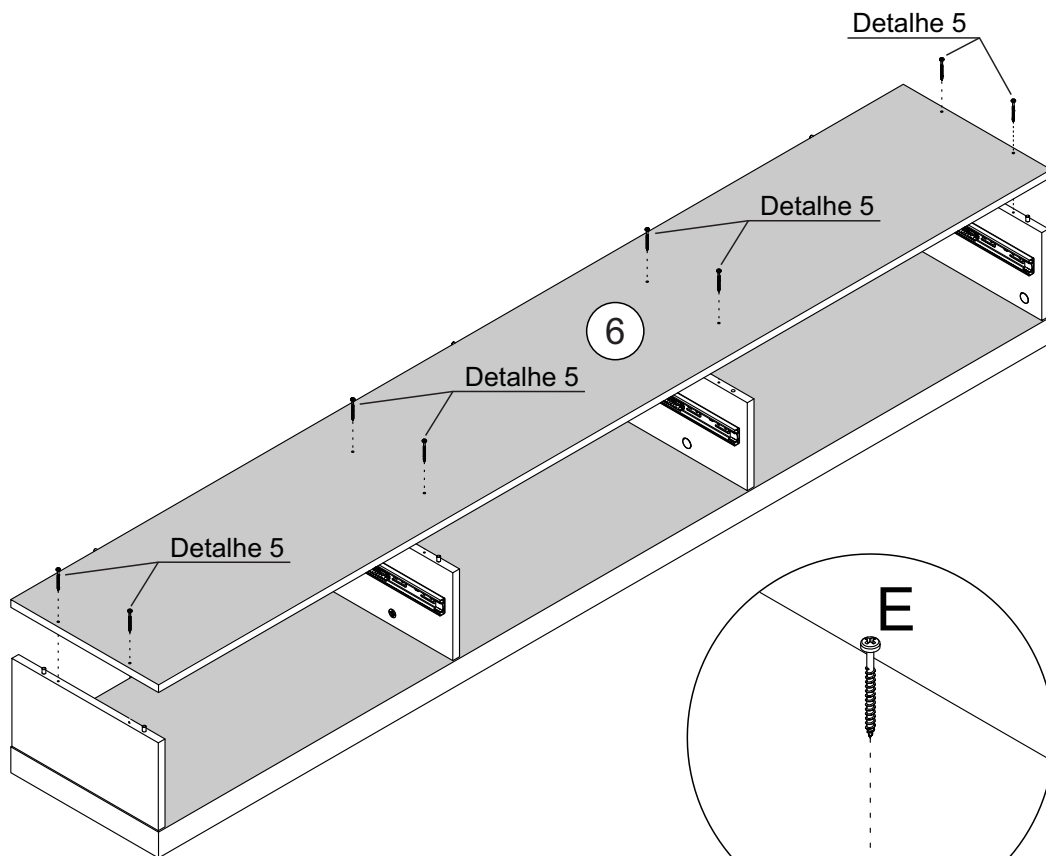
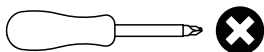

Detalhe 5
Detail/Detalle

Passo 6

Paso/Step

PEÇA
Pieza/Piece

1 - PAINEL NICHU x1

FERRAGEM
Herraje/Hardware



FERRAMENTA
Herramienta/Tool

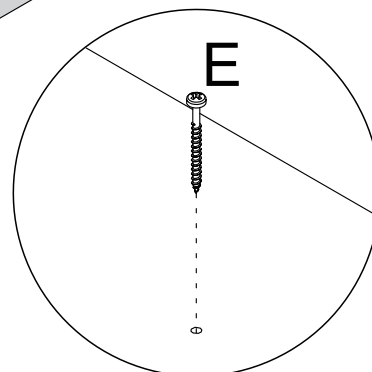
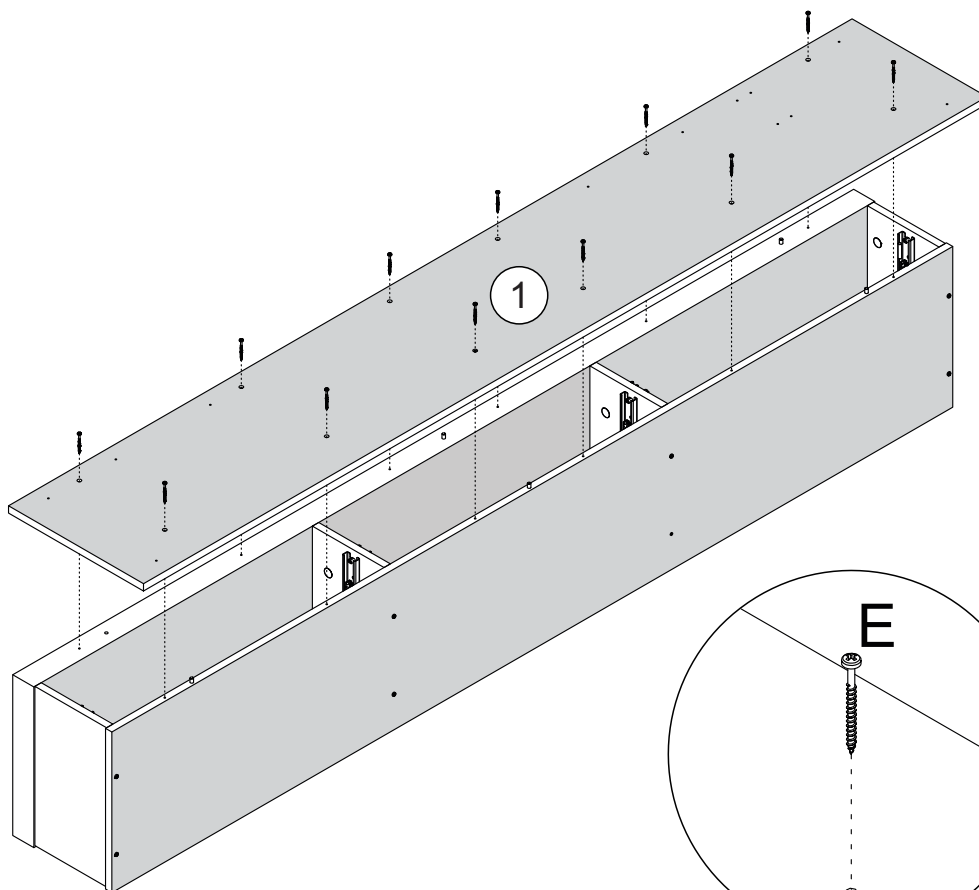
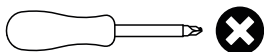

Detalhe 5
Detail/Detalle

Passo 7

Paso/Step

PEÇA
Pieza/Piece

10 - TRAVESSA MAIOR x2

12 - TRAVESSA SUPORTE x1

15 - TRAVESSA MENOR x1

FERRAGEM
Herraje/Hardware

G  12

FERRAMENTA
Herramienta/Tool

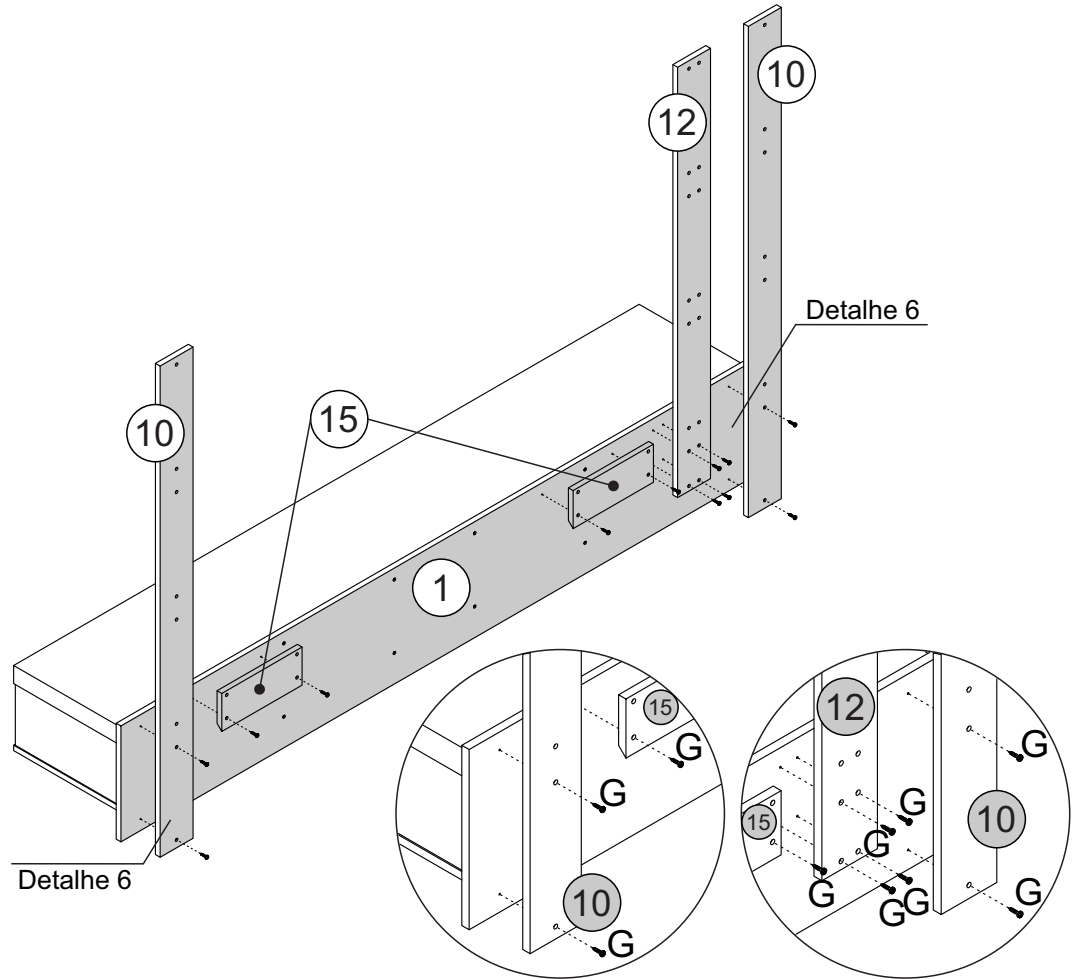
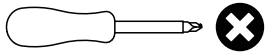

Detalhe 6
Detalle/Detail

Passo 8

Paso/Step

PEÇA
Pieza/Piece

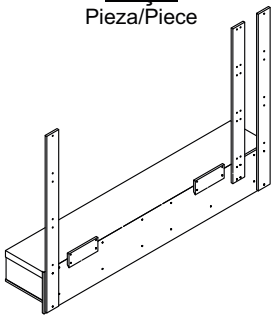

2 - PAINEL INFERIOR x1

FERRAGEM
Herraje/Hardware

G  08

H  04

L  02

FERRAMENTA
Herramienta/Tool

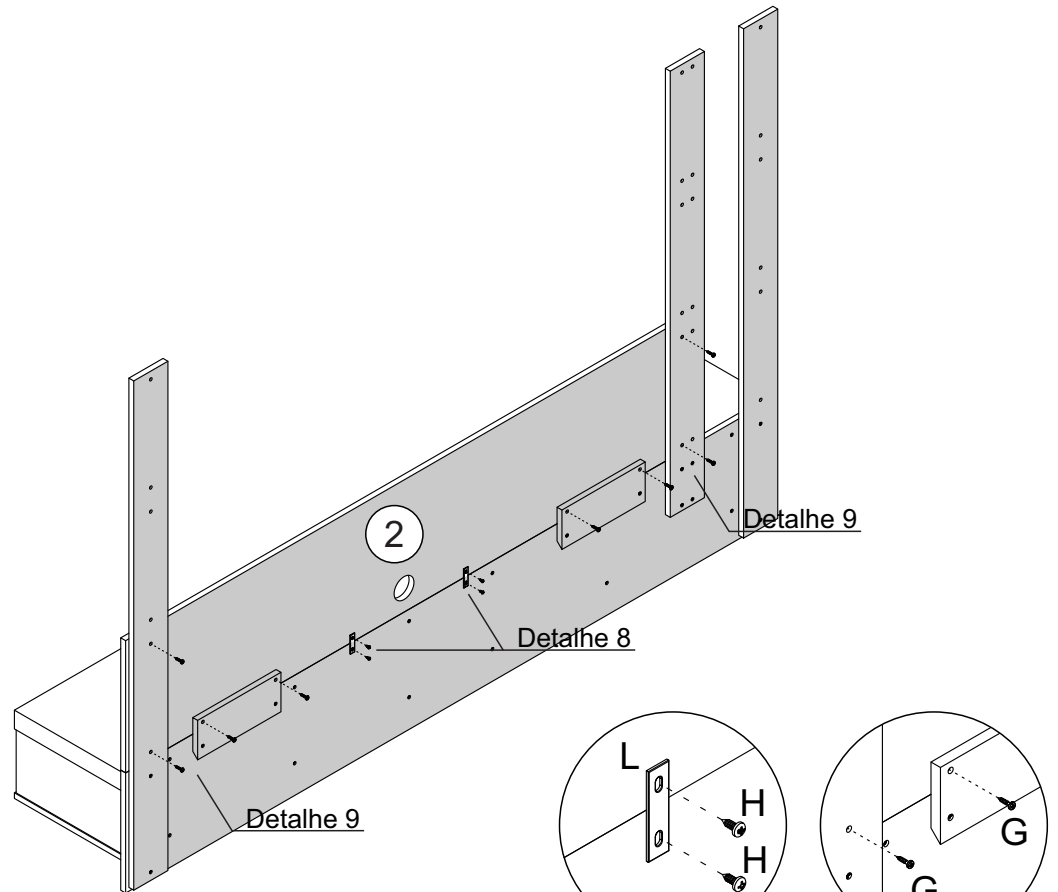
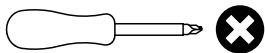

Detalhe 8
Detail/Detalle

Detalhe 9
Detail/Detalle

Passo 9

Paso/Step

PEÇA
Pieza/Piece

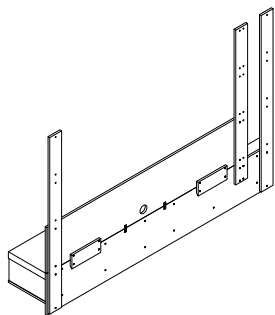

13 - PAINEL LATERAL x1

FERRAGEM
Herraje/Hardware

G  12

FERRAMENTA
Herramienta/Tool

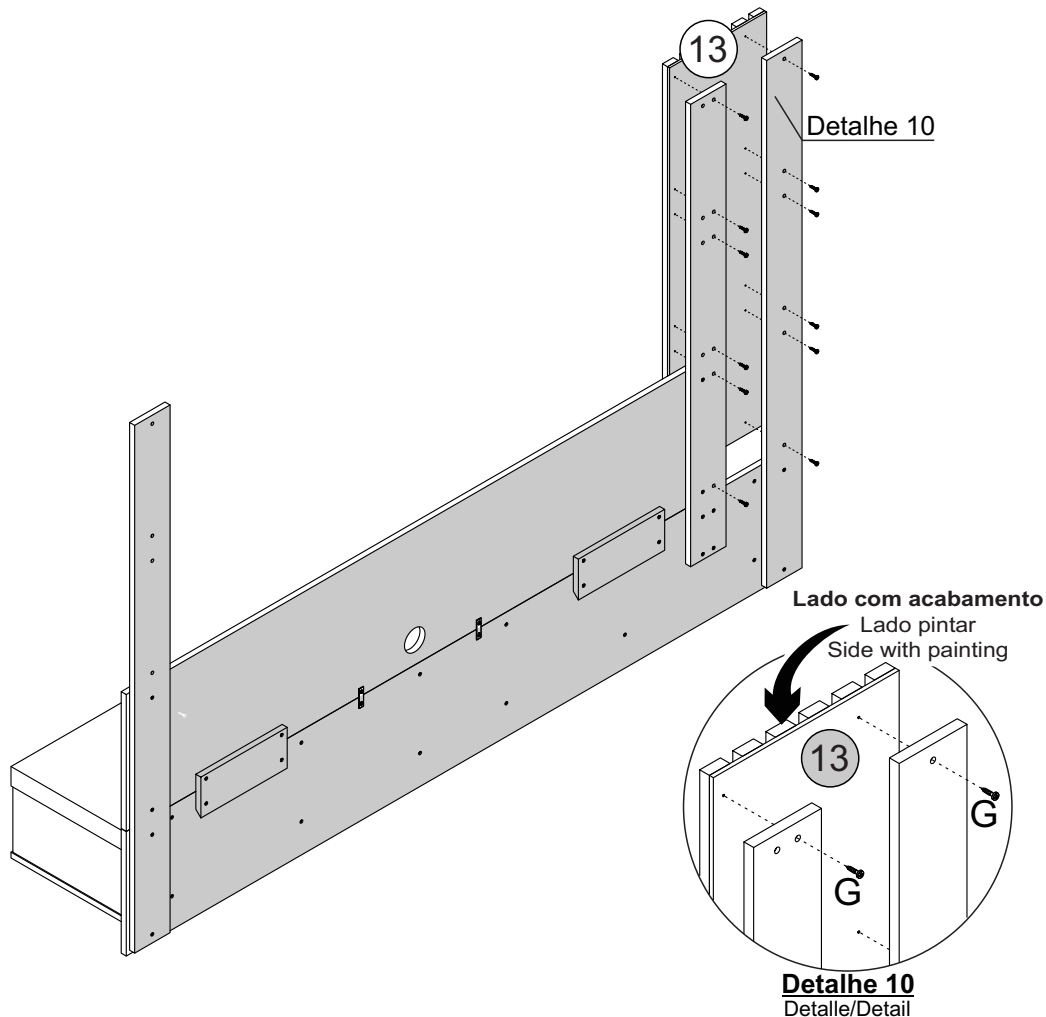
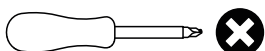

Passo 10

Paso/Step

PEÇA
Pieza/Piece

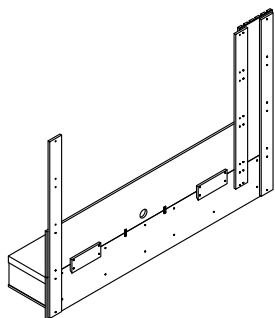

3 - PAINEL CENTRAL x1

FERRAGEM
Herraje/Hardware

G  04

FERRAMENTA
Herramienta/Tool

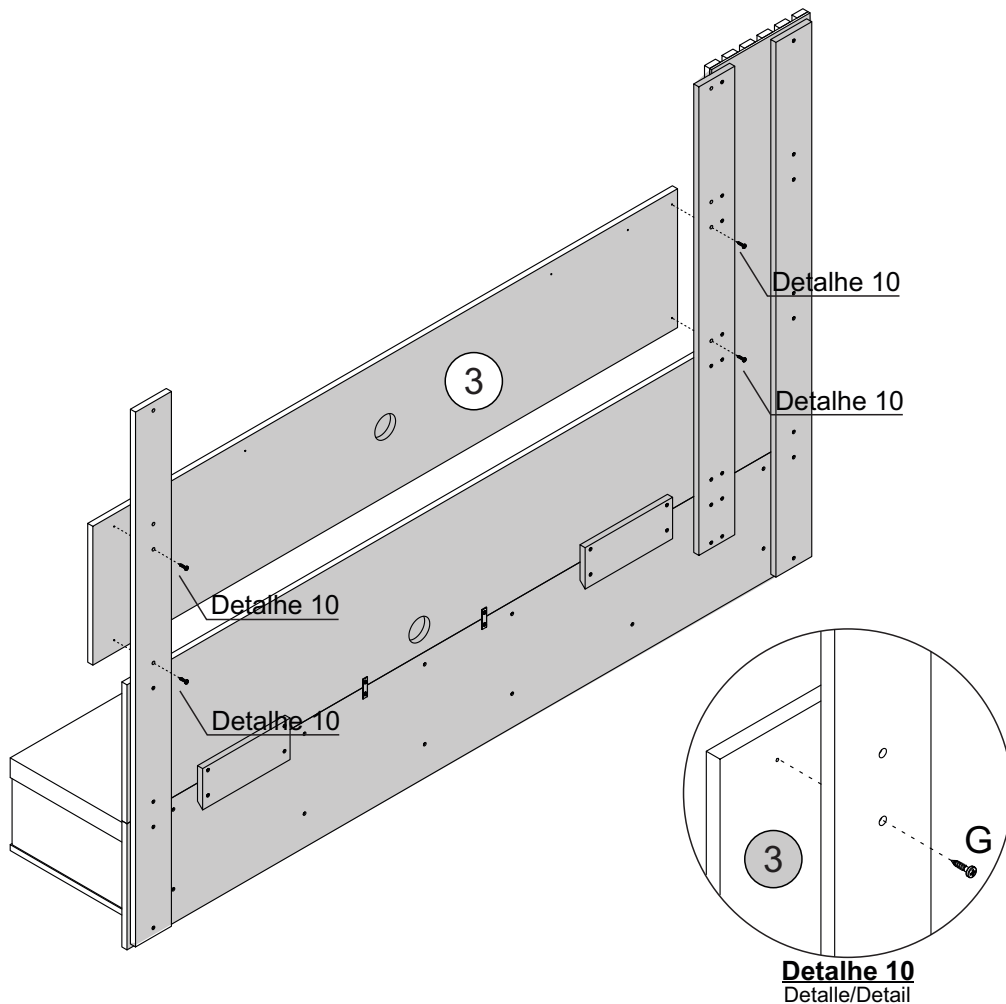
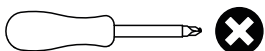

Passo 11

Paso/Step

PEÇA
Pieza/Piece

4 - PAINEL SUPERIOR x1

11 - PRATELEIRA x1

FERRAGEM
Herraje/Hardware

E  06

FERRAMENTA
Herramienta/Tool

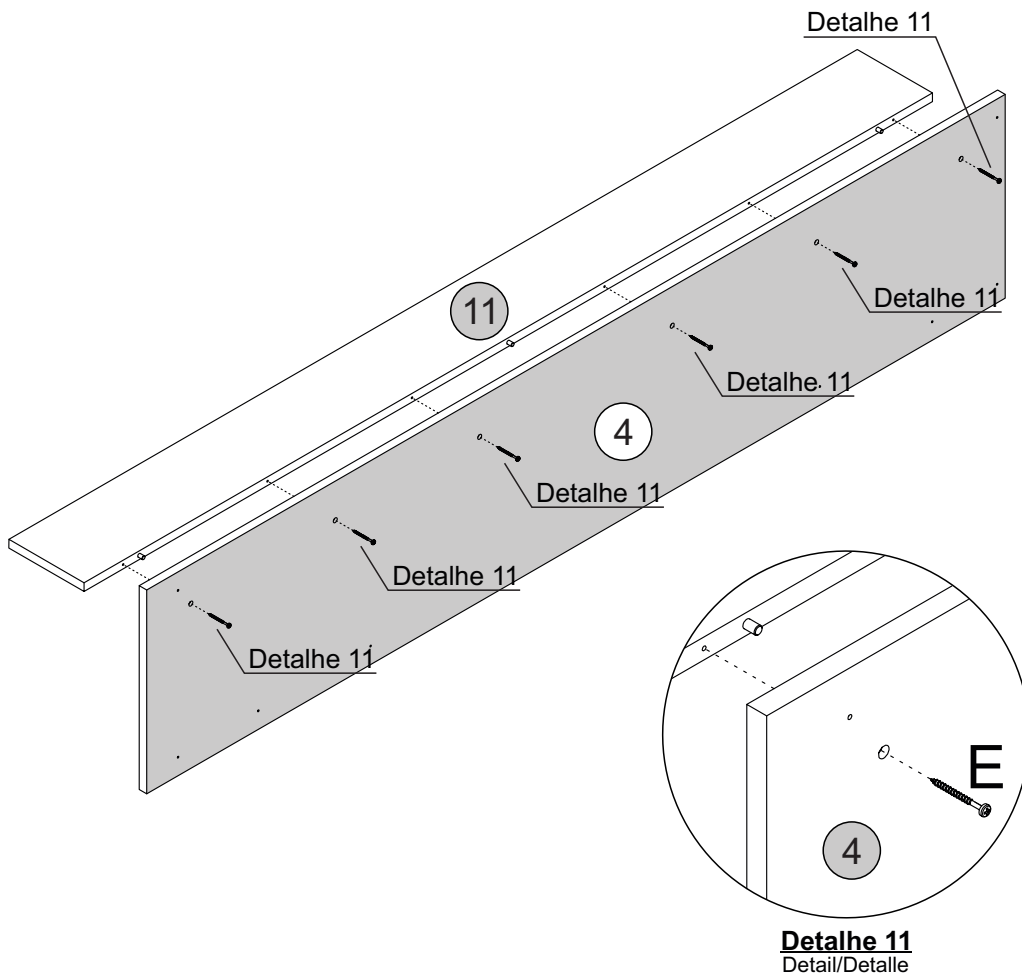
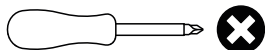

Passo 12

Paso/Step

PEÇA
Pieza/Piece

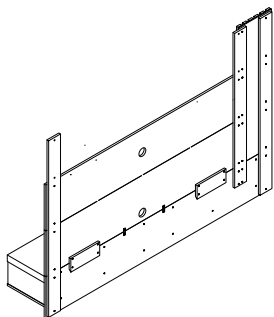

FERRAGEM
Herraje/Hardware

G  12

H  06

L  03

FERRAMENTA
Herramienta/Tool

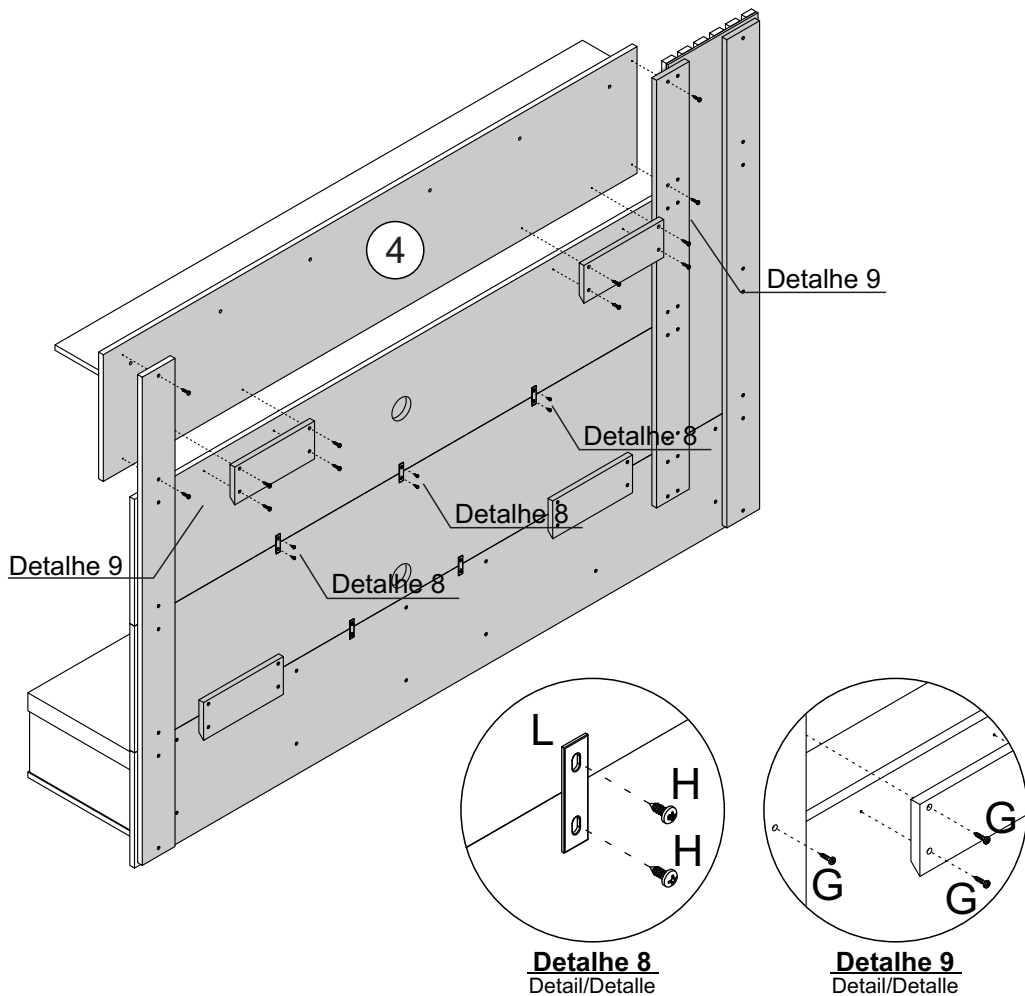
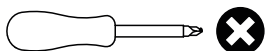

Passo 13

Paso/Step

PEÇA
Pieza/Piece

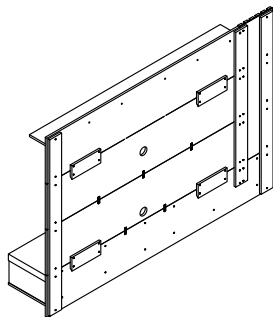

FERRAGEM
Herraje/Hardware

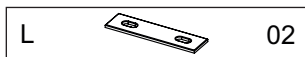

FERRAMENTA
Herramienta/Tool

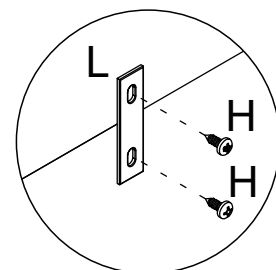
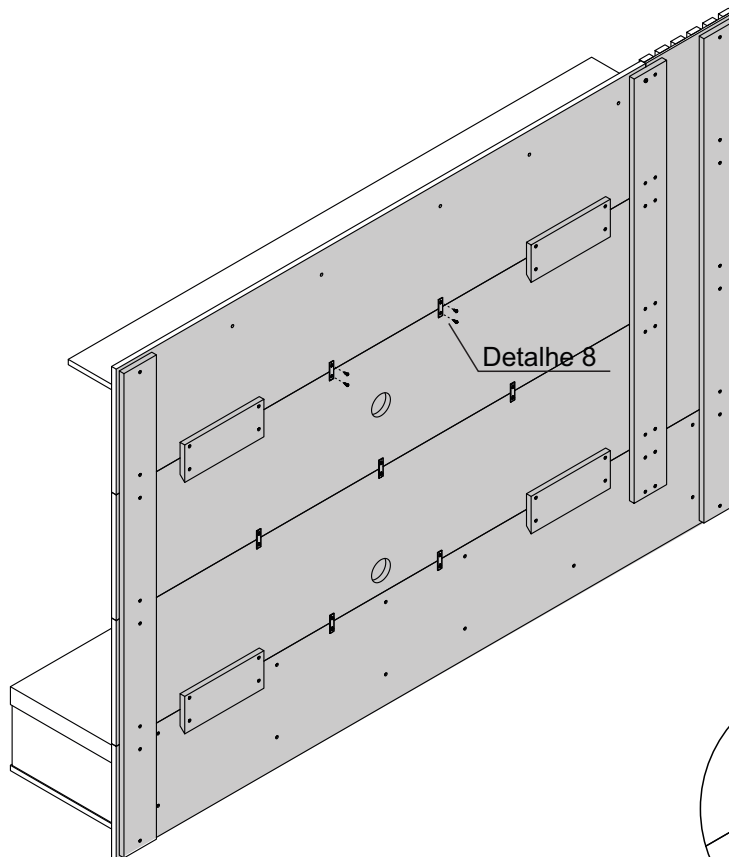
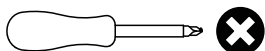

Detalhe 8
Detail/Detaille

Passo 14

Paso/Step

PEÇA
Pieza/Piece

16 - FRENTE GAVETA x3

17 - LATERAL GAVETA x6

18 - TRASEIRA GAVETA x3

20 - TRAVESSA GAVETA x3

FERRAGEM
Herraje/Hardware

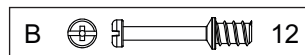
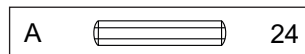

FERRAMENTA
Herramienta/Tool

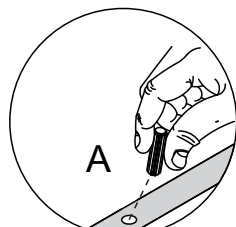
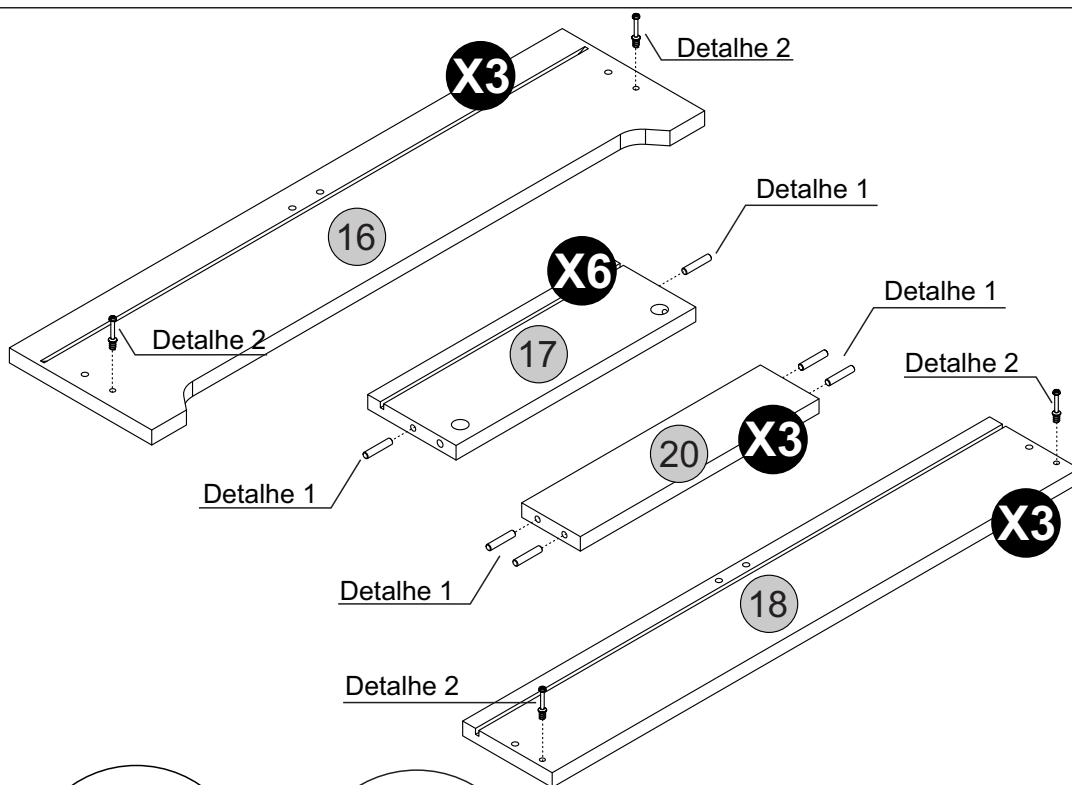
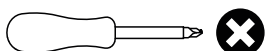

Detalhe 1
Detail/Detaille

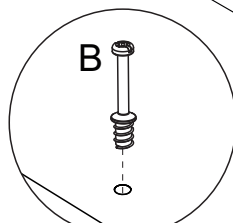

Detalhe 2
Detalle/Detail

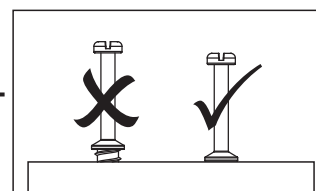

Passo 15

Paso/Step

PEÇA
Pieza/Piece

16 - FRENTE GAVETA x3



17 - LATERAL GAVETA x6

18 - TRASEIRA GAVETA x3

19 - FUNDO GAVETA x3

20 - TRAVESSA GAVETA x3

FERRAGEM
Herraje/Hardware

C   12

D  12

FERRAMENTA
Herramienta/Tool

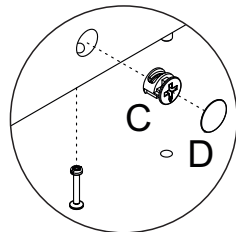
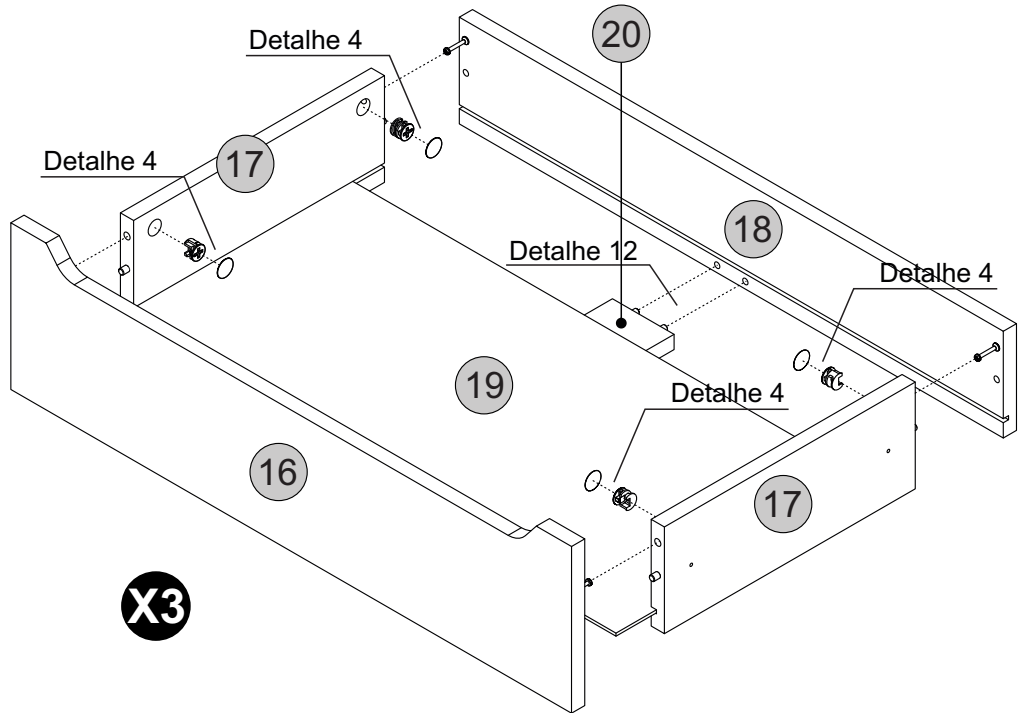
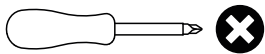

Detalhe 4
Detalle/Detail

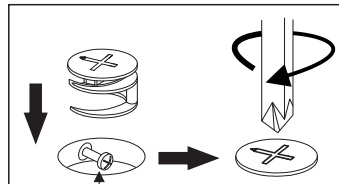

Cabeça do parafuso precisa estar no centro
La cabeza del tornillo debe estar en el centro
Screw head has to be in the center

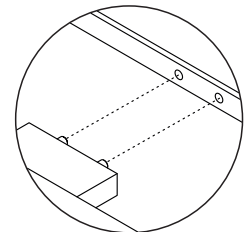

Detalhe 12
Detalle/Detail



Passo 16

Paso/Step

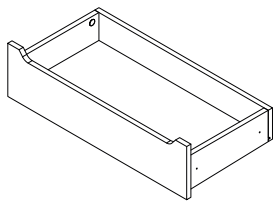
PEÇA
Pieza/Piece



FERRAGEM
Hardware/Herraje

I   12

K  06

FERRAMENTA
Tool/Herramienta

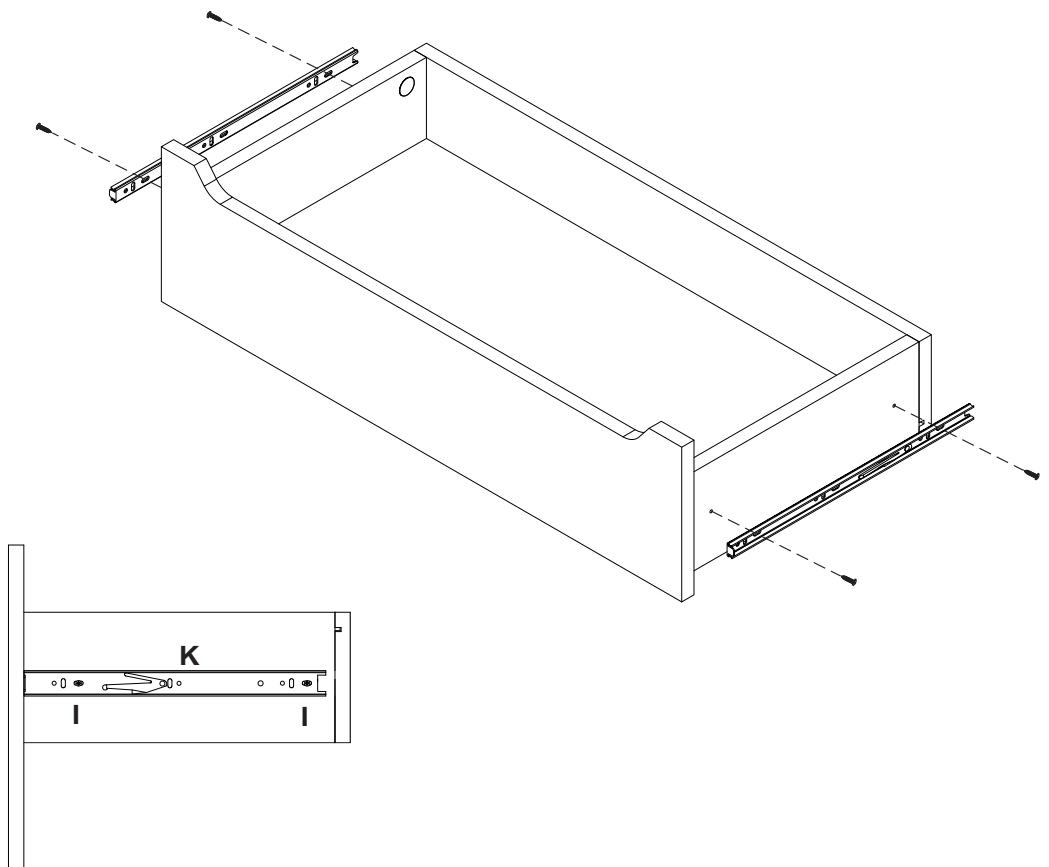
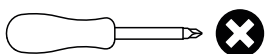

Passo 17

Paso/Step

PEÇA
Piece/Pieza

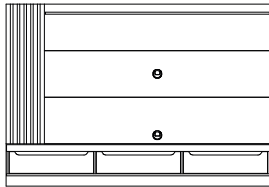

FERRAGEM
Hardware/Herraje

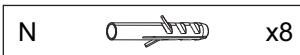
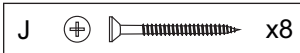

FERRAMENTA
Tool/Herramienta

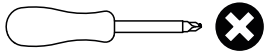

Esquema de furação da parede / Esquema de perforación de la pared / Wall drilling Scheme

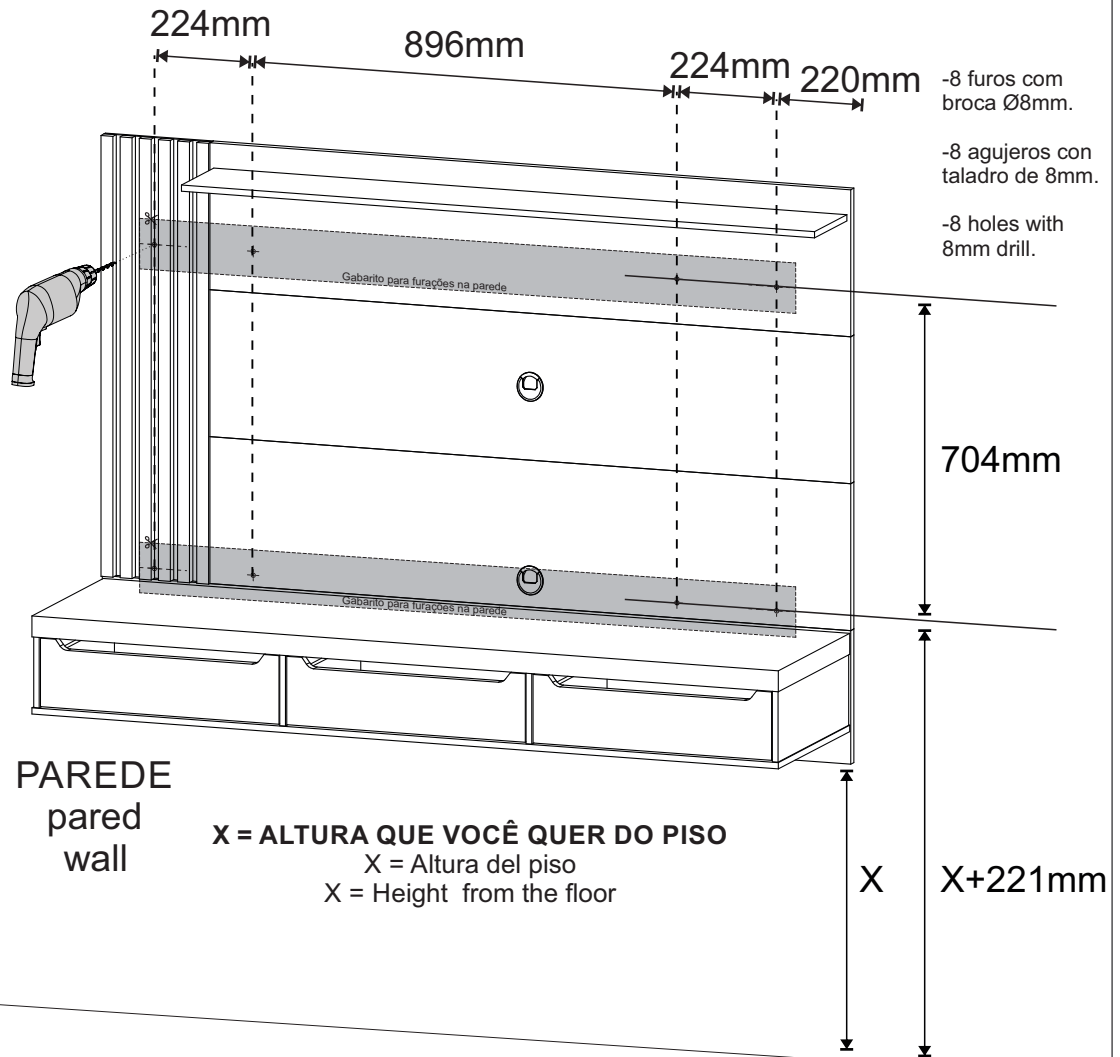

Obs: -Nivelar as travessas na parede.
-Nivelar los travesaños en la pared.
-Level the crosspieces on the wall.

Ex: Se você quer que o painel fique a 500mm do piso:

Altura do primeiro furo = $500+221=721\text{mm}$
Altura do segundo furo = $721+704=1425\text{mm}$.

Ejemplo:

Si desea que el panel esté a 500 mm del piso:
Altura del primer agujero = $500+221=721\text{mm}$
Altura del segundo agujero = $721+704=1425\text{mm}$.

Example:

If you want the panel to be 500mm from the floor:
Height of the first hole line = $500+221=721\text{mm}$
Height of second hole line = $721+704=1425\text{mm}$.

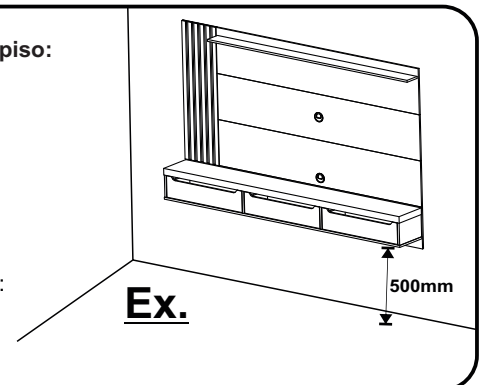

Fixar o gabarito na parede com fita.

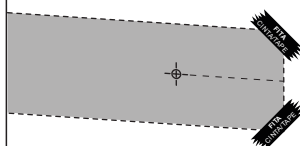

Put the template on the wall with tape.
Fije la plantilla a la pared con cinta adhesiva.

Furar a parede conforme o gabarito.

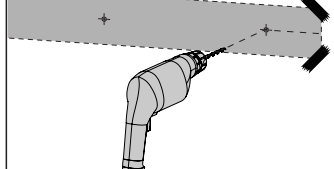

Drill the wall according to the template.
Taladre la pared de acuerdo con la plantilla.

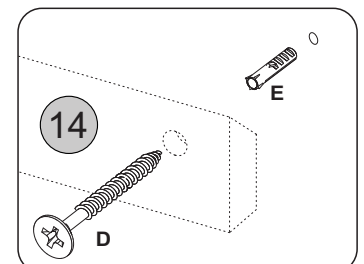

Passo 18

Paso/Step

PEÇA
Piece/Pieza

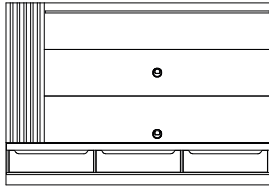

FERRAGEM
Hardware/Herraje

FERRAMENTA
Tool/Herramienta

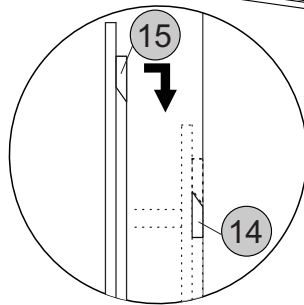
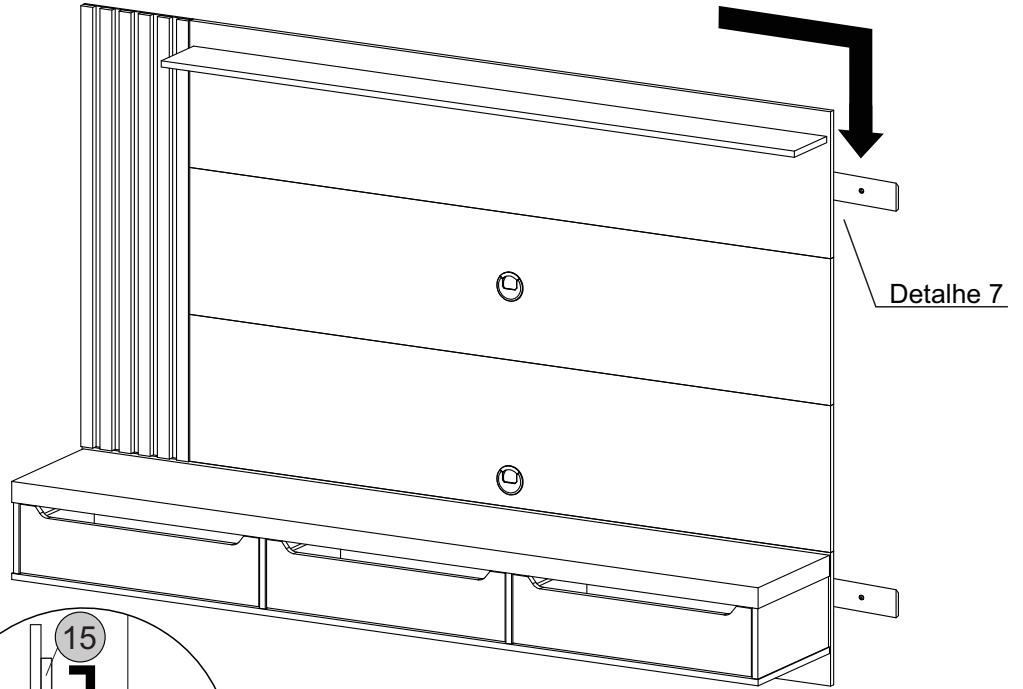

Detalhe 7
Detail/Detalle







Passo 19

Paso/Step

PEÇA
Piece/Pieza

FERRAGEM
Hardware/Herraje

FERRAMENTA
Tool/Herramienta

		kit suporte TV			
O					2
	O1 35x77mm	O2 48x28mm	O3 100x56mm		
O6			Parafuso M6 x 16		4
O7			Parafuso M8 x 16		4

-Para facilitar a fixação do Suporte Universal, enviamos 2 modelos de parafusos que estão de acordo com os padrões mais usados pelos principais fabricantes de TVs LCD / LED / PLASMA / 3D do mercado. Caso nenhum dos 2 modelos se encaixe adequadamente ao seu televisor, adquira o parafuso compatível com sua TV em qualquer loja de ferragens. Para evitar danos à sua TV, não aperte demasiadamente os parafusos.

 -Para facilitar la colocación del soporte universal, enviamos 2 modelos de tornillos que cumplen con los estándares más utilizados por los principales fabricantes de televisores. Si ninguno de los modelos se ajusta a su televisor correctamente, compre el tornillo compatible con su televisor en cualquier ferretería. Para evitar daños a su televisor, no apriete demasiado los tornillos.

-To make it easier to attach the TV support, we send 2 screw models that match the most commonly used TVs. If neither model fits your TV properly, purchase the compatible screw from any hardware store. To prevent damage to your TV, do not over tighten the screws.

Passo 20

Paso/Step

PEÇA
Piece/Pieza

FERRAGEM
Hardware/Herraje

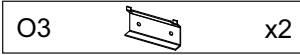
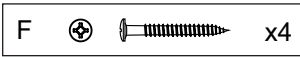

FERRAMENTA
Tool/Herramienta

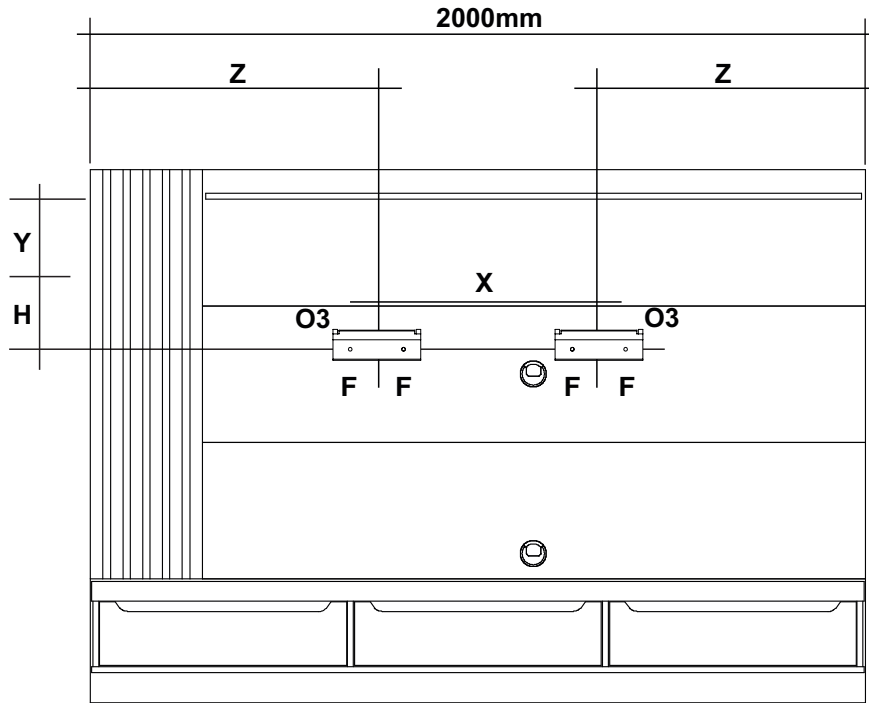
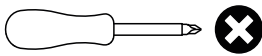

Y = Altura desejada para a TV.

Y = Useful height above the TV.

Y = Altura sobre el TV.

H = Distância dos furos da TV até a borda.

H = Distance from the TV holes to the TV border.

H = Distancia desde los orificios del TV hasta el borde del TV.

X = Distância entre os furos da sua TV.

X = Distance between the TV holes.

X = Distancia entre los orificios del TV.

Passo 21

Paso/Step

PEÇA
Piece/Pieza

FERRAGEM
Hardware/Herraje



FERRAMENTA
Tool/Herramienta

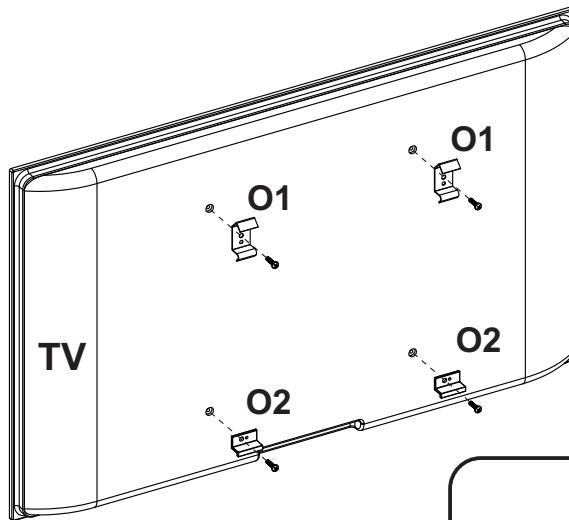
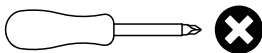

Suporte Superior

Soporte superior / Upper support

Utilizar o parafuso indicado no manual da TV O6,O7(VESA).

Use el tornillo indicado del televisor manual O6,O7(VESA).

Use the screw indicated the TV's manual O6,O7(VESA).

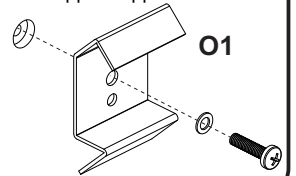

Suporte Inferior

Soporte inferior / Lower support

Utilizar o parafuso indicado no manual da TV O6,O7(VESA).

Use el tornillo indicado del televisor manual O6,O7(VESA).

Use the screw indicated the TV's manual O6,O7(VESA).

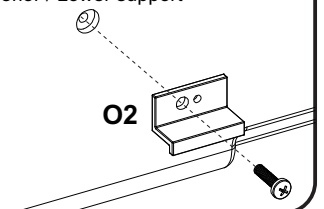

Passo 22

Paso/Step

PEÇA
Piece/Pieza

FERRAGEM
Hardware/Herraje

FERRAMENTA
Tool/Herramienta

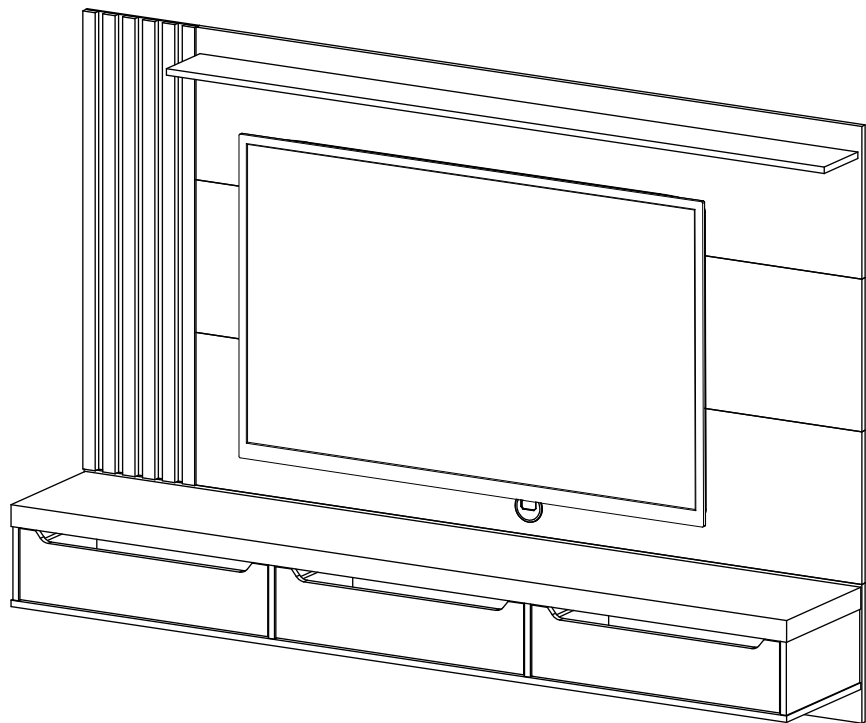
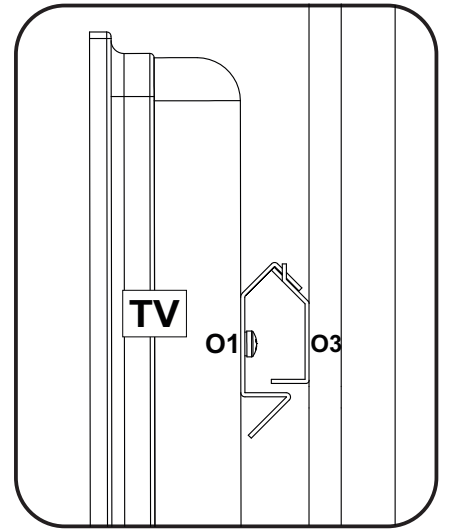
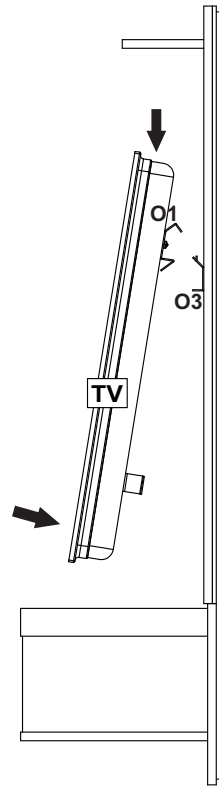



Parabéns, você montou seu móvel! Agora é só decorar sua casa e aproveitar!

Queremos ver como ficou o móvel Artely do seu jeito... Marque a gente com a #meuartely. Ficaremos felizes em compartilhar!

Ah, e se tiver qualquer dúvida, sugestão ou comentário, entra em contato com a gente pelo nosso site www.artely.com.br.

¡Congratulaciones, montaste tu mueble! ¡Ahora solo decora tu casa y disfruta!

Queremos ver este producto en tu hogar, a tu manera... Utilice #meuartely, ¡ficaremos encantados de compartir tu foto!

Si tienes alguna duda, sugerencia o comentario, contáctenos a través de nuestro sitio web www.artely.com.br.

Congratulations, you've assembled your new furniture! Decorate your home and enjoy!

We want to see how this product is in your home... Use #meuartely, we will be happy to share your picture!

If you have any doubt, suggestion or comment, get in touch with us through our website www.artely.com.br.

