



Para facilitar a fixação do Suporte Universal, enviamos 2 modelos de parafusos que estão de acordo com os padrões mais usados pelos principais fabricantes de TVs LCD / LED / PLASMA / 3D do mercado. Caso nenhum dos 2 modelos se encaixe adequadamente ao seu televisor, adquira o parafuso compatível com sua TV em qualquer loja de ferragens. Para evitar danos à sua TV, não aperte demasiadamente os parafusos.



Atenção

Retirar a TV do painel sempre que:

- Mover o painel
- Manusear os cabos por trás do painel
- Passar novos cabos

- Se a tomada estiver atrás do painel, cuide para que os cabos não fiquem forçando o painel para a frente.

Passos para retirar a TV do painel:

1



Atenção

A TV não sai para os lados devido às travas de segurança do suporte.

VISTA LATERAL

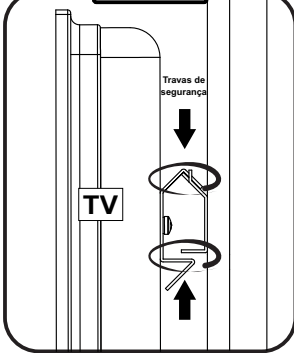

2

Inclinar um pouco a parte de baixo da TV até passar a trava de segurança inferior

VISTA LATERAL

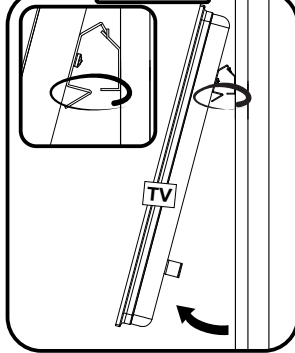

3

Elevar a TV retirando-a totalmente do suporte

VISTA LATERAL

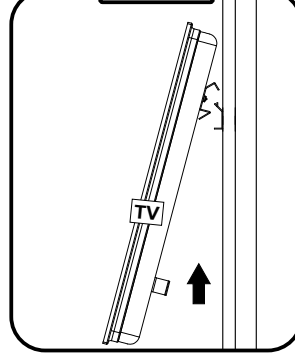

4

Desconectar todos os cabos da TV, retirando-a com segurança

VISTA LATERAL

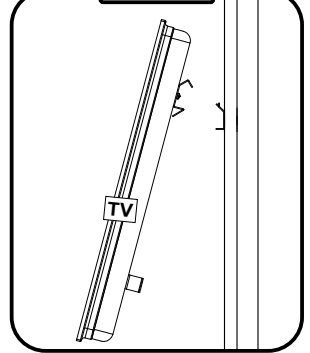

Este painel foi submetido a Testes de Resistência e suporta adequadamente o peso da TV. Não nos responsabilizamos por eventuais danos à TV causados por manuseio inadequado.



-Para una fácil fijación del soporte universal, enviamos 2 de los modelos de tornillos más utilizados en los televisores. Si ninguno encajar en su TV, busque otro en una ferretería. Para evitar daños en su televisor, no apriete demasiado los tornillos.
-To make it easier to attach the TV support, we send 2 screw models that match the most commonly used TVs. If neither model fits your TV properly, purchase the compatible screw from any hardware store. To prevent damage to your TV, do not over tighten the screws.



ATENCIÓN! ATTENTION!

Retire la TV del panel siempre que:

Take out the TV from the panel in the following situations:

- Mover el panel;
- You are moving the wall panel;
- Manejar los cables detrás del panel;
- You are handling the cables;
- Pasar nuevos cables.
- You are passing new cables.

- Si el tomacorriente está detrás del panel, tenga cuidado de que los cables no fuercen el panel adelante.

- If the power plug is behind the panel, be sure that the cables are not forcing the panel forward.

Pasos para retirar la televisión del panel: Steps to remove the TV from the wall panel:

1

-La TV no sale para los lados, debido a las travas de seguridad del soporte;

-There are safety locks in the support that keep the TV in its place. You can not take out the TV moving it to the sides.

VISTA LATERAL
SIDE VIEW

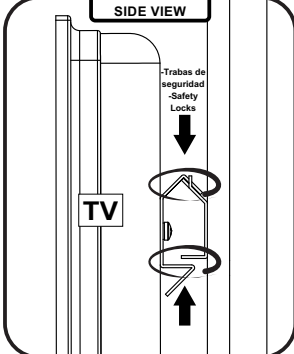

2

-Incline la parte inferior del televisor ligeramente hasta que pase la trava de seguridad inferior;

-Incline the bottom of the TV so that it passes the lower safety lock.

VISTA LATERAL
SIDE VIEW

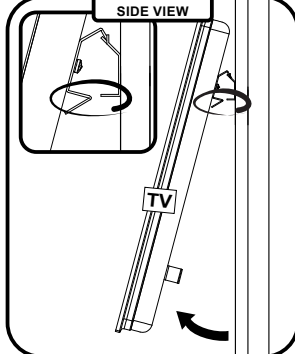

3

-Levante el televisor quitándolo completamente del soporte;

-Lift the TV, removing it completely from the support.

VISTA LATERAL
SIDE VIEW

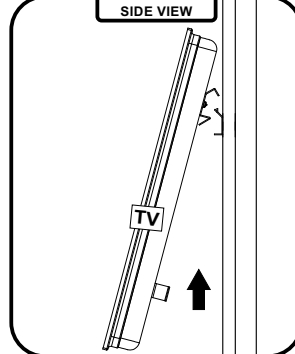

4

-Desconecte todos los cables de la TV, quitándola con seguridad.

-Disconnect all the TV cables and remove the TV safely.

VISTA LATERAL
SIDE VIEW

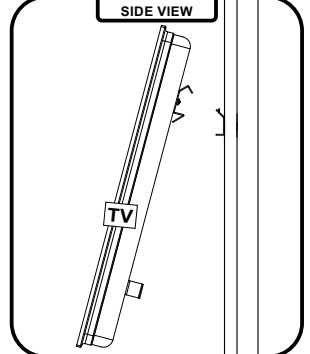

-Ese panel fue sometido a Pruebas de Resistencia y soporta adecuadamente el peso del televisor. No somos responsables de ningún daño al televisor causado por manejo inadecuado.
-This panel has undergone resistance tests and adequately supports the weight of the TV. We are not responsible for TV damage caused by inappropriate handling.



Painel Império

Rack Lumina / Estante Lumina
Versão 1.0 / Versión 1.0 / 1.0 Version

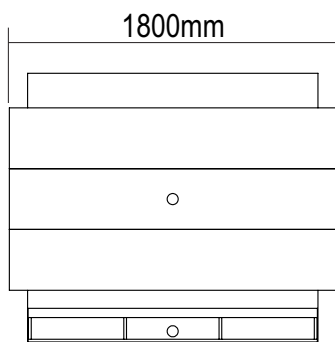

frente/frente/front
340mm

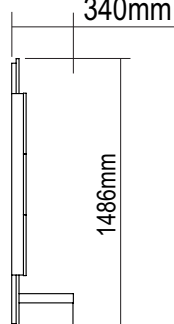

lateral/lado/side

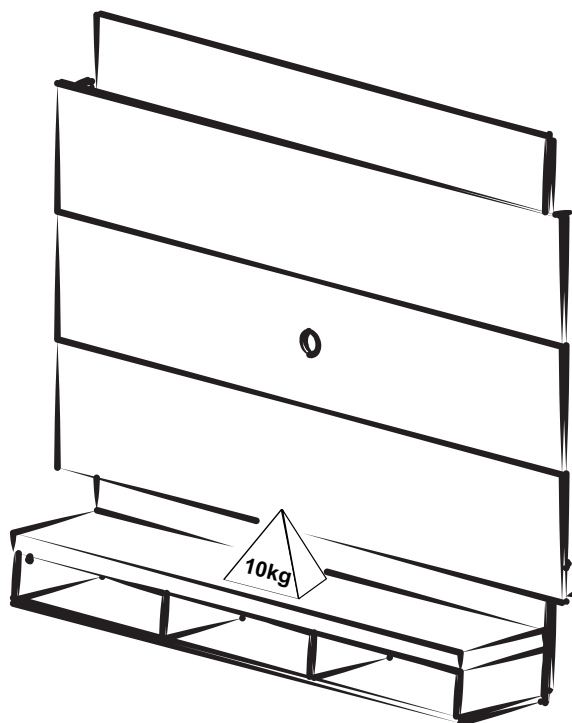

Conservação e Limpeza - Conservación y Limpieza - Conservation and Cleaning

Não expor o produto ao sol, altas temperaturas e umidade. Não arrastar objetos sobre a superfície do móvel (ex.: TV, DVD, aparelho de som, objetos decorativos...) e manter em local seco e arejado. Para a limpeza, utilizar um pano seco e macio. Não é necessário o uso de materiais abrasivos ou álcool.

No exponga el producto a la luz solar, las altas temperaturas y la humedad. No arrastre los objetos a través de la superficie de la unidad (por ejemplo, TV, DVD, equipo de música, objetos de decoración ...) Mantener en un lugar fresco y seco. Para la limpieza, utilizar un paño seco y suave. El uso de materiales abrasivos o del alcohol no es necesario.

Do not expose the product to sunlight, high temperatures and humidity. Do not drag objects across the surface of the unit (TV, DVD, stereo, decorative objects ...) keep it in a cool dry place. For cleaning, use a dry and soft cloth. Do not use abrasive materials or alcohol.

Garantia

Este certificado de Garantia é uma vantagem adicional oferecida ao consumidor, porém para que o mesmo tenha validade é imprescindível que seja apresentada a NOTA FISCAL de compra do produto.

Com este produto, a Artely tem como objetivo atender plenamente o proprietário-consumidor, proporcionando a garantia na forma aqui estabelecida, pelo período de três meses a partir da data da nota fiscal de compra. A Artely restringe a sua responsabilidade à substituição gratuita das peças defeituosas, em caso de defeitos ou avarias devidamente constatados como sendo de fabricação, durante a vigência desta garantia.

A Artely declara a garantia nula e sem efeito se o produto for alterado, adulterado, molhado ou consertado e ainda pela prática de montagem inadequada ou mau uso. Também será considerada nula em casos de força maior, como aqueles causados por agentes da Natureza (chuvas, incêndios, excesso de umidade, cupins,...) e eventos externos como objetos arrastados sobre a superfície do móvel (ex.: TV, DVD, aparelho de som, objetos decorativos...).

Para exercer seus direitos de comprador é importante que antes de montar seu produto você leia com atenção as instruções de cada passo do manual de montagem que acompanha o móvel.

Caso o produto não esteja em conformidade, entre em contato com a loja onde efetuou a compra ou com o nosso Serviço de Atendimento ao Cliente através do e-mail assistencia@artely.com.br ou pelo fone 41 3381 5000 e faça sua reclamação, apontando os defeitos técnicos observados, que teremos o maior prazer em atendê-lo. Para agilizar o seu atendimento, tenha sempre em mãos o manual de montagem com os respectivos números das peças defeituosas, conforme descritas no manual.

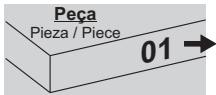



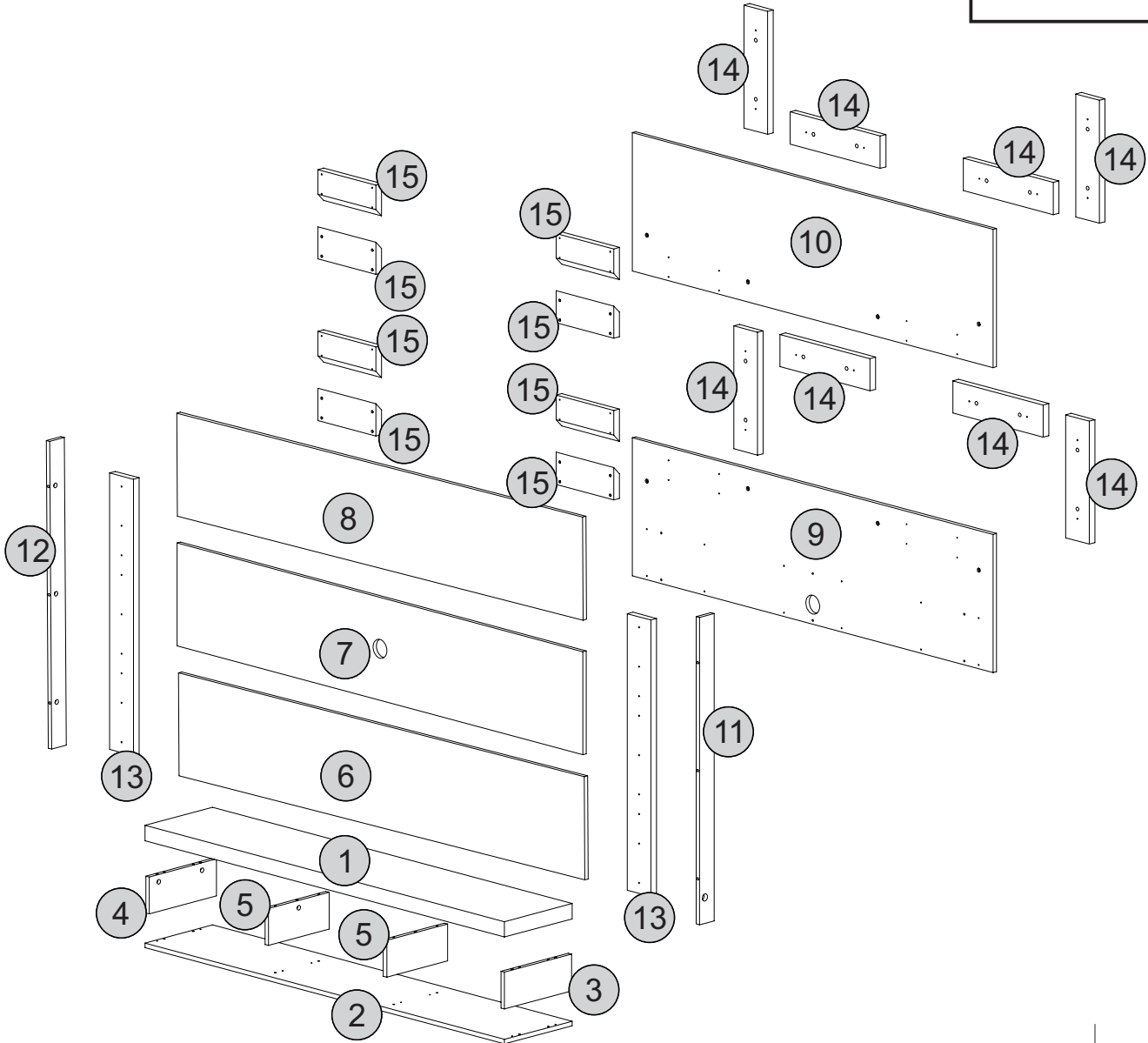
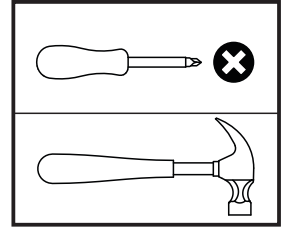



- O número na borda da peça corresponde ao manual.
- Para retirada do número usar Lustra-Móveis, Alcool em Gel ou Borracha.
- El número en el borde de la pieza coincide con el manual.
- Use una goma de borrar blanca, alcohol en gel o lustrador para muebles para eliminar los números.
- The number on the edge of the piece matches the manual.
- Use a White eraser, Alcohol Gel or Furniture Polish to remove the numbers.

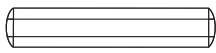
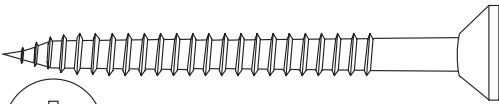
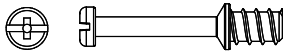

Descrição	Descripción	Description	Qty
1-Tampo (1595x300x50mm)	1-Tapa	1-Top	1
2-Base (1595x300x15mm)	2-Base	2-Middle Top	1
3-Lateral Direita (298x120x15mm)	3-Lado Derecho	3-Right Side	1
4-Lateral Esquerda (298x120x15mm)	4-Lado Izquierdo	4-Left Side	1
5-Divisão (270x120x15mm)	5-División	5-Division	2
6-Painel Inferior (1800x335x15mm)	6-Painel Inferior	6-Bottom Panel	1
7-Painel Central (1800x335x15mm)	7-Painel Central	7-Central Panel	1
8-Painel Superior (1800x335x15mm)	8-Painel Superior	8-Top Panel	1
9-Painel Traseiro Inferior (1600x450x15mm)	9-Painel Trasero Inferior	9-Lower Rear Panel	1
10-Painel Traseiro Superior (1600x450x15mm)	10-Painel Trasero Superior	10-Top Rear Panel	1
11-Travessa Direita (1000x65x15mm)	11-Travessana Derecha	11-Right Lane	1
12-Travessa Esquerda (1000x65x15mm)	12-Travessana Izquierdo	12-Left Alley	1
13-Travessa Maior (900x405x25mm)	13-Travessana Lateral	13-Side Tray	2
14-Travessa Lateral (400x105x25mm)	14-Travessana Grande	14-Larger Platter	8
15-Travessa Menor (256x105x25mm)	15-Travessana Pequena	15-Smaller Platter	8

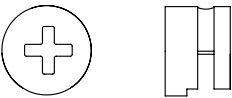
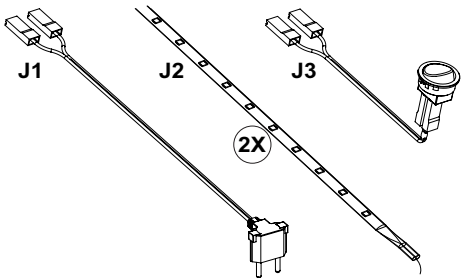
Lista de Materiais

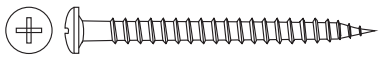
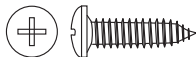
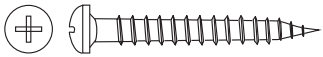
Lista de Materiales/ Hardware List

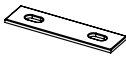
A		Cavilha / Tarugo / Dowel Ø6x30mm	22	H		Parafuso / Tornillo / Screw Ø5,5x65mm Cab 13	08
B		Minifix / Minifix / Minifix Ø7x30mm	12	I		Bucha / Casquillo / Bushing Ø8mm	08
C		Tambor / Tambor / Minifix Cam Ø15x12mm	12	J		Kit Luminária Kit de Luminaria / Light Fixture Kit	01
D		Tapa furo adesivo / Adhesivo / Hole Cover Ø18mm	06				
E		Parafuso Tornillo / Screw Ø3,5x40mm CP	20				
F		Parafuso Tornillo / Screw Ø4x14mm CP	12				
G		Parafuso Tornillo / Screw Ø4x30mm CP	70	K		Passa Fio / Pasacables / Cable Hole Cover Ø60mm	02
				L		Chapa Reta / Placa Recta / Mending Plate 50x13mm	06

DICAS PARA FIXAR MINIFIX

TIP TO FASTEN THE MINIFIX
PISTA PARA ARREGLAR EL MINIFIX

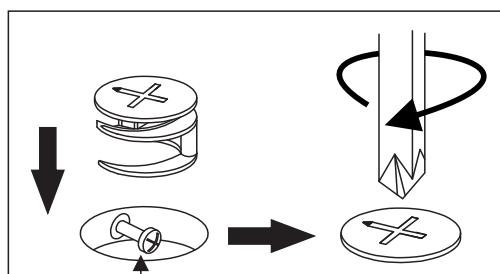

Cabeça do parafuso precisa estar no centro
La cabeza del tornillo debe estar en el centro
Screw head has to be in the center

Parafuso Minifix

Tornillo minifix/Minifix screw

Fixe o parafuso até o ressalto encostar na superfície da peça (veja o exemplo abaixo).

Tighten the screw until its overhang part lean on the piece surface (see the example below).

Fije el tornillo hasta que su parte sobressaliente toque la superficie de la pieza (vea el ejemplo abajo).

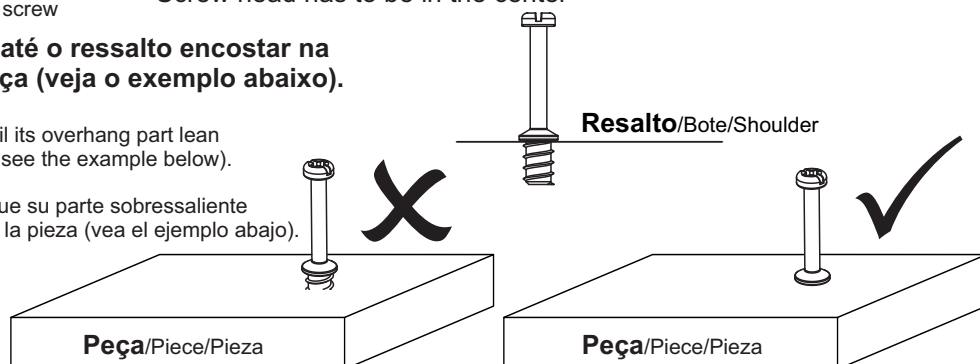

Passo 1

Paso/Step

PEÇA

Piece/Pieza

1 - TAMPO x1

FERRAGEM

Hardware/Herraje

A  03

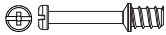
B  06

FERRAMENTA

Tool/Herramienta

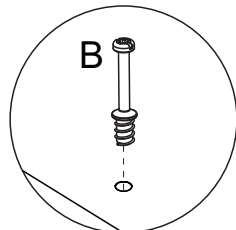
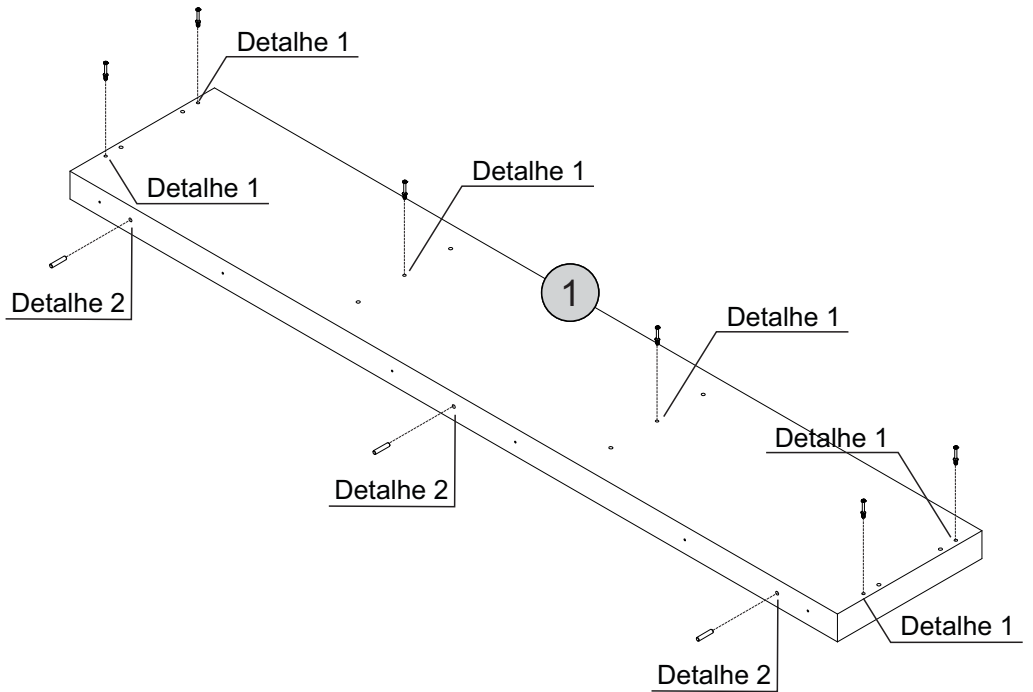
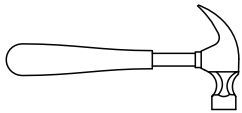
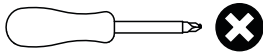

Detalhe 1
Detail/Detalle

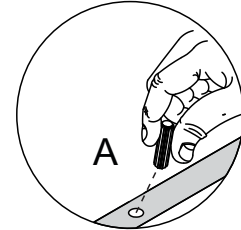
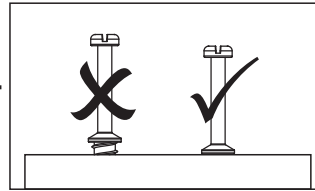

Detalhe 2
Detail/Detalle

Passo 2

Paso/Step

PEÇA

Piece/Pieza

2 - BASE x1

FERRAGEM

Hardware/Herraje

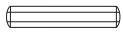
A  03

FERRAMENTA

Tool/Herramienta

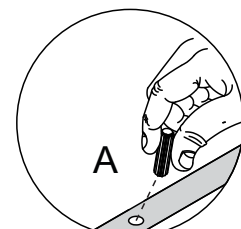
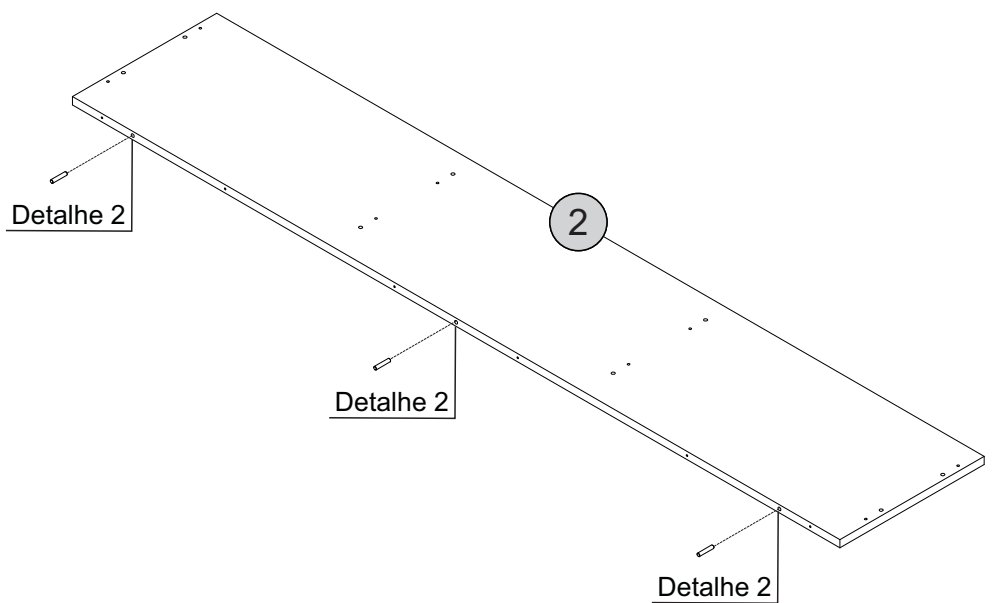
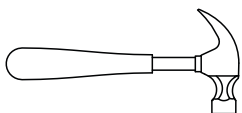
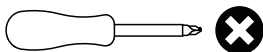

Detalhe 2
Detail/Detalle

Passo 3

Paso/Step

PEÇA
Piece/Pieza

3 - LATERAL DIREITA x1

4 - LATERAL ESQUERDA x1

FERRAGEM
Hardware/Herraje

A  08

FERRAMENTA
Tool/Herramienta

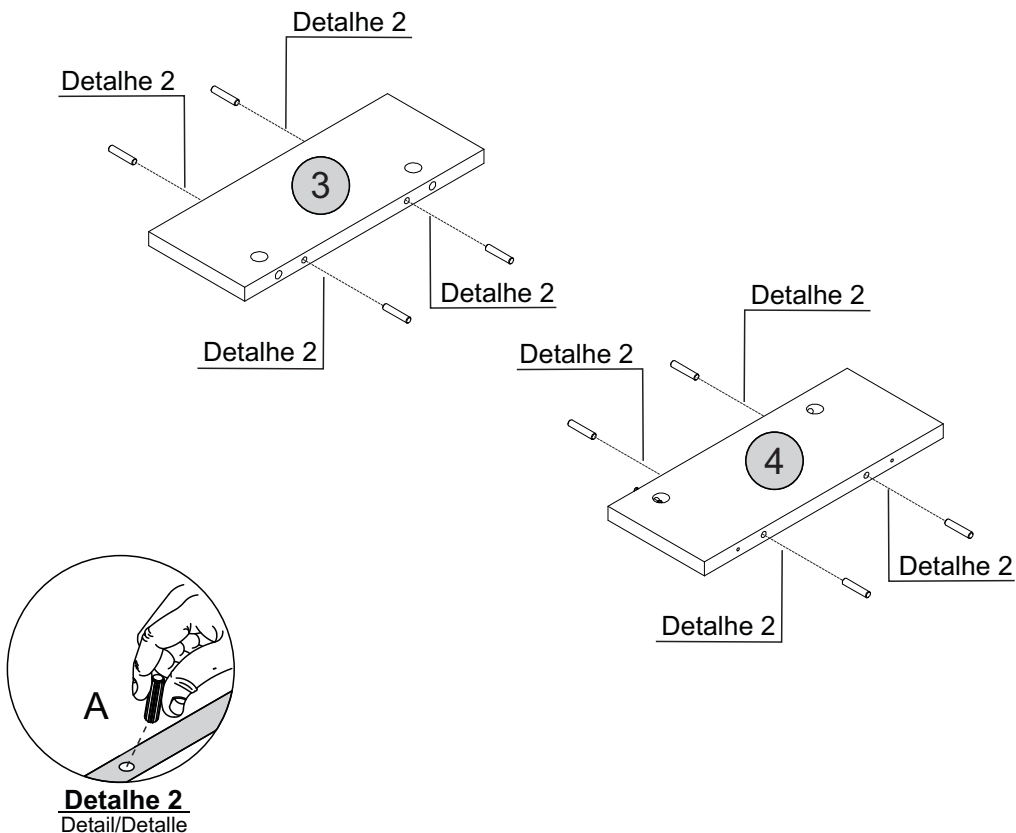
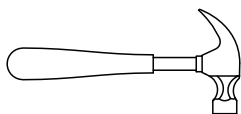

Passo 4

Paso/Step

PEÇA
Piece/Pieza

5 - DIVISÃO x2

FERRAGEM
Hardware/Herraje

A  08

FERRAMENTA
Tool/Herramienta

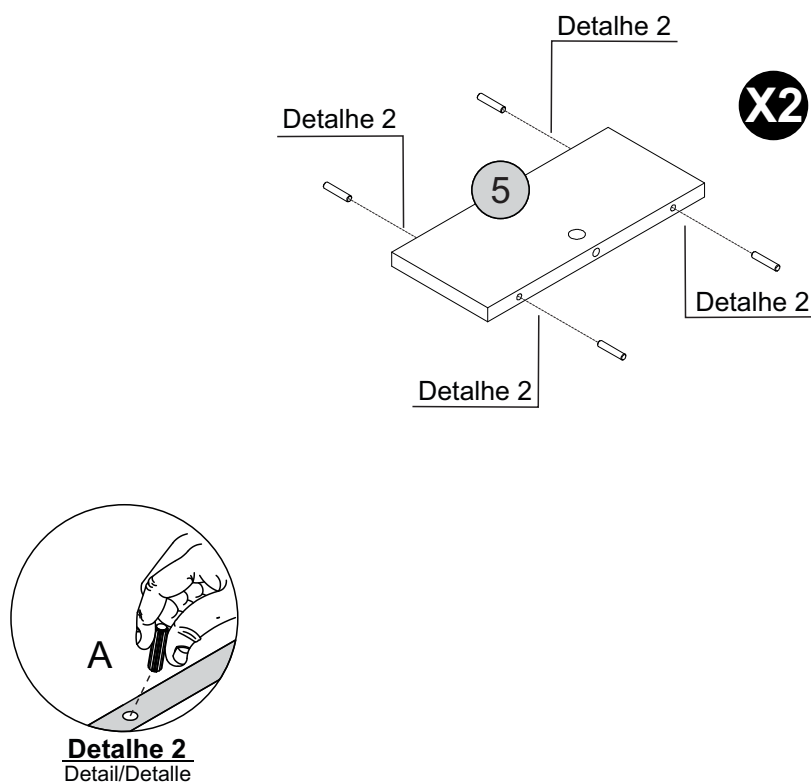
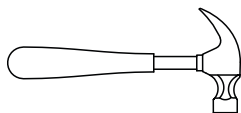

Passo 5

Paso/Step

PEÇA

Piece/Pieza

8 - PAINEL SUPERIOR x1

FERRAGEM

Hardware/Herraje

B  02

FERRAMENTA

Tool/Herramienta

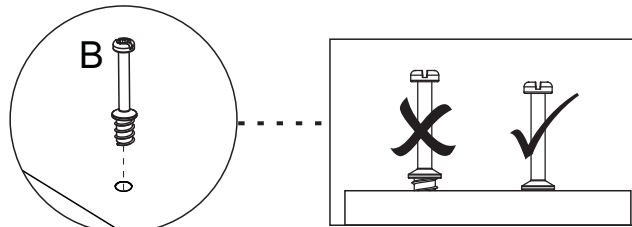
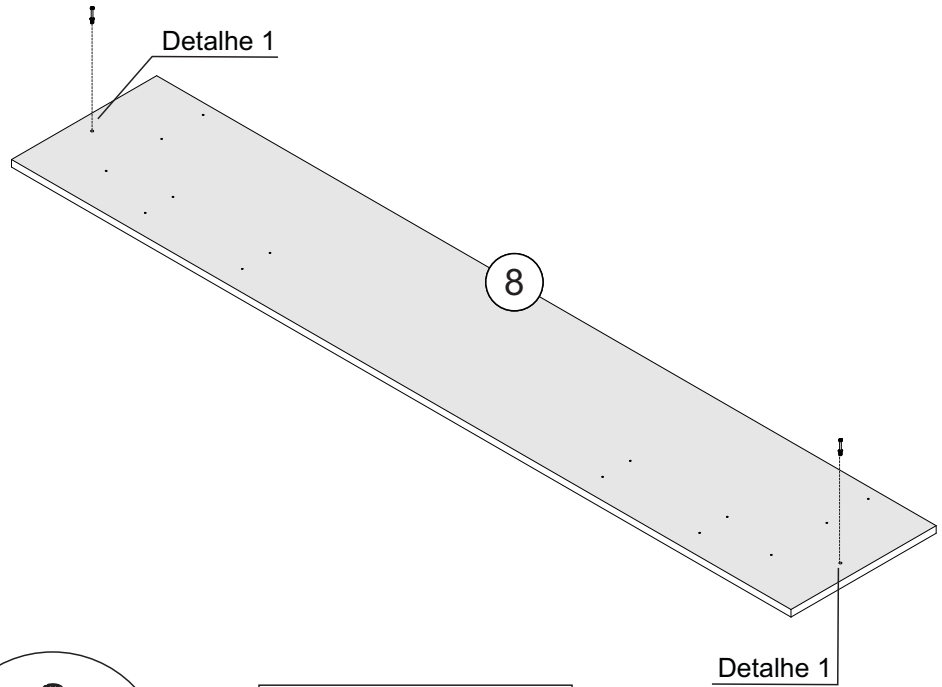
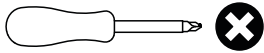

Detalhe 1
Detail/Detalle

Passo 6

Paso/Step

PEÇA

Piece/Pieza

7 - PAINEL CENTRAL x1

FERRAGEM

Hardware/Herraje

B  02

FERRAMENTA

Tool/Herramienta

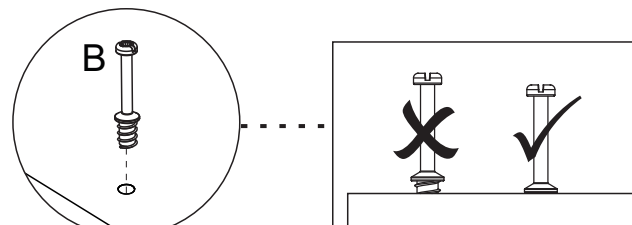
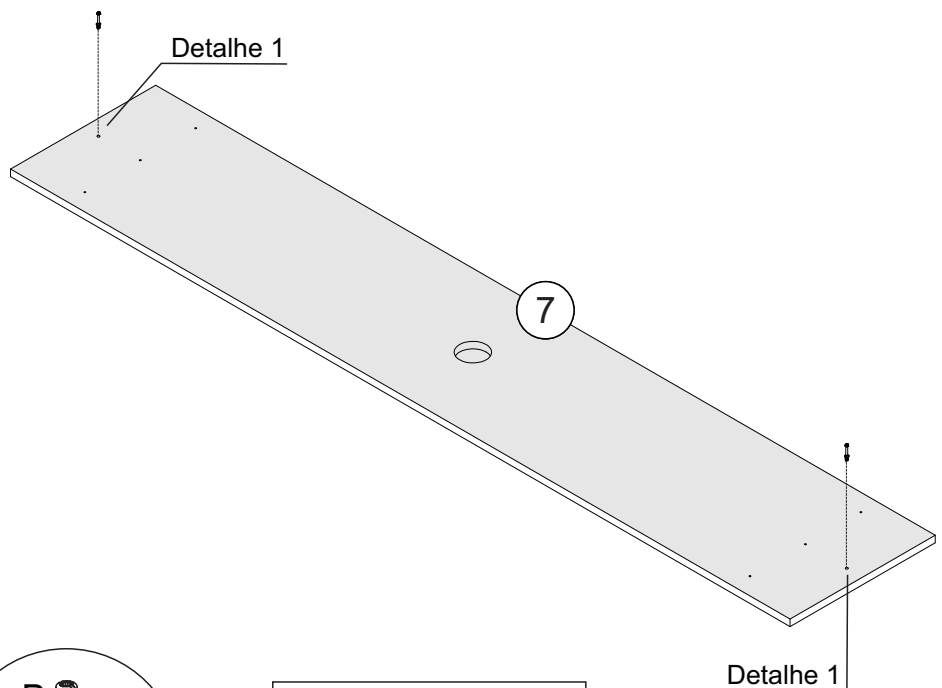
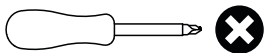

Detalhe 1
Detail/Detalle

Passo 7

Paso/Step

PEÇA

Piece/Pieza

6 - PAINEL INFERIOR x1

FERRAGEM

Hardware/Herraje

B  02

FERRAMENTA

Tool/Herramienta

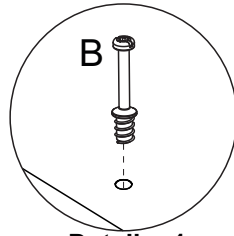
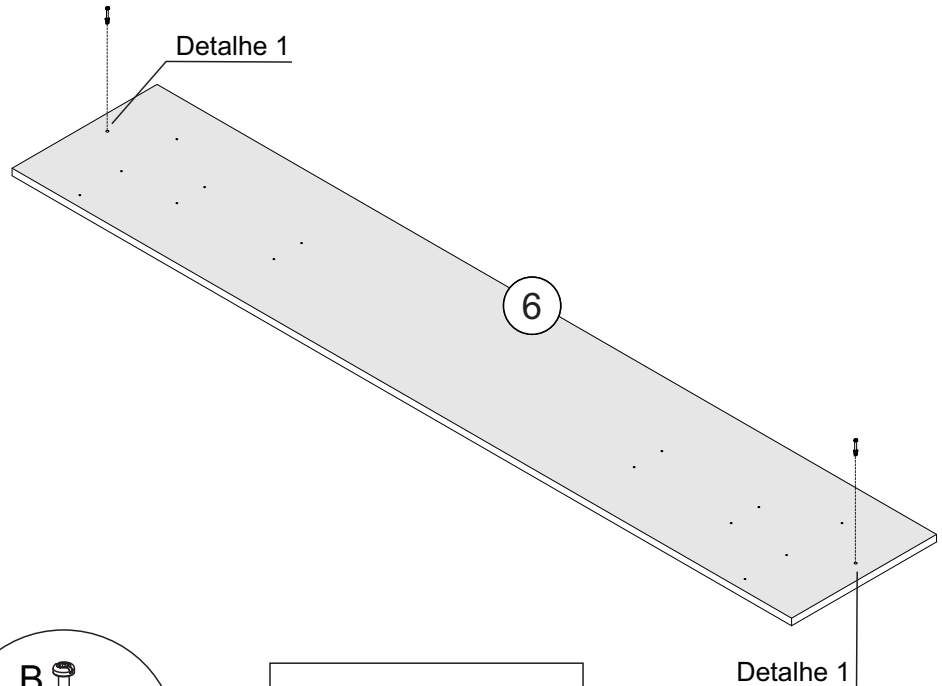
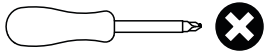

Detalhe 1
Detail/Detalle

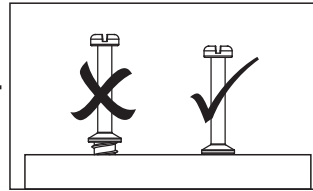

Passo 8

Paso/Step

PEÇA

Piece/Pieza

6 - PAINEL INFERIOR x1

7 - PAINEL CENTRAL x1

8 - PAINEL SUPERIOR x1

13 - TRAVESSA LATERAL x2

FERRAGEM

Hardware/Herraje

F  12

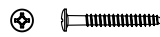
G  18

L  06

FERRAMENTA

Tool/Herramienta

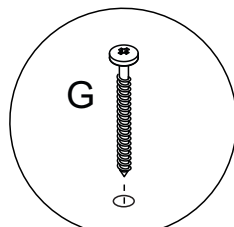
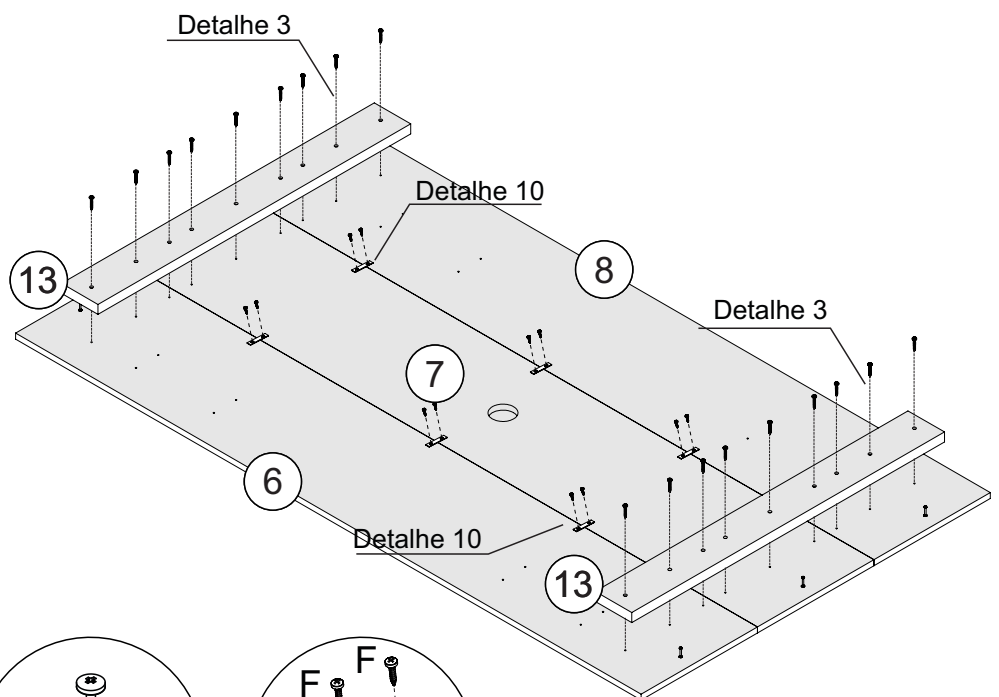
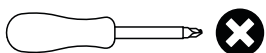

Detalhe 3
Detail/Detalle

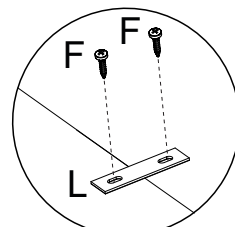

Detalhe 10
Detail/Detalle

Passo 9

Paso/Step

PEÇA

Piece/Pieza

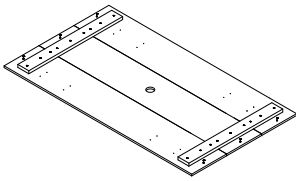

12 - TRAVESSA DIREITA x1

13 - TRAVESSA ESQUERDA x1



FERRAGEM

Hardware/Herraje

C   06

FERRAMENTA

Tool/Herramienta

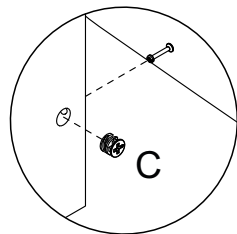
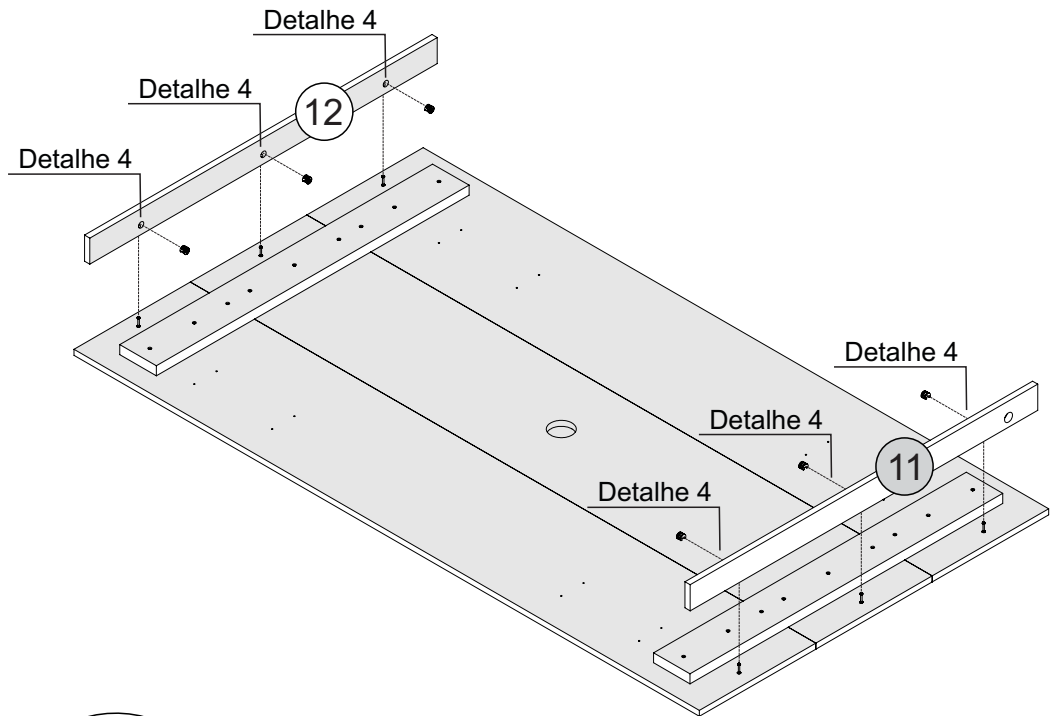
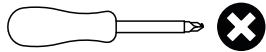

Detalhe 4
Detail/Detalle

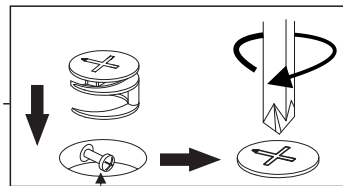

Cabeça do parafuso precisa estar no centro
La cabeza del tornillo debe estar en el centro
Screw head has to be in the center

Passo 10

Paso/Step

PEÇA

Piece/Pieza

15 - TRAVESSA MENOR x4

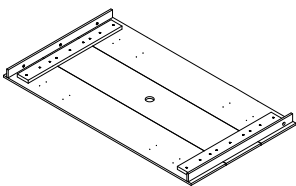

FERRAGEM

Hardware/Herraje

G  16

FERRAMENTA

Tool/Herramienta

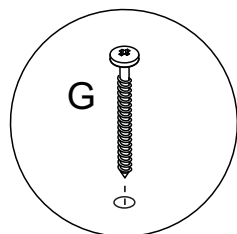
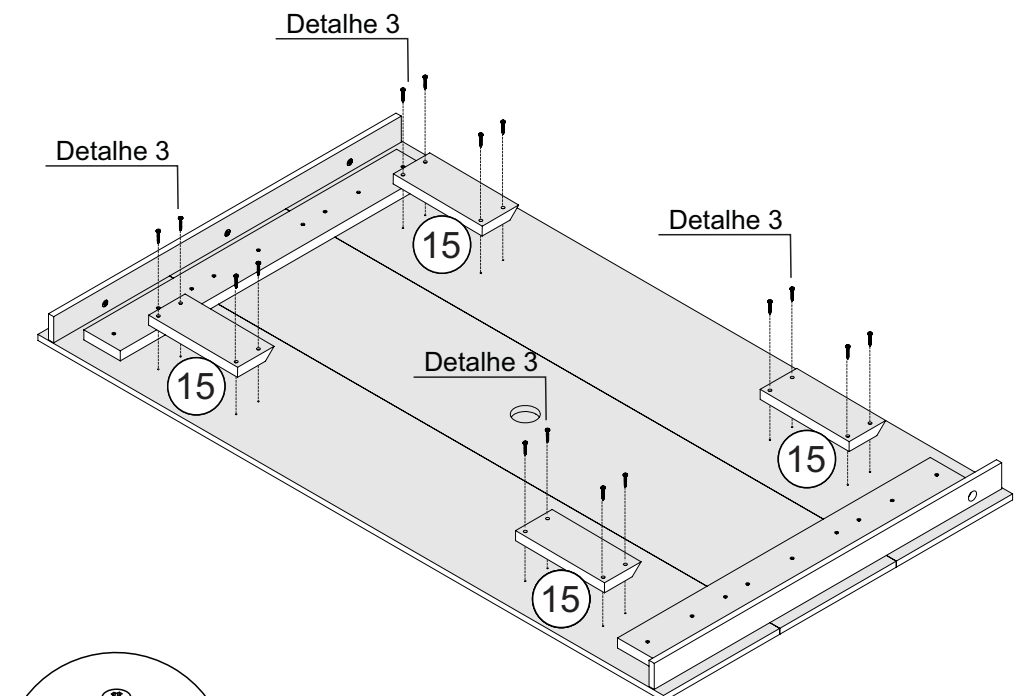
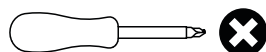

Detalhe 3
Detail/Detalle

Passo 11

Paso/Step

PEÇA
Piece/Pieza

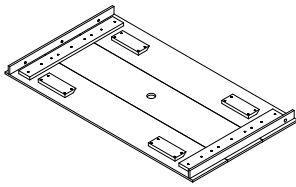

FERRAGEM
Hardware/Herraje

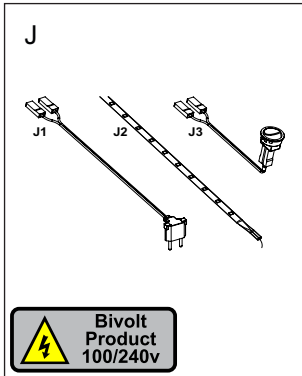

FERRAMENTA
Tool/Herramienta

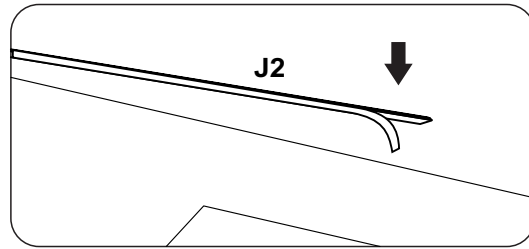
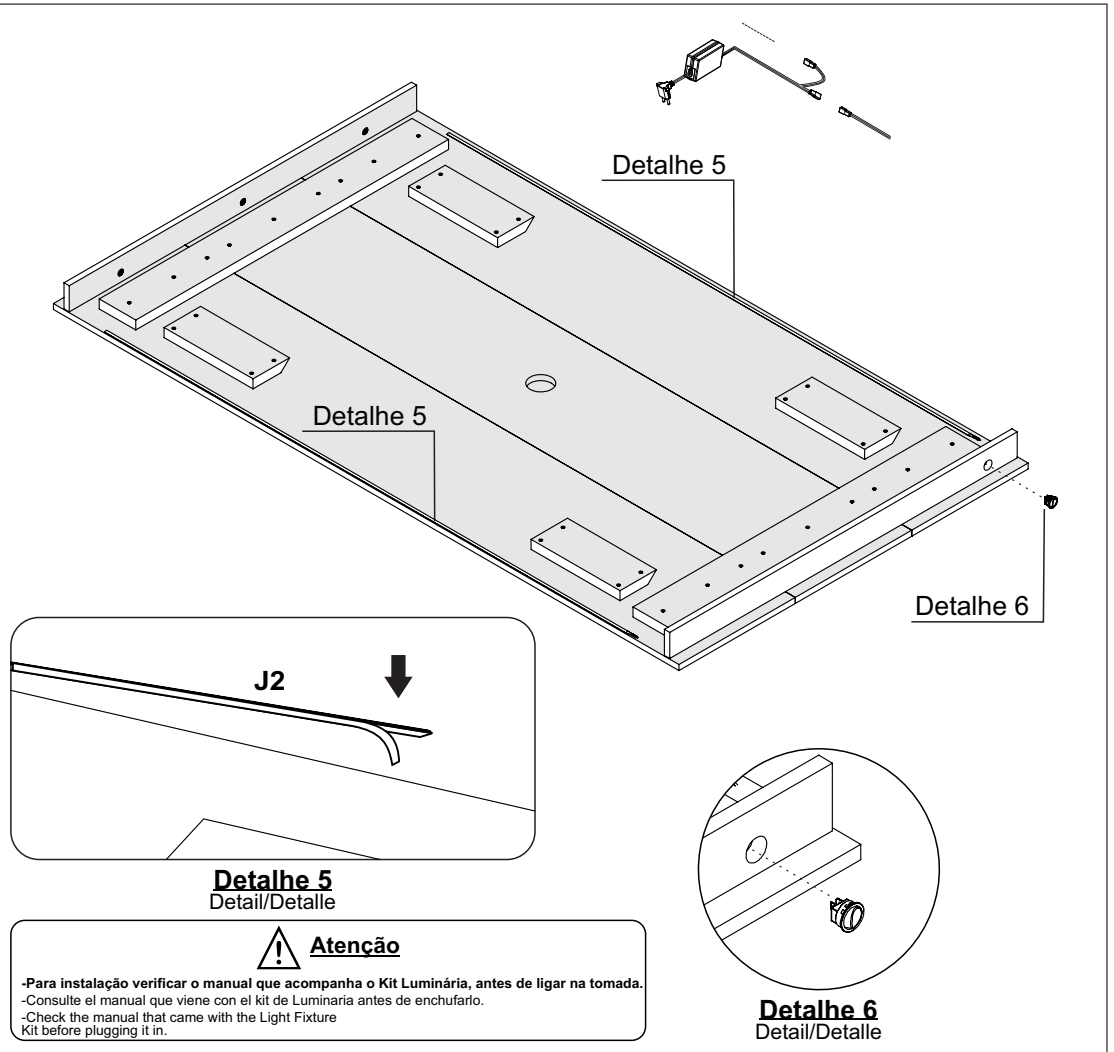
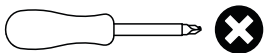

Detalhe 5
Detail/Detalle



Atenção

-Para instalação verificar o manual que acompanha o Kit Luminária, antes de ligar na tomada.
-Consulte el manual que viene con el Kit de Luminaria antes de enchufarlo.
-Check the manual that came with the Light Fixture Kit before plugging it in.

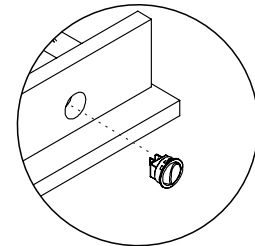

Detalhe 6
Detail/Detalle

Passo 12

Paso/Step

PEÇA
Piece/Pieza

1 - TAMPO	x1
3 - LATERAL DIREITA	x1
4 - LATERAL ESQUERDA	x1
5 - DIVISÃO	x1

FERRAGEM
Hardware/Herraje

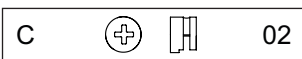

FERRAMENTA
Tool/Herramienta

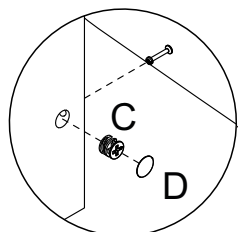
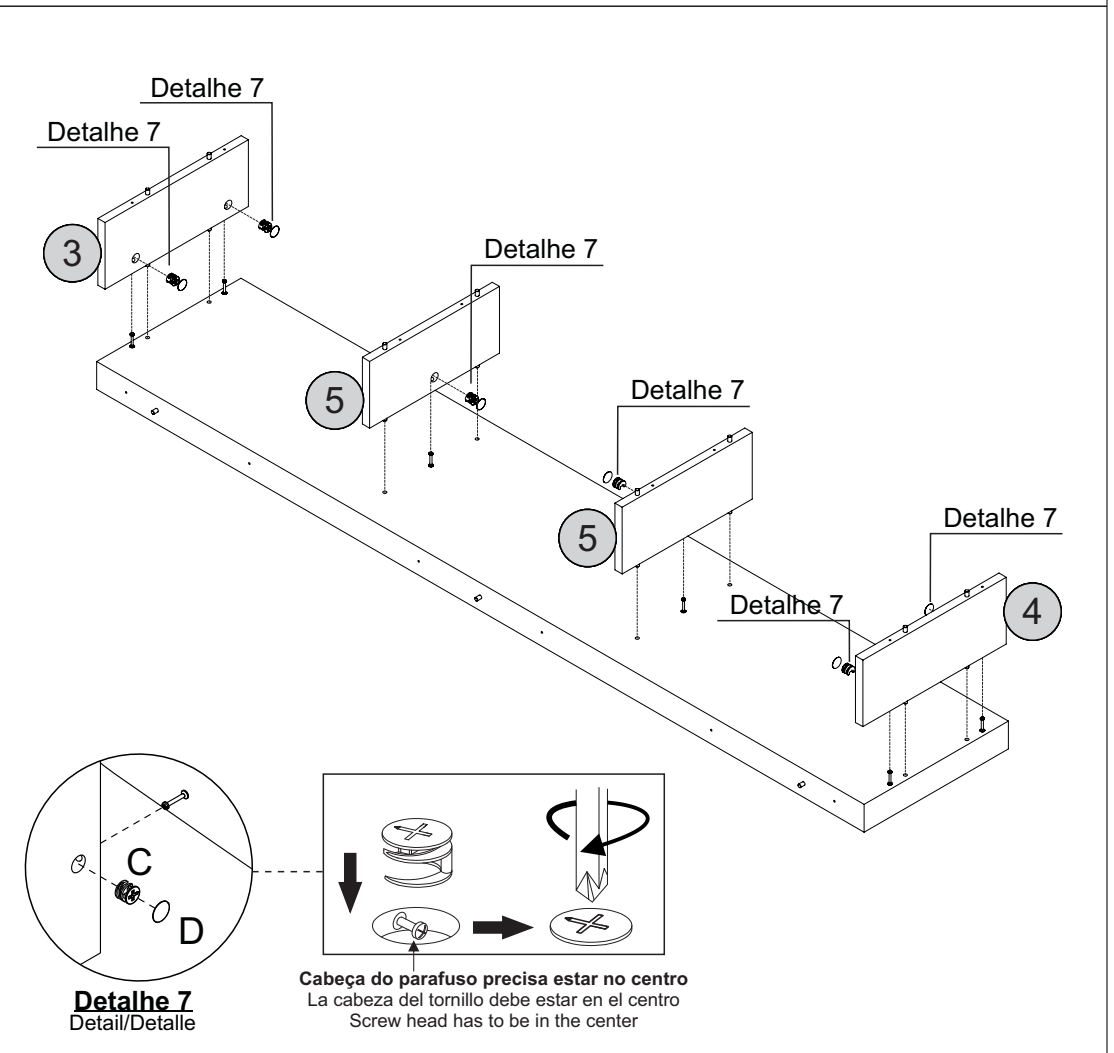
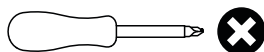

Detalhe 7
Detail/Detalle

Cabeça do parafuso precisa estar no centro
La cabeza del tornillo debe estar en el centro
Screw head has to be in the center

Passo 13

Paso/Step

PEÇA

Piece/Pieza

2 - BASE x1

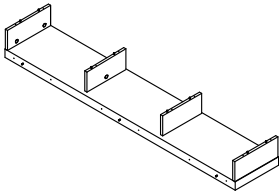

FERRAGEM

Hardware/Herraje

E  06

FERRAMENTA

Tool/Herramienta

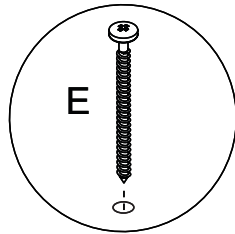
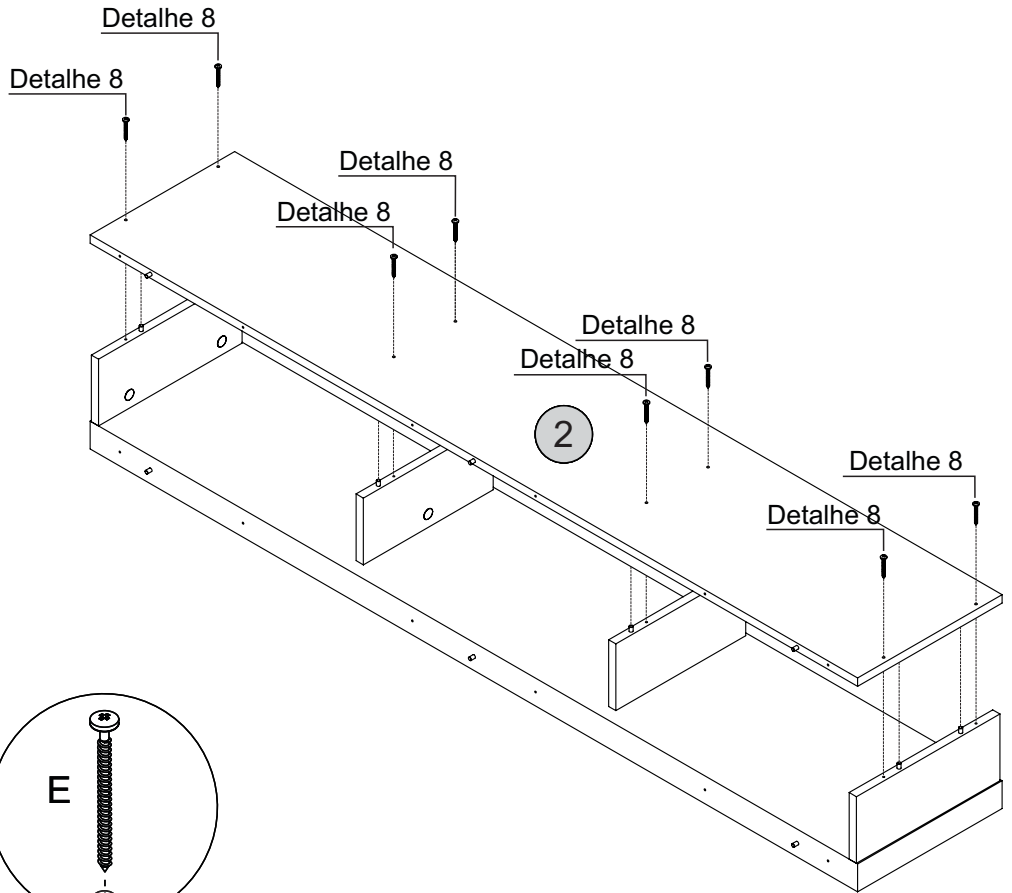
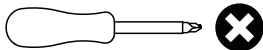

Detalhe 8
Detail/Detalle

Passo 14

Paso/Step

PEÇA

Piece/Pieza

9 - PAINEL TRAS. INFERIOR x1

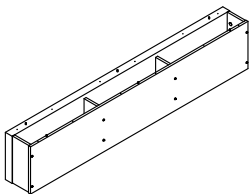

FERRAGEM

Hardware/Herraje

E  x12

FERRAMENTA

Tool/Herramienta

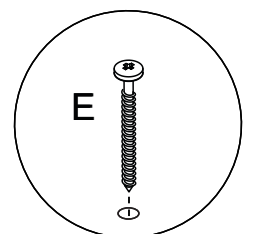
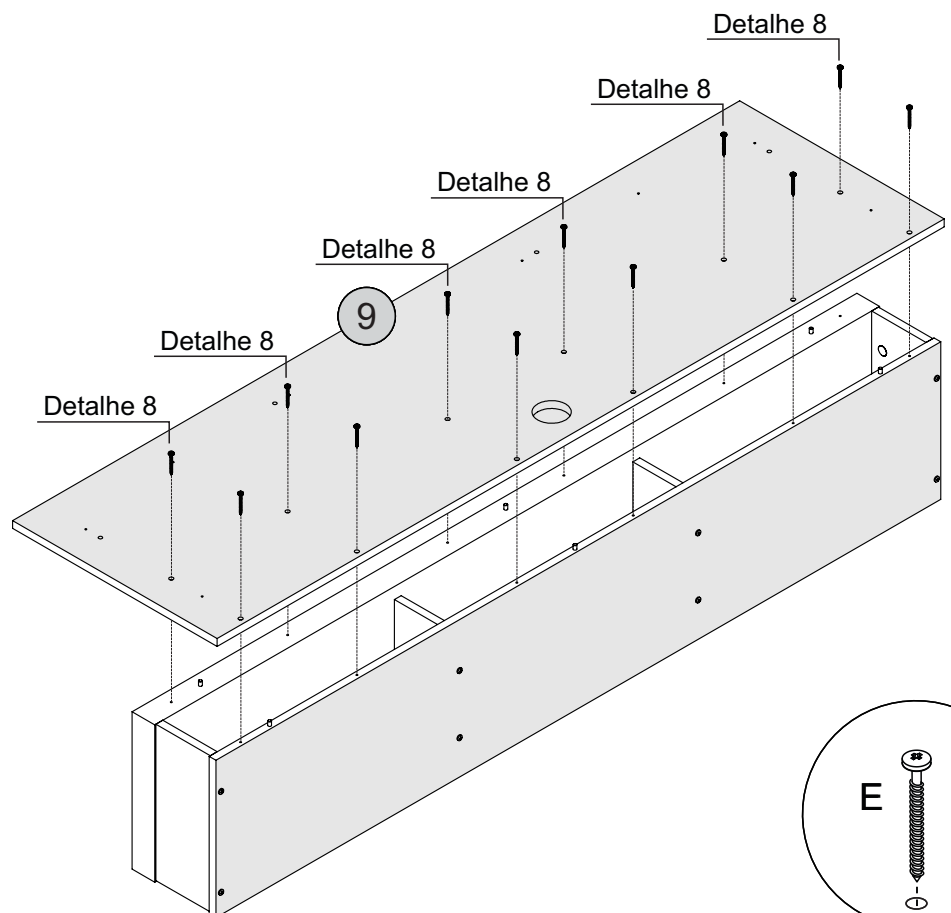
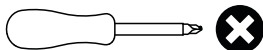

Detalhe 8
Detail/Detalle

Passo 15

Paso/Step

PEÇA
Piece/Pieza

14 - TRAVESSA MAIOR x1

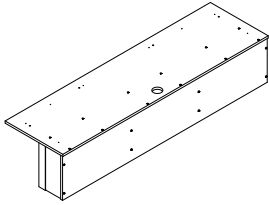

FERRAGEM
Hardware/Herraje

G  x8

FERRAMENTA
Tool/Herramienta

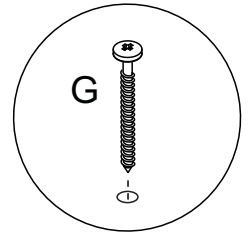
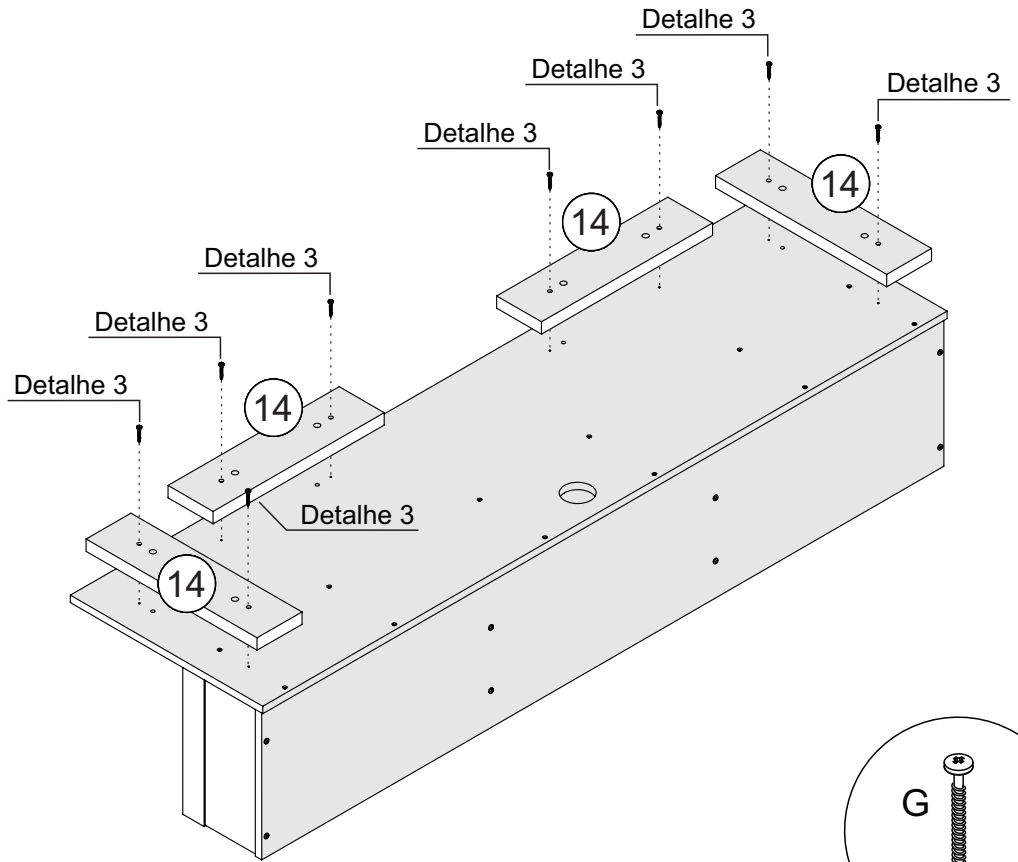
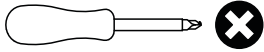

Detalhe 3
Detail/Detalle

Passo 16

Paso/Step

PEÇA
Piece/Pieza

15 - TRAVESSA MENOR x2

FERRAGEM
Hardware/Herraje

G  x8

FERRAMENTA
Tool/Herramienta

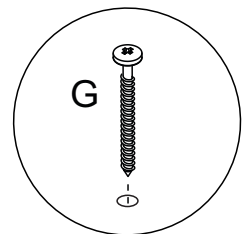
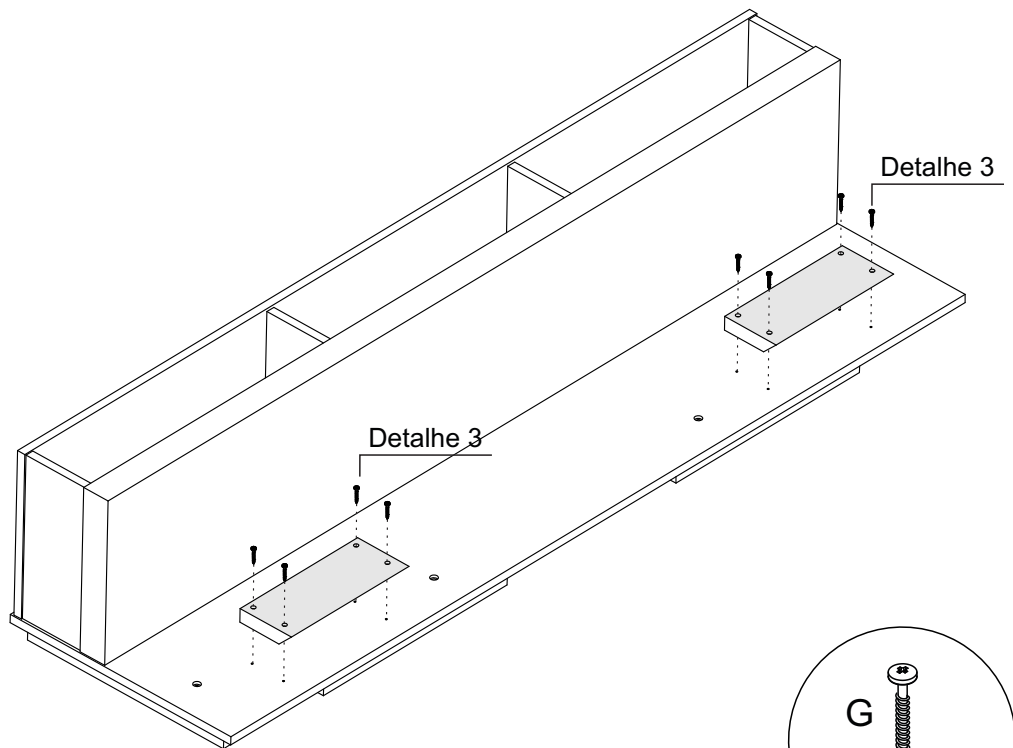
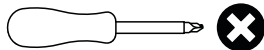

Detalhe 3
Detail/Detalle

Passo 17

Paso/Step

PEÇA
Piece/Pieza

10 - PAINEL TRAS. SUPERIOR x1

14 - TRAVESSA MAIOR x1

FERRAGEM
Hardware/Herraje

G  x8

FERRAMENTA
Tool/Herramienta

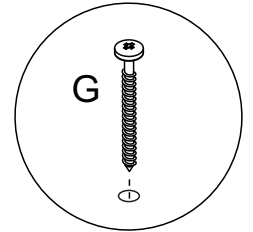
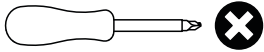

Detalhe 3
Detail/Detalle

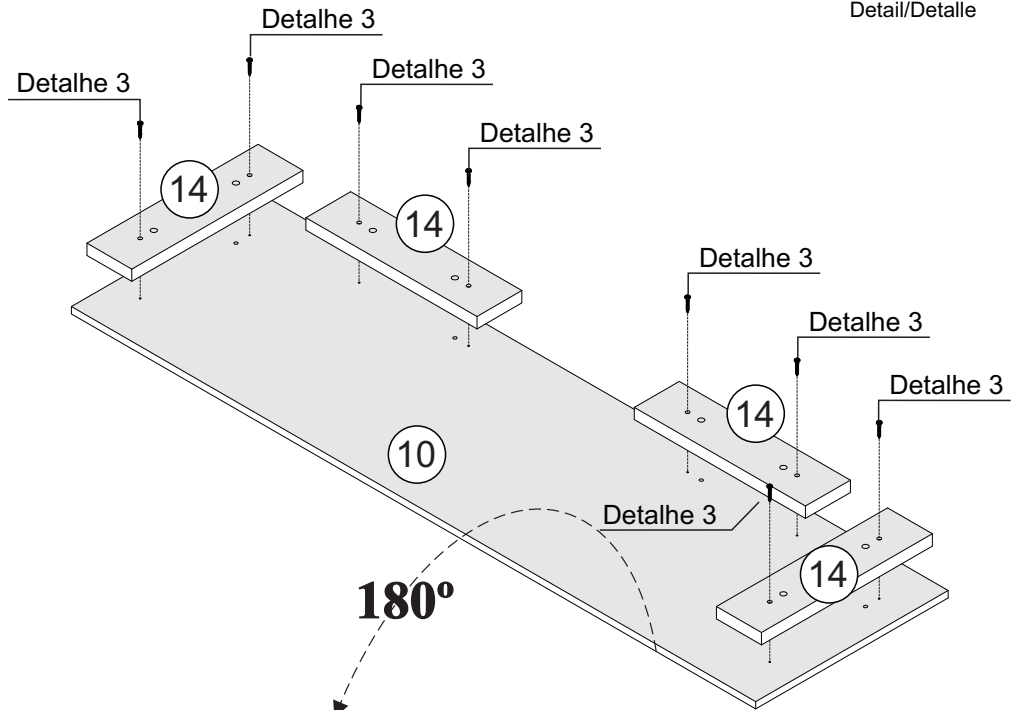

Passo 18

Paso/Step

PEÇA
Piece/Pieza

15 - TRAVESSA MENOR x2

FERRAGEM
Hardware/Herraje

G  x8

FERRAMENTA
Tool/Herramienta

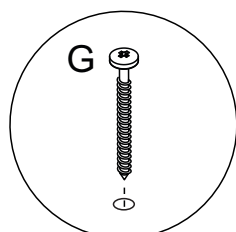
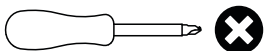

Detalhe 3
Detail/Detalle

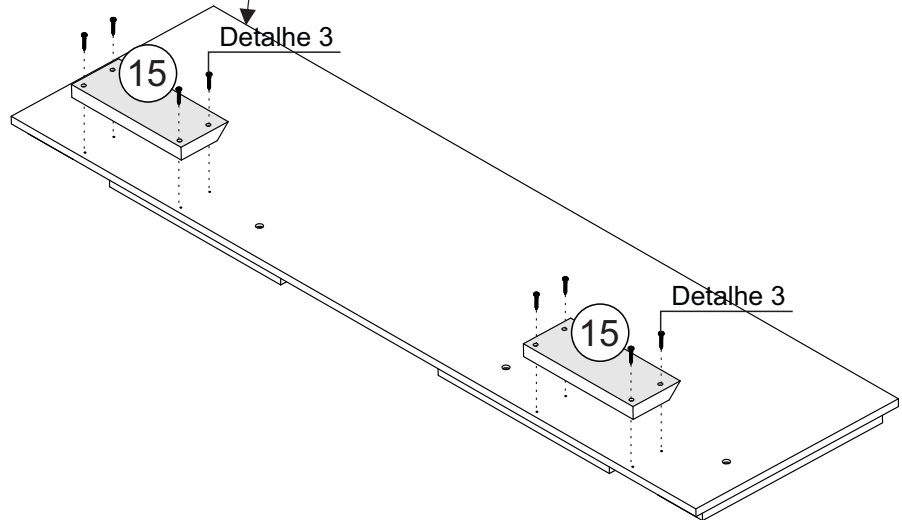

Passo 19

Paso/Step

PEÇA
Piece/Pieza

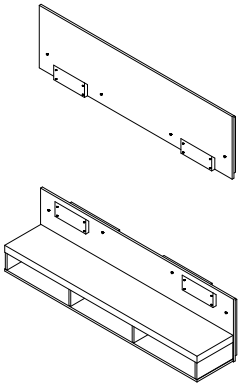

FERRAGEM
Hardware/Herraje

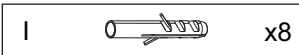
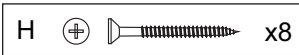

FERRAMENTA
Tool/Herramienta

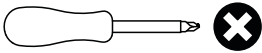

Esquema de furação da parede / Esquema de perforación de la pared / Wall drilling Scheme

-8 furos com broca Ø8mm.
-8 agujeros con taladro de 8mm.
-8 holes with 8mm drill.

PAREDE
pared
wall

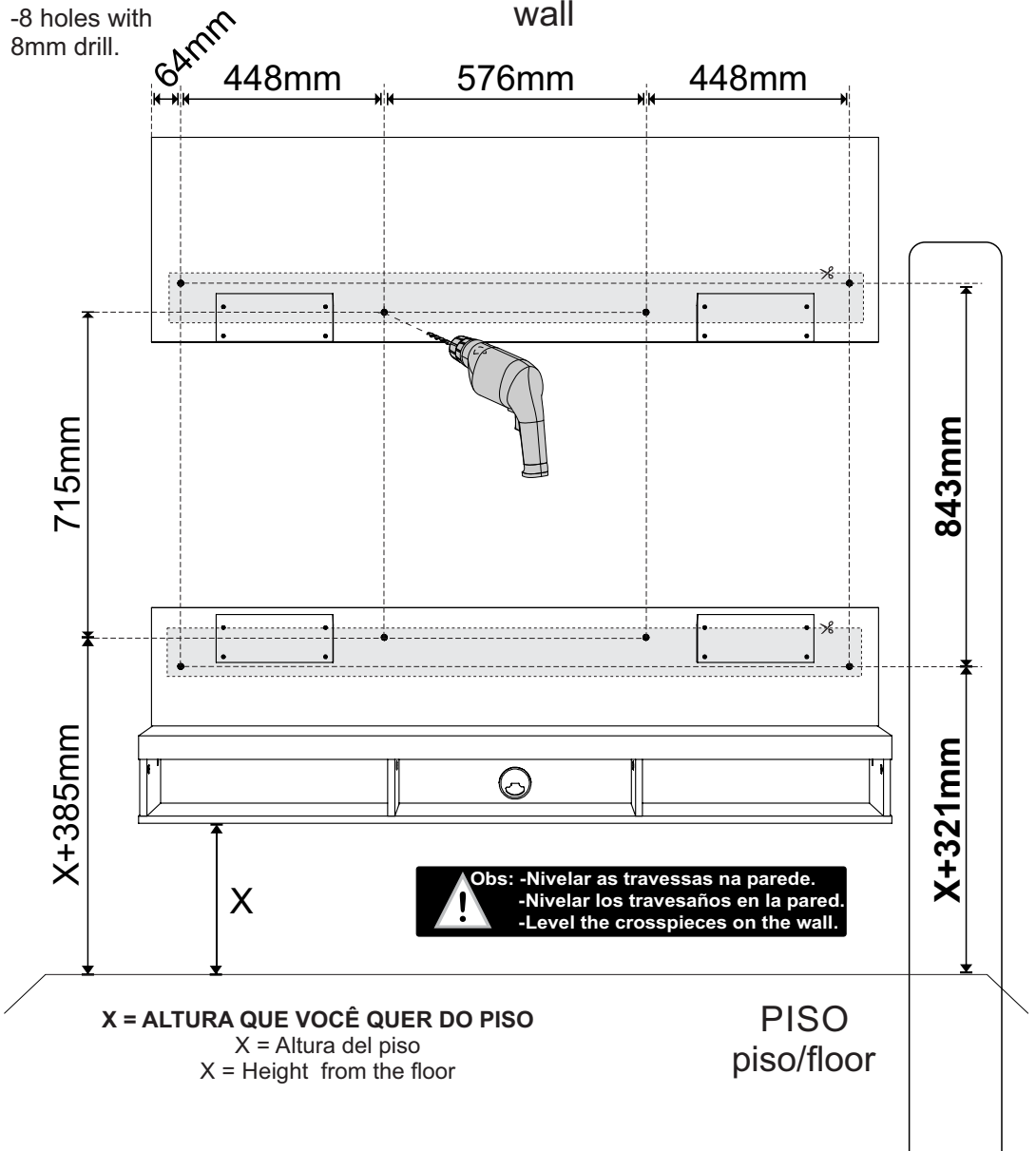

X = ALTURA QUE VOCÊ QUER DO PISO
X = Altura del piso
X = Height from the floor

PISO
piso/floor

Ex: Se você quer que o painel fique a 500mm do piso:

Altura do primeiro furo = 500+321=821mm

Altura do segundo furo = 821+843=1664mm.

Ejemplo:

Si desea que el panel esté a 500 mm del piso:

Altura del primer agujero= 500+321=821mm

Altura del segundo agujero= 821+843=1664mm.

Example:

If you want the panel to be 500mm from the floor:

Height of the first hole line = 500+321=821mm

Height of second hole line = 821+843=1664mm.

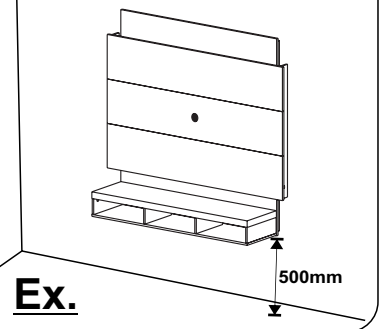

Fixar o gabarito na parede com fita.

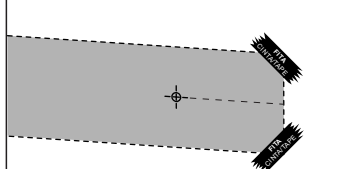

Put the template on the wall with tape.
Fije la plantilla a la pared con cinta adhesiva.

Furar a parede conforme o gabarito.

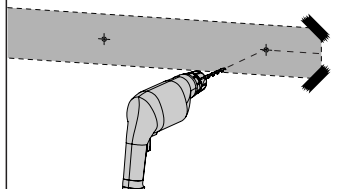

Drill the wall according to the template.
Taladre la pared de acuerdo con la plantilla.

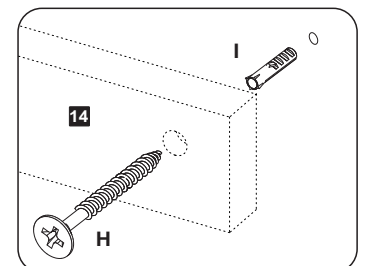

Passo 20

Paso/Step

PEÇA
Piece/Pieza

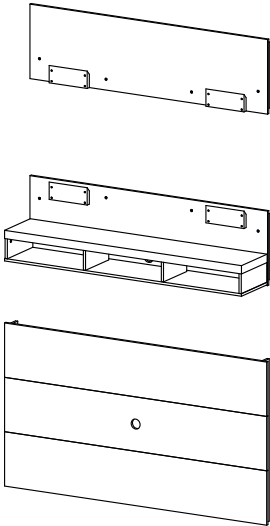

FERRAGEM
Hardware/Herraje



FERRAMENTA
Tool/Herramienta

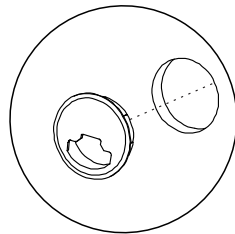

Detalhe 9
Detail/Detalle

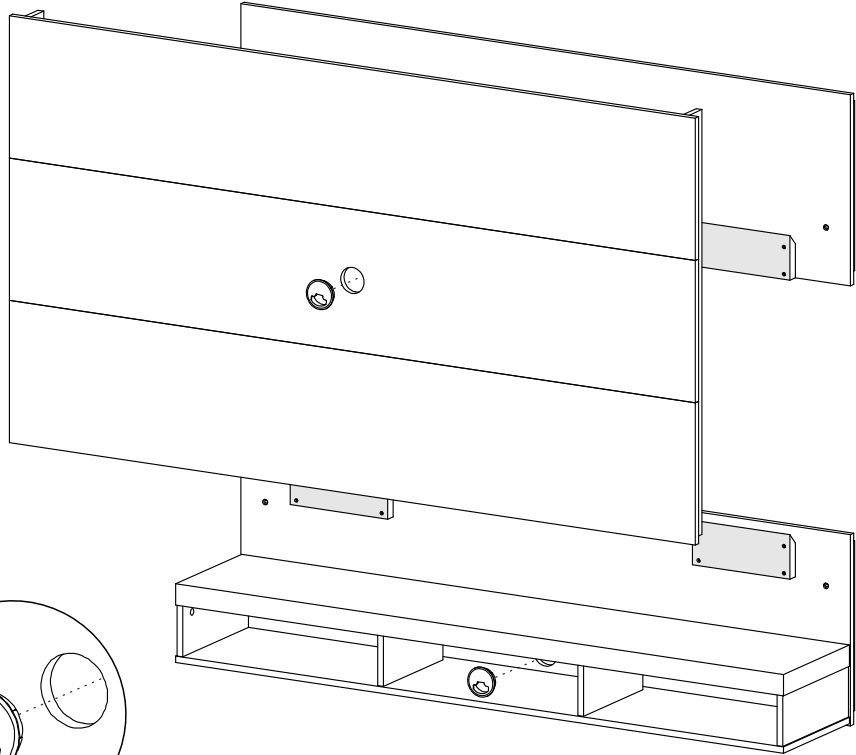

Passo 21

Paso/Step

PEÇA
Piece/Pieza

FERRAGEM
Hardware/Herraje

FERRAMENTA
Tool/Herramienta

	kit suporte TV			
M	 M1 35x77mm	 M2 48x28mm	 M3 100x56mm	2
M6	 M6	 Parafuso M6 x 16		4
M7	 M7	 Parafuso M8 x 16		4



-Para facilitar a fixação do Suporte Universal, enviamos 2 modelos de parafusos que estão de acordo com os padrões mais usados pelos principais fabricantes de TVs LCD / LED / PLASMA / 3D do mercado. Caso nenhum dos 2 modelos se encaixe adequadamente ao seu televisor, adquira o parafuso compatível com sua TV em qualquer loja de ferragens. Para evitar danos à sua TV, não aperte demasiadamente os parafusos.

-Para facilitar la colocación del soporte universal, enviamos 2 modelos de tornillos que cumplen con los estándares más utilizados por los principales fabricantes de televisores. Si ninguno de los modelos se ajusta a su televisor correctamente, compre el tornillo compatible con su televisor en cualquier ferretería. Para evitar daños a su televisor, no apriete demasiado los tornillos.

-To make it easier to attach the TV support, we send 2 screw models that match the most commonly used TVs. If neither model fits your TV properly, purchase the compatible screw from any hardware store. To prevent damage to your TV, do not over tighten the screws.

Passo 22

Paso/Step

PEÇA
Piece/Pieza

FERRAGEM
Hardware/Herraje

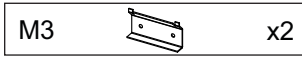
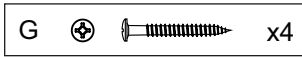

FERRAMENTA
Tool/Herramienta

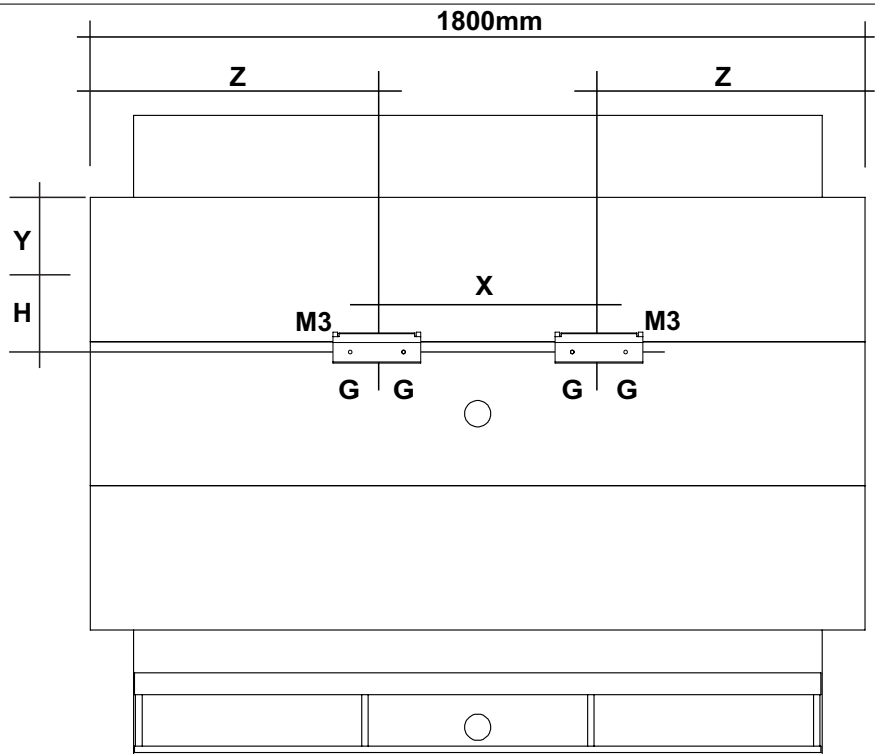
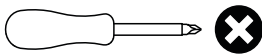

Y = Altura desejada para a TV.

Y = Useful height above the TV.

Y = Altura sobre el TV.

H = Distância dos furos da TV até a borda.

H = Distance from the TV holes to the TV border.

H = Distancia desde los orificios del TV hasta el borde del TV.

X = Distância entre os furos da sua TV.

X = Distance between the TV holes.

X = Distancia entre los orificios del TV.

Passo 23

Paso/Step

PEÇA
Piece/Pieza

FERRAGEM
Hardware/Herraje



FERRAMENTA
Tool/Herramienta

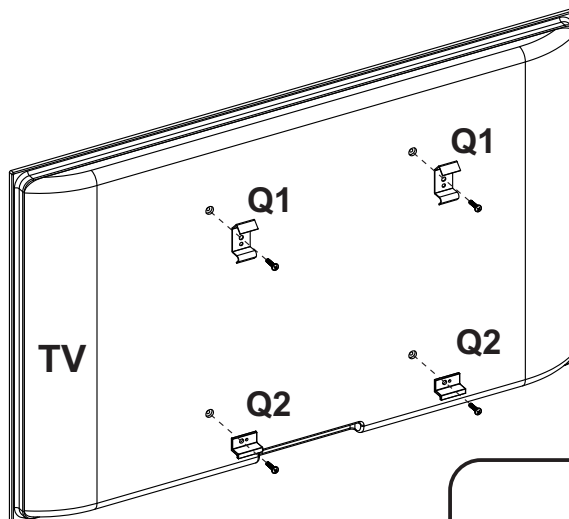
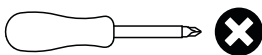

Suporte Superior

Soporte superior / Upper support

Utilizar o parafuso indicado no manual da TV Q6,Q7(VESA).

Use el tornillo indicado del televisor manual Q6,Q7(VESA).

Use the screw indicated the TV's manual Q6,Q7(VESA).

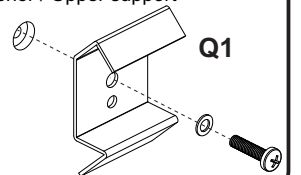

Suporte Inferior

Soporte inferior / Lower support

Utilizar o parafuso indicado no manual da TV Q6,Q7(VESA).

Use el tornillo indicado del televisor manual Q6,Q7(VESA).

Use the screw indicated the TV's manual Q6,Q7(VESA).

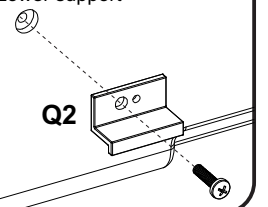

Passo 24

Paso/Step

PEÇA
Piece/Pieza

FERRAGEM
Hardware/Herraje

FERRAMENTA
Tool/Herramienta

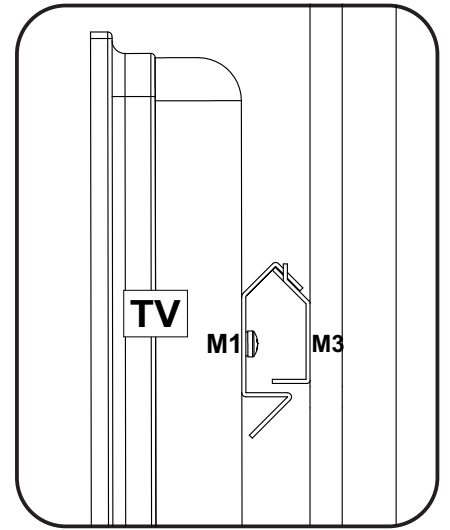
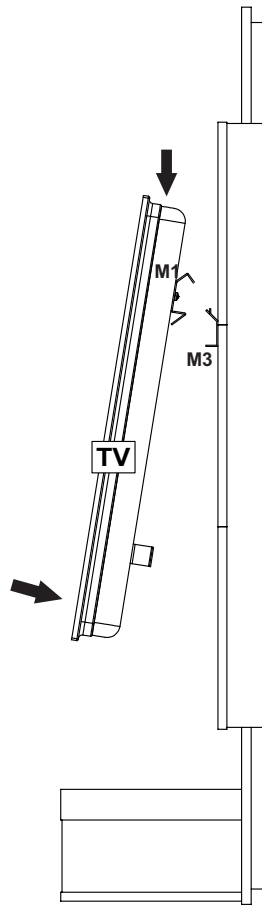

Passo 25

Paso/Step

PEÇA
Piece/Pieza

FERRAGEM
Hardware/Herraje

FERRAMENTA
Tool/Herramienta

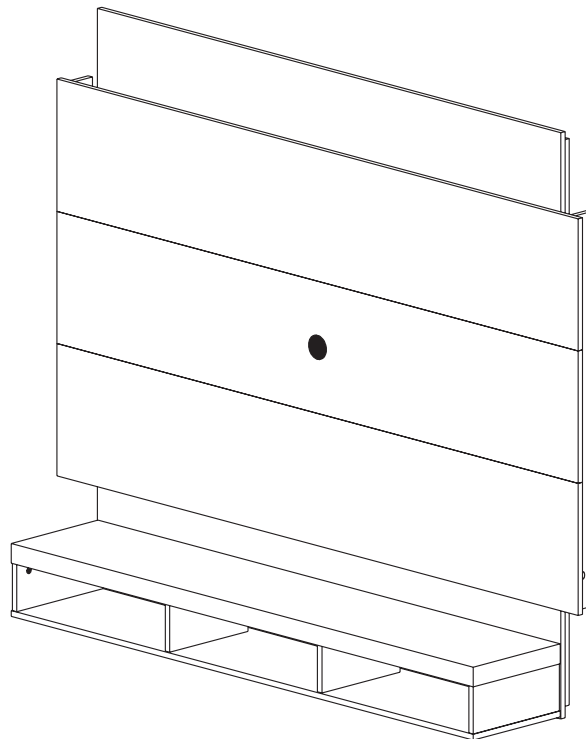



Parabéns, você montou seu móvel! Agora é só decorar sua casa e aproveitar!

Queremos ver como ficou o móvel Artely do seu jeito... Marque a gente com a #meuartely. Ficaremos felizes em compartilhar!

Ah, e se tiver qualquer dúvida, sugestão ou comentário, entra em contato com a gente pelo nosso site www.artely.com.br.

¡Congratulaciones, montaste tu mueble! ¡Ahora solo decora tu casa y disfruta!

Queremos ver este producto en tu hogar, a tu manera... Utilice #meuartely, ¡ficaremos encantados de compartir tu foto!

Si tienes alguna duda, sugerencia o comentario, contáctenos a través de nuestro sitio web www.artely.com.br.

Congratulations, you've assembled your new furniture! Decorate your home and enjoy!

We want to see how this product is in your home... Use #meuartely, we will be happy to share your picture!

If you have any doubt, suggestion or comment, get in touch with us through our website www.artely.com.br.

