

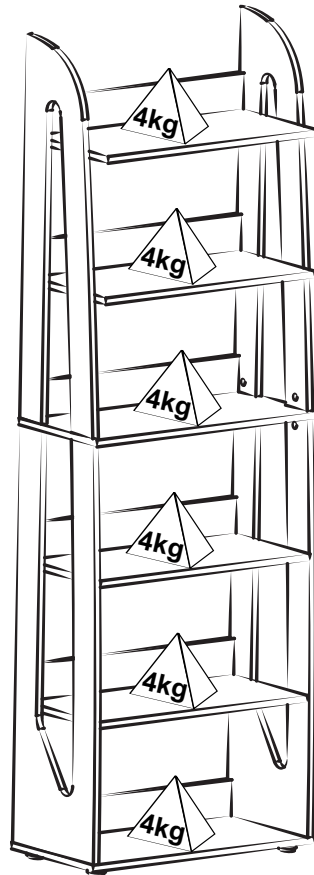

Estante Floripa II

Estante Floripa II / Floripa II Bookcase

Versão 1.0 / Versión 1.0 / 1.0 Version

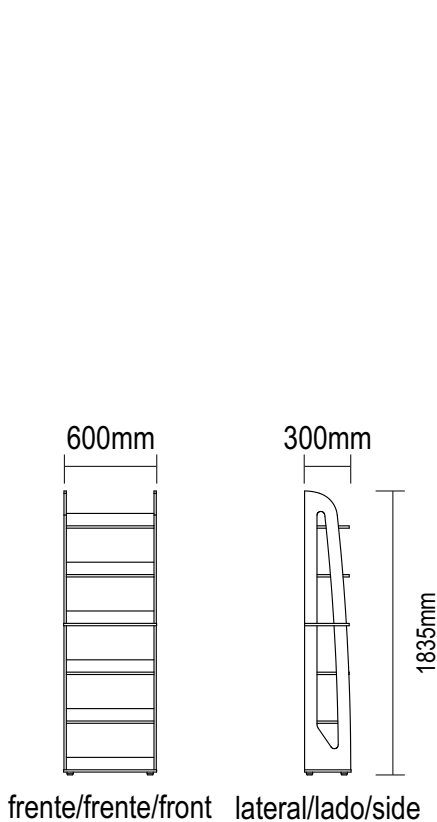

Assista ao vídeo de montagem
Asista al video de montaje
Watch the assembly video

Conservação e Limpeza - Conservación y Limpieza - Conservation and Cleaning

Não expor o produto ao sol, altas temperaturas e umidade. Não arrastar objetos sobre a superfície do móvel (ex.: TV, DVD, aparelho de som, objetos decorativos...) e manter em local seco e arejado. Para a limpeza, utilizar um pano seco e macio. Não é necessário o uso de materiais abrasivos ou álcool.

No exponga el producto a la luz solar, las altas temperaturas y la humedad. No arrastre los objetos a través de la superficie de la unidad (por ejemplo, TV, DVD, equipo de música, objetos de decoración ...) Mantener en un lugar fresco y seco. Para la limpieza, utilizar un paño seco y suave. El uso de materiales abrasivos o del alcohol no es necesario.

Do not expose the product to sunlight, high temperatures and humidity. Do not drag objects across the surface of the unit (TV, DVD, stereo, decorative objects ...) keep it in a cool dry place. For cleaning, use a dry and soft cloth. Do not use abrasive materials or alcohol.

Garantia

Este certificado de Garantia é uma vantagem adicional oferecida ao consumidor, porém para que o mesmo tenha validade é imprescindível que seja apresentada a NOTA FISCAL de compra do produto.

Com este produto, a **Artely** tem como objetivo atender plenamente o proprietário-consumidor, proporcionando a garantia na forma aqui estabelecida, pelo período de três meses a partir da data da nota fiscal de compra. A **Artely** restringe a sua responsabilidade à substituição gratuita das peças defeituosas, em caso de defeitos ou avarias devidamente constatados como sendo de fabricação, durante a vigência desta garantia.

A **Artely** declara a garantia nula e sem efeito se o produto for alterado, adulterado, molhado ou consertado e ainda pela prática de montagem inadequada ou mau uso. Também será considerada nula em casos de força maior, como aqueles causados por agentes da Natureza (chuvas, incêndios, excesso de umidade, cupins,...) e eventos externos como objetos arrastados sobre a superfície do móvel (ex.: TV, DVD, aparelho de som, objetos decorativos...).

Para exercer seus direitos de comprador é importante que antes de montar seu produto você leia com atenção as instruções de cada passo do manual de montagem que acompanha o móvel.

Caso o produto não esteja em conformidade, entre em contato com a loja onde efetuou a compra e faça sua reclamação, apontando os defeitos técnicos observados. Para agilizar o seu atendimento, tenha sempre em mãos o manual de montagem com os respectivos números das peças defeituosas, conforme descritas no manual.

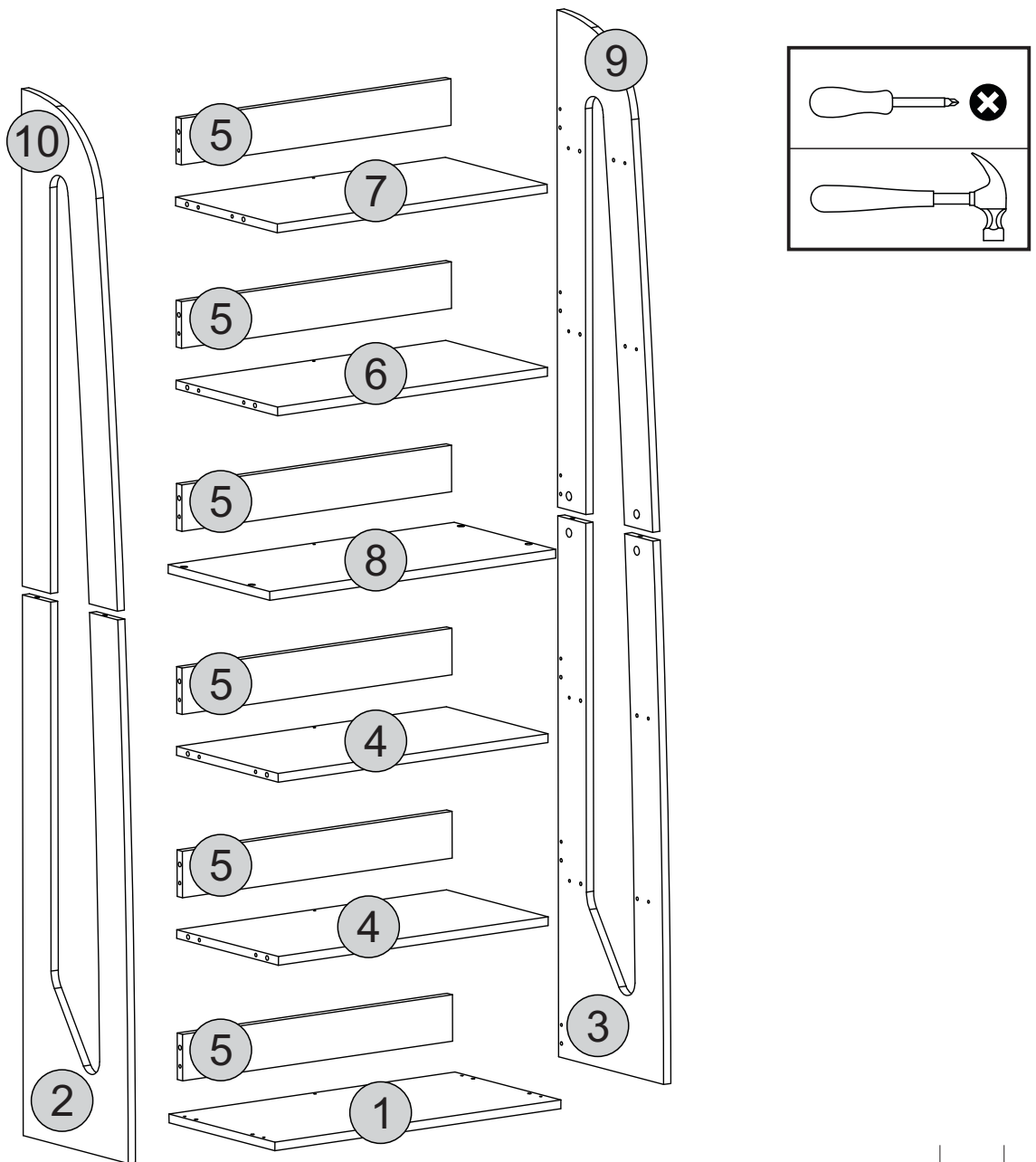

Descrição

- 1-Base (600x300x15mm)
- 2-Lateral esquerda inf. (930x298x15mm)
- 3-Lateral direita inf. (930x298x15mm)
- 4-Prateleira (566x288x15mm)
- 5-Travessa (566x80x15mm)
- 6-Prateleira int. (566x288x15mm)
- 7-Prateleira sup. (566x288x15mm)
- 8-Divisão (600x288x15mm)
- 9-Lateral direita sup. (855x269x15mm)
- 10-Lateral esquerda sup. (855x269x15mm)

Descripción

- 1-Base
- 2-Lateral izquierda inferior
- 3-Lateral derecha inferior
- 4- Anaquel
- 5-Travesaño
- 6-Anaquele intermediario
- 7-Anaquele superior
- 8-División
- 9-Lateral derecha superior
- 10-Lateral izquierda superior

Description

- 1-Base
- 2-Lower left side
- 3-Lower right side
- 4-Shelf
- 5-Crosspiece
- 6-Intermediary shelf
- 7-Upper shelf
- 8-Partition
- 9-Upper right side
- 10-Upper left side

Qty

- 1
- 1
- 1
- 2
- 6
- 1
- 1
- 1
- 1
- 1





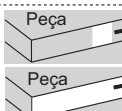

- O número na borda da peça corresponde ao manual.
- Para retirada do número usar Lustra-Móveis, Álcool em Gel ou Borracha.
- El número en el borde de la pieza coincide con el manual.
- Use una goma de borrar blanca, alcohol en gel o lustrador para muebles para eliminar los números.
- The number on the edge of the piece matches the manual.
- Use a White eraser, Alcohol Gel or Furniture Polish to remove the numbers.

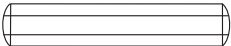
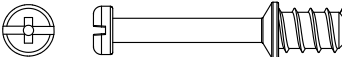
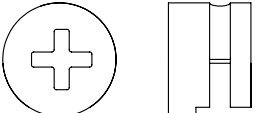

- Cor da Borda **Azul** (Lateral direita) **Azul** (Lateral derecha) **Blue** (Right side)
- Color del borde **Vermelho** (Lateral esquerda) **Rojo** (Lateral izquierda) **Red** (Left side)
- Edge color **Preto** (Divisão direita) **Negro** (División derecha) **Black** (Right partition)
- Verde** (Divisão esquerda) **Verde** (División izquierda) **Green** (Left partition)

Lista de Materiais Lista de Materiales/ Hardware List

A		Cavilha / Tarugo / Dowel Ø6x30mm	32
B		Minifix / Minifix / Minifix Ø7x30mm	28
C		Tambor / Tambor / Minifix Cam Ø15x12mm	36
D		Tapa furo adesivo / Adhesivo / Hole Cover Ø18mm	36
E		Parafuso Tornillo / Screw Ø3,5x40mm CP	10
F		Sapata / Pata / Foot Ø40x26mm	04
G		Haste Dupla Minifix / Minifix Doble Varilla / Double Rod Minifix Ø7x60mm	04

DICAS PARA FIXAR MINIFIX

TIP TO FASTEN THE MINIFIX
PISTA PARA ARREGLAR EL MINIFIX

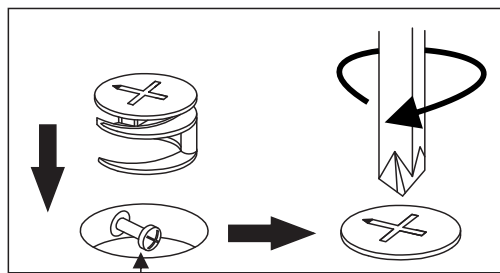

Cabeça do parafuso precisa estar no centro
La cabeza del tornillo debe estar en el centro
Screw head has to be in the center

Parafuso Minifix

Tornillo minifix/Minifix screw

Fixe o parafuso até o ressalto encostar na superfície da peça (veja o exemplo abaixo).

Tighten the screw until its overhang part lean on the piece surface (see the example below).

Fije el tornillo hasta que su parte sobressaliente toque la superficie de la pieza (vea el ejemplo abajo).

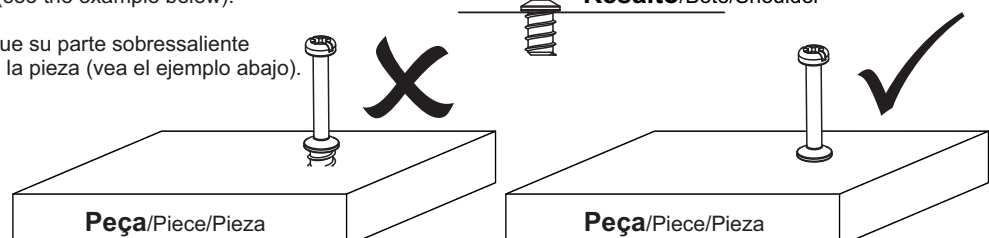

Passo 1

Paso/Step

PEÇA

Piece/Pieza

1 - BASE x1

FERRAGEM

Hardware/Herraje

F  04

FERRAMENTA

Tool/Herramienta

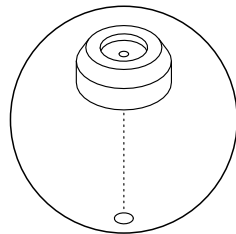
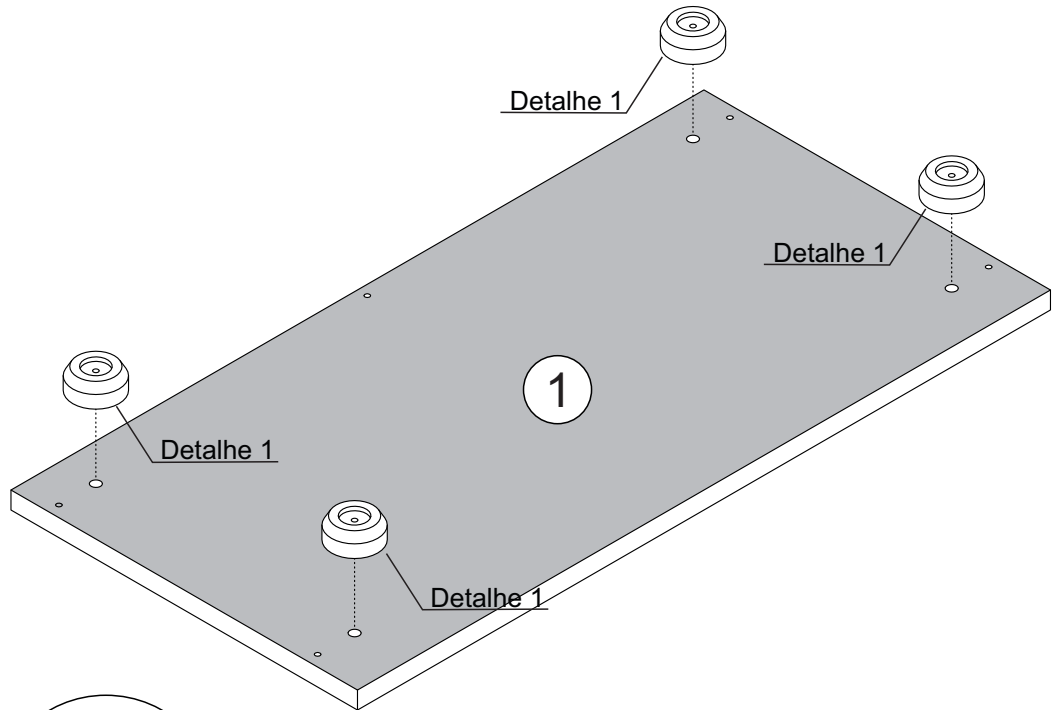
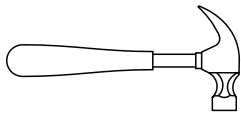

Detalhe 1
Detail/Detalle

Passo 2

Paso/Step

PEÇA

Piece/Pieza

4 - PRATELEIRA x2

5 - TRAVESSA x6

FERRAGEM

Hardware/Herraje

A  20

FERRAMENTA

Tool/Herramienta

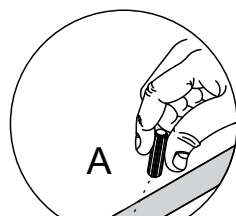
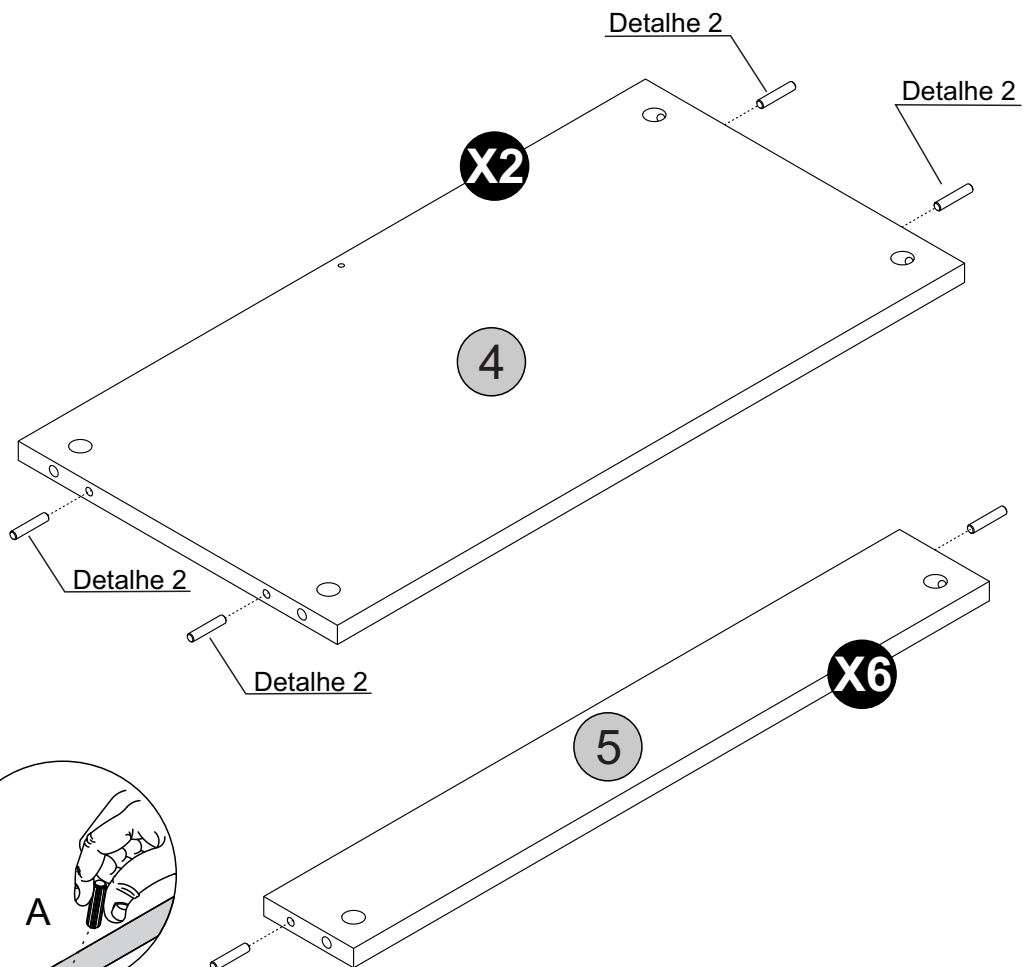
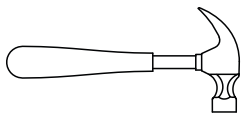

Detalhe 2
Detail/Detalle

Passo 3

Paso/Step

PEÇA

Piece/Pieza

6 - PRATELEIRA INT. x1

FERRAGEM

Hardware/Herraje

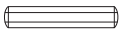
A  04

FERRAMENTA

Tool/Herramienta

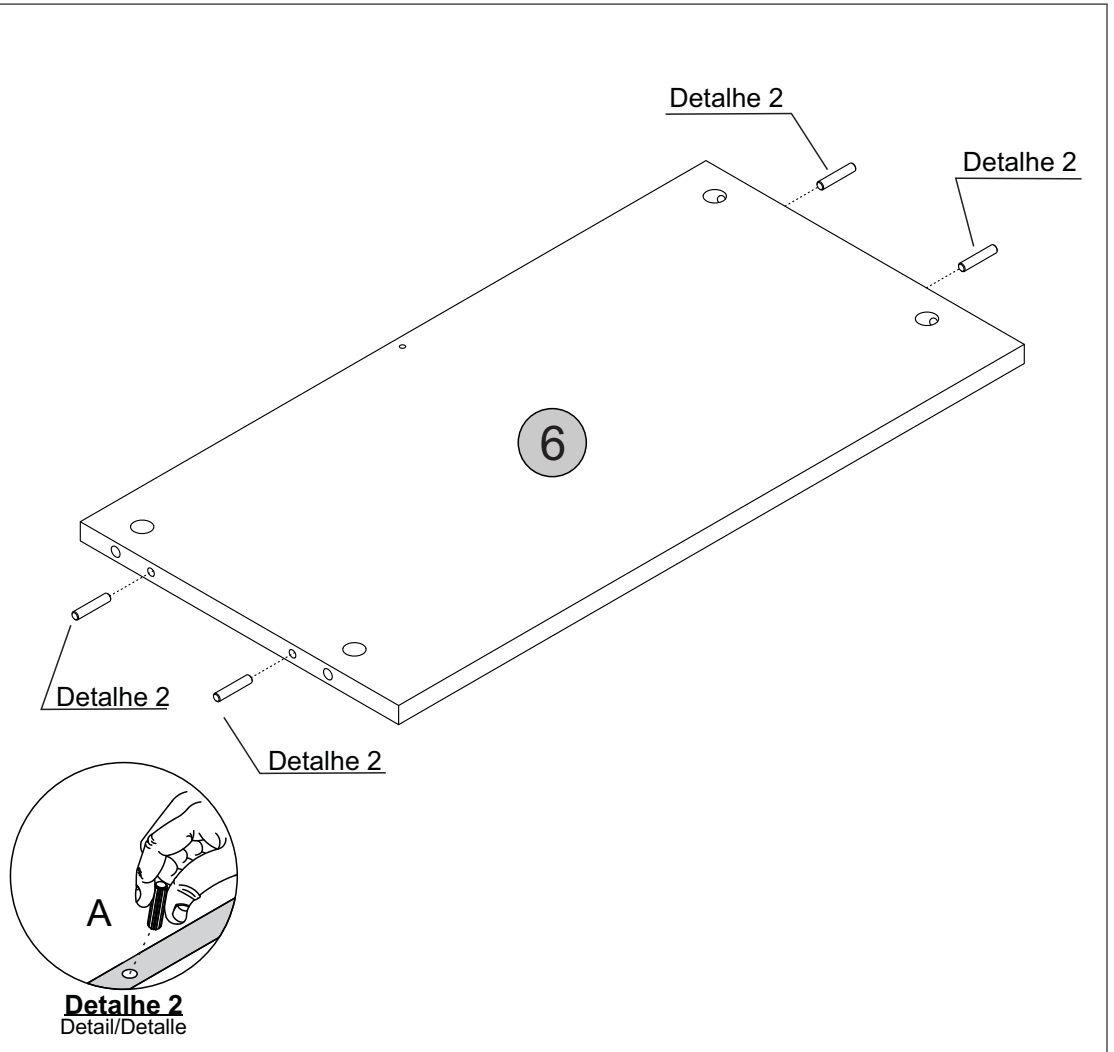
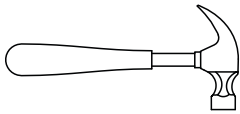

Passo 4

Paso/Step

PEÇA

Piece/Pieza

7 - PRATELEIRA SUP. x1

FERRAGEM

Hardware/Herraje

A  04

FERRAMENTA

Tool/Herramienta

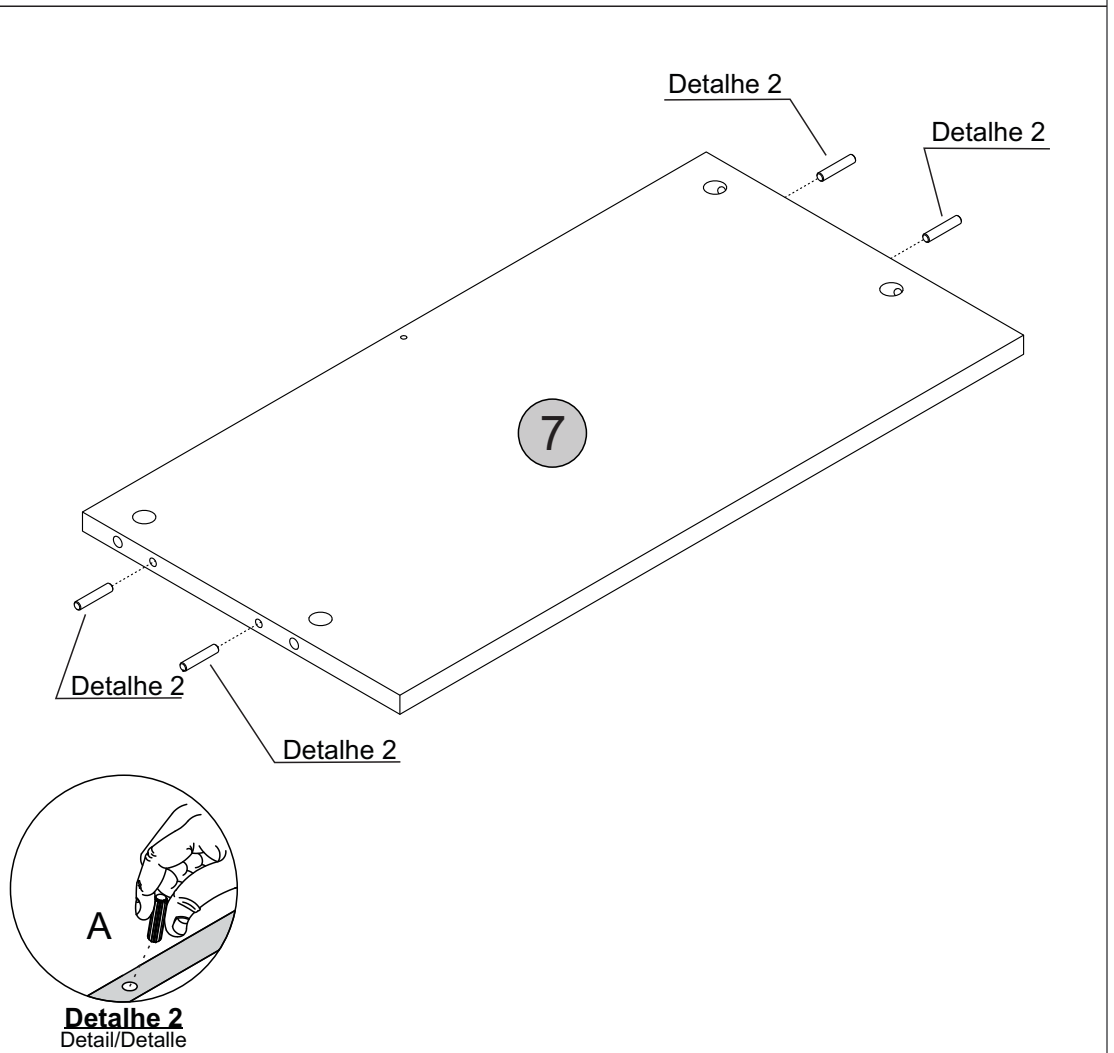
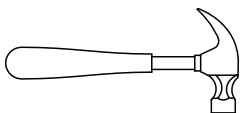

Passo 5

Paso/Step

PEÇA
Piece/Pieza

2 - LATERAL ESQ. INF. x1

10 - LATERAL ESQ. SUP. x1

FERRAGEM
Hardware/Herraje

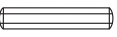
A  02

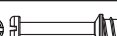
B  14

FERRAMENTA
Tool/Herramienta

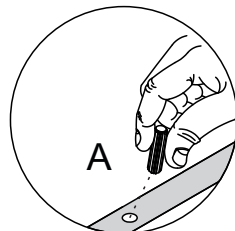
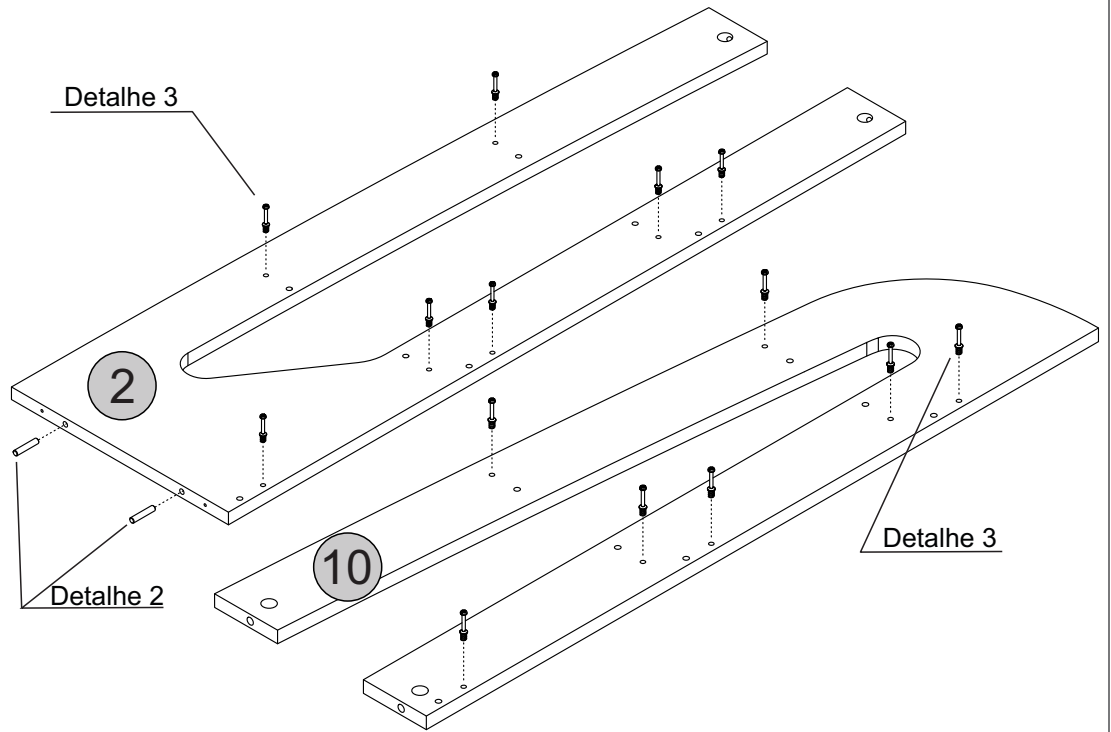
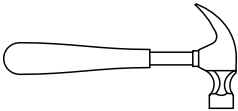
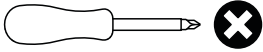

Detalhe 2
Detail/Detalle

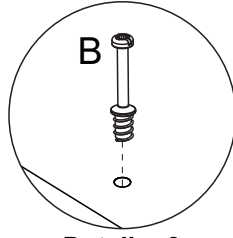

Detalhe 3
Detail/Detalle

Passo 6

Paso/Step

PEÇA
Piece/Pieza

3 - LATERAL DIR. INF. x1

9 - LATERAL DIR. SUP. x1

FERRAGEM
Hardware/Herraje

A  02

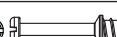
B  14

FERRAMENTA
Tool/Herramienta

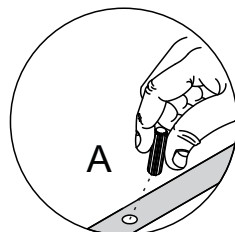
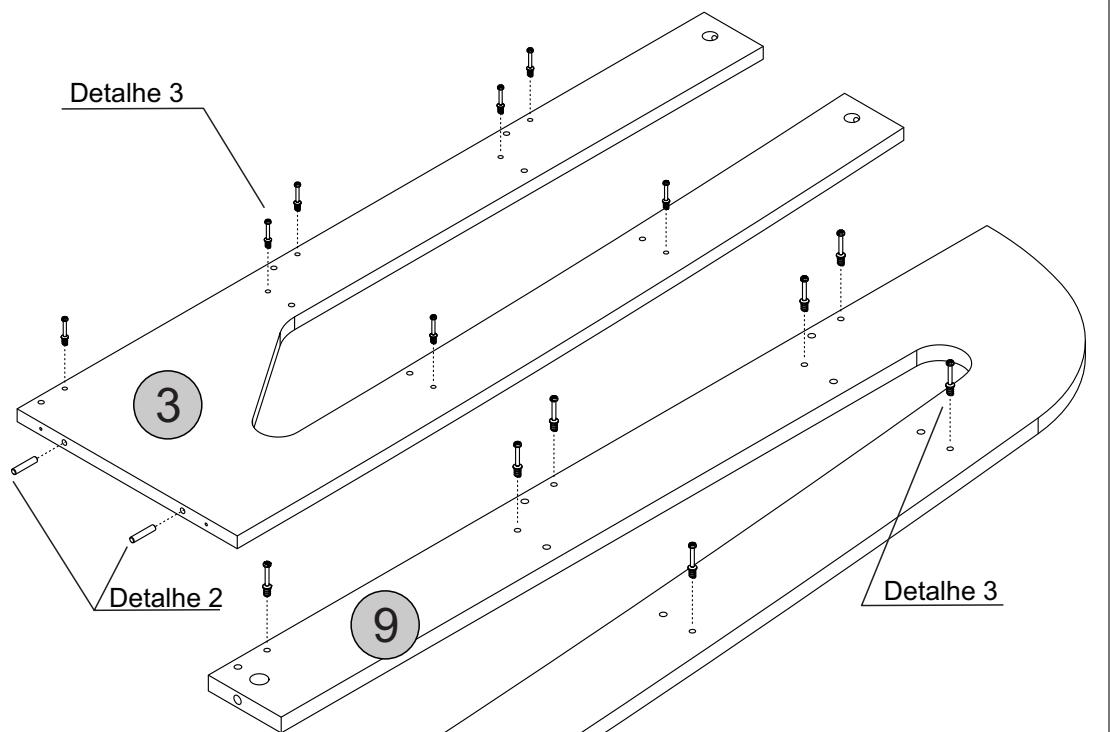
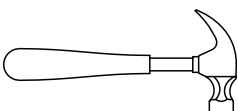
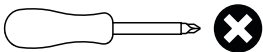

Detalhe 2
Detail/Detalle

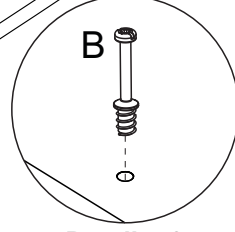

Detalhe 3
Detail/Detalle

Passo 7

Paso/Step

PEÇA

Piece/Pieza

2 - LATERAL ESQ. INF. x1

4 - PRATELEIRA x1

5 - TRAVESSA x1

FERRAGEM

Hardware/Herraje

C  03

D  03

FERRAMENTA

Tool/Herramienta

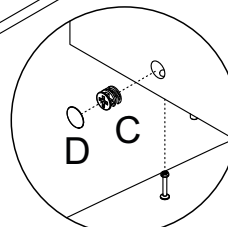
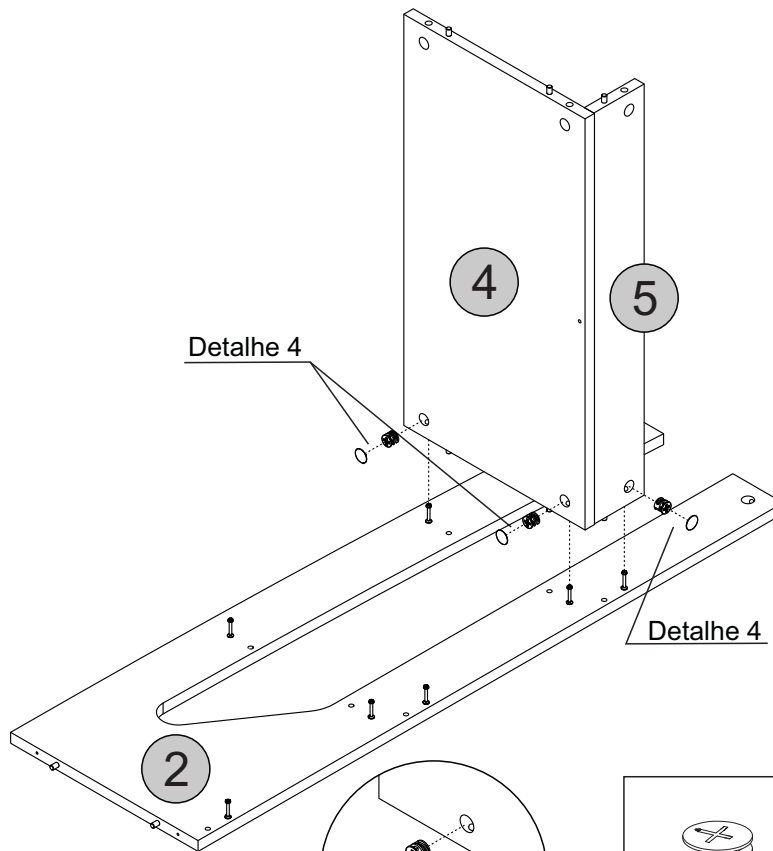
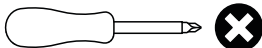

Detalhe 4
Detail/Detalle

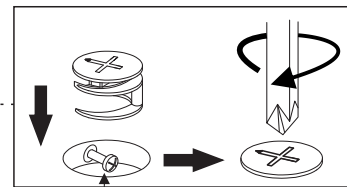

Cabeça do parafuso precisa estar no centro
La cabeza del tornillo debe estar en el centro
Screw head has to be in the center

Passo 8

Paso/Step

PEÇA

Piece/Pieza

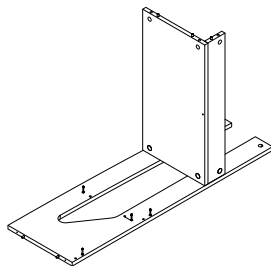

FERRAGEM

Hardware/Herraje

E  01

FERRAMENTA

Tool/Herramienta

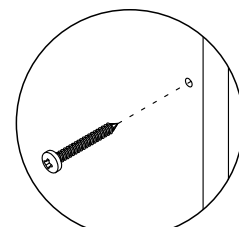
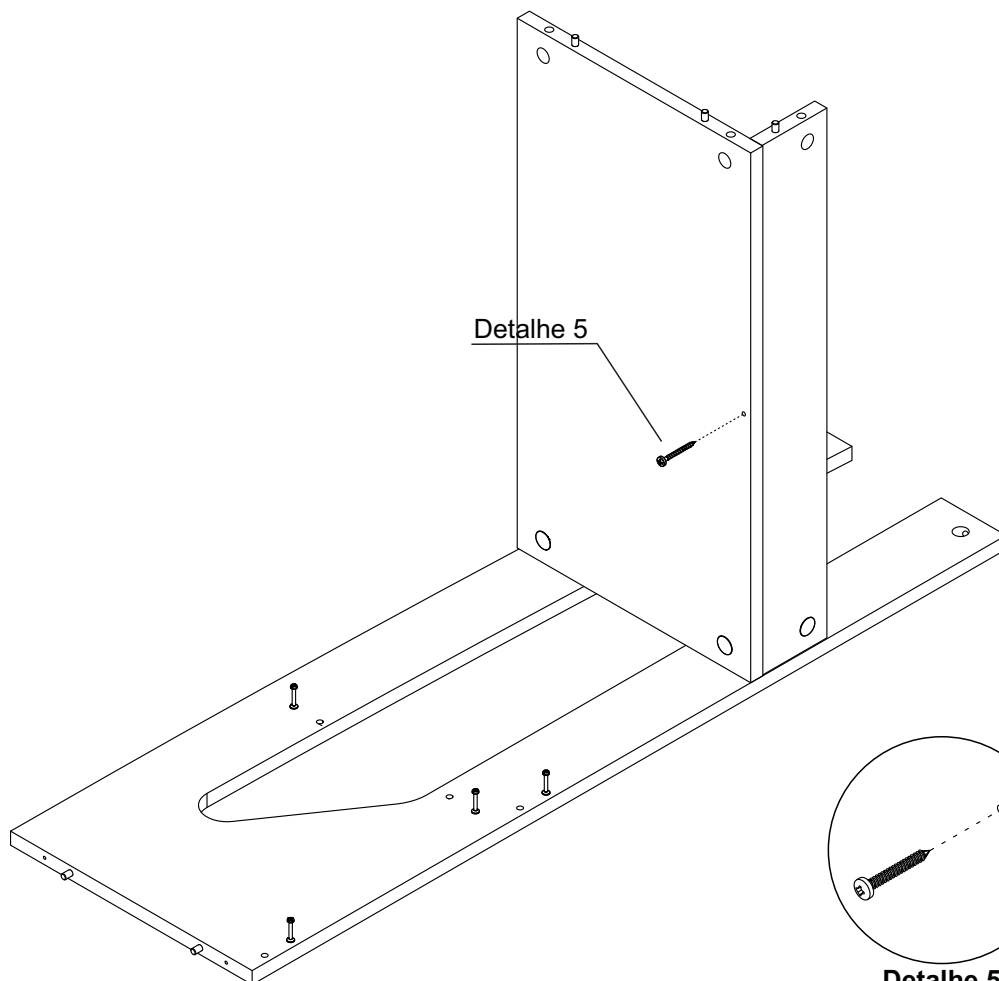
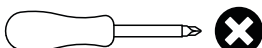

Detalhe 5
Detail/Detalle

Passo 9

Paso/Step

PEÇA

Piece/Pieza

4 - PRATELEIRA x1

5 - TRAVESSA x2

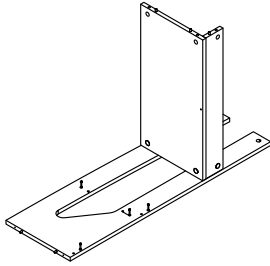

FERRAGEM

Hardware/Herraje

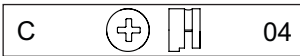

FERRAMENTA

Tool/Herramienta

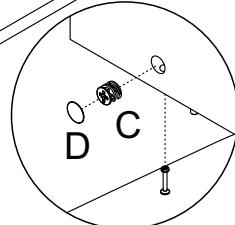
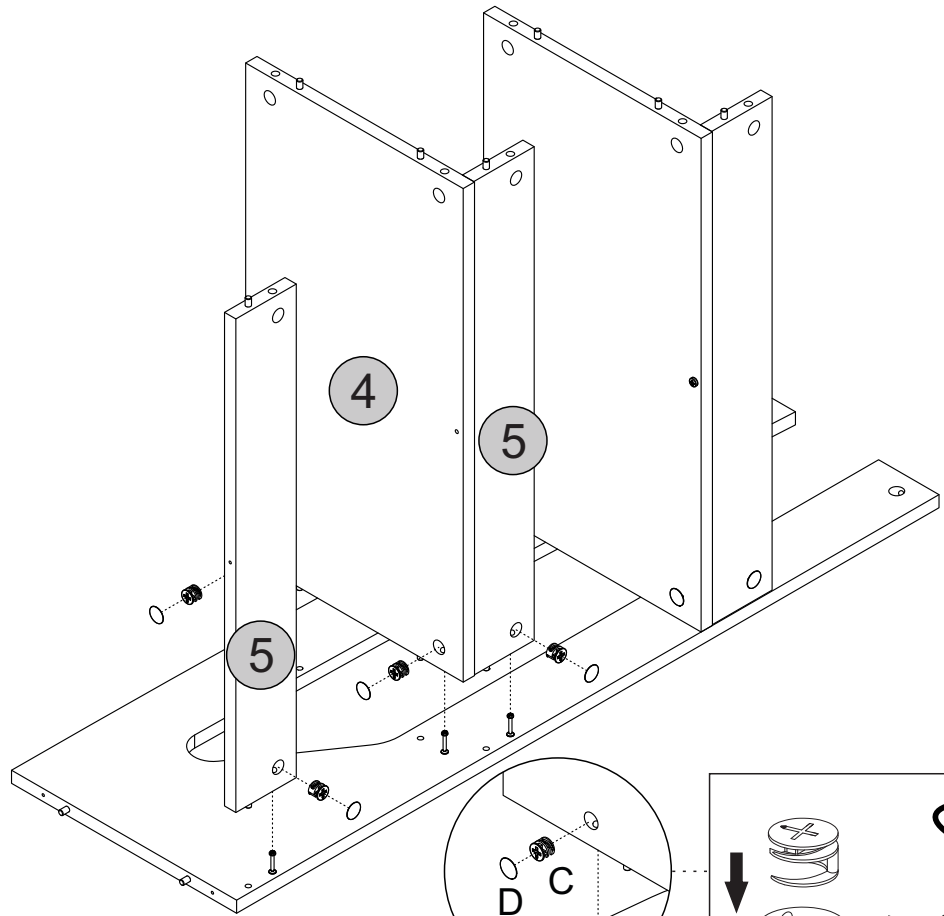
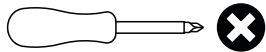

Detalhe 4
Detail/Detalle

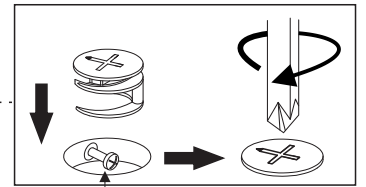

Cabeça do parafuso precisa estar no centro
La cabeza del tornillo debe estar en el centro
Screw head has to be in the center

Passo 10

Paso/Step

PEÇA

Piece/Pieza

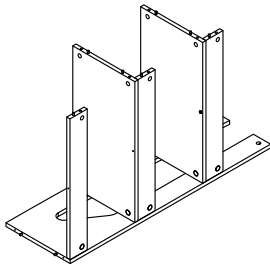

FERRAGEM

Hardware/Herraje



FERRAMENTA

Tool/Herramienta

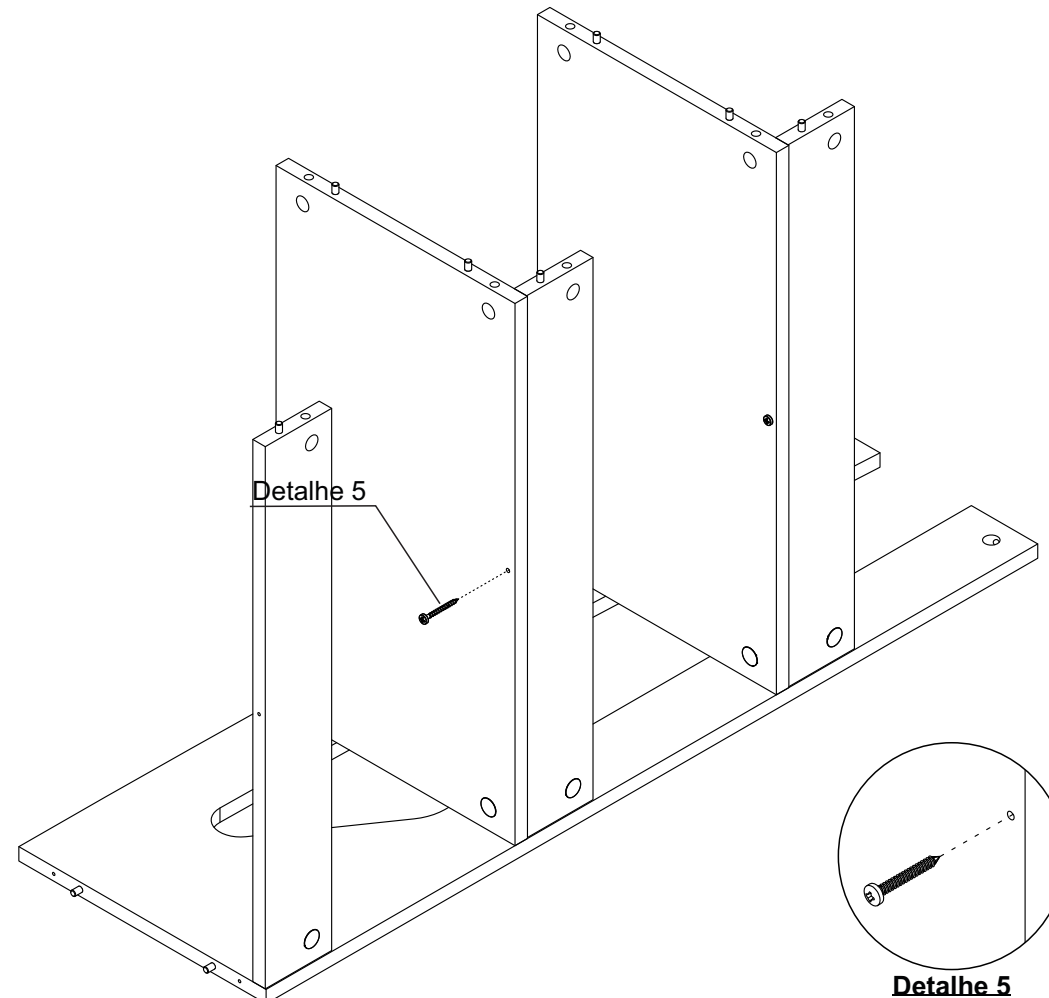
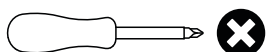

Detalhe 5

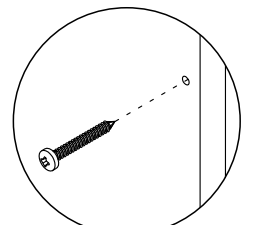

Detalhe 5
Detail/Detalle

Passo 11

Paso/Step

PEÇA
Piece/Pieza

3 - LATERAL DIR. INF. x1

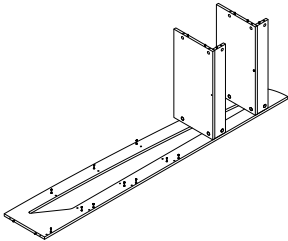

FERRAGEM
Hardware/Herraje

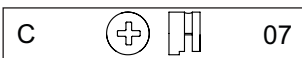

FERRAMENTA
Tool/Herramienta

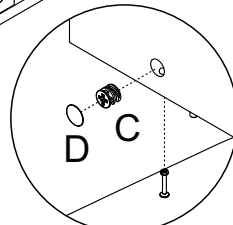
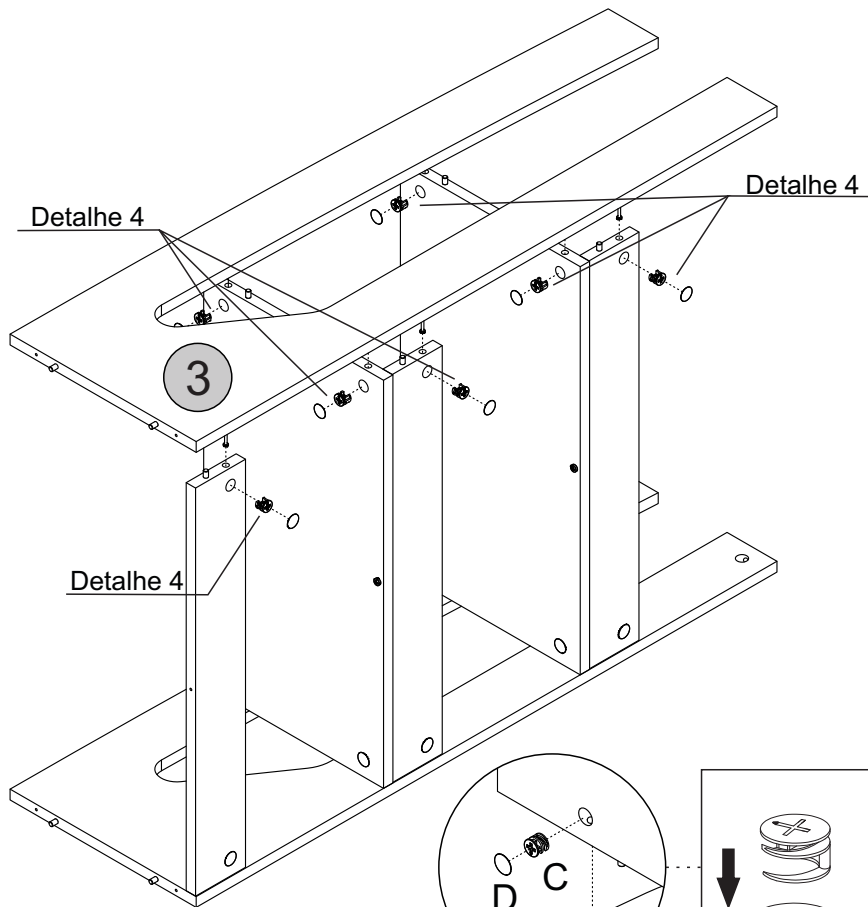
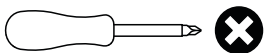

Detalhe 4
Detail/Detalle

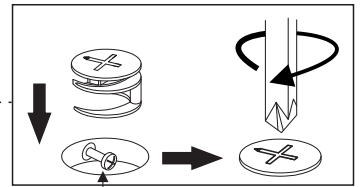

Cabeça do parafuso precisa estar no centro
La cabeza del tornillo debe estar en el centro
Screw head has to be in the center

Passo 12

Paso/Step

PEÇA
Piece/Pieza

1 - BASE x1

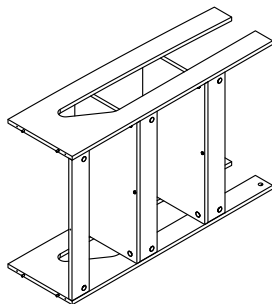

FERRAGEM
Hardware/Herraje

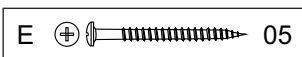

FERRAMENTA
Tool/Herramienta

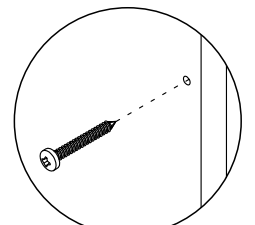
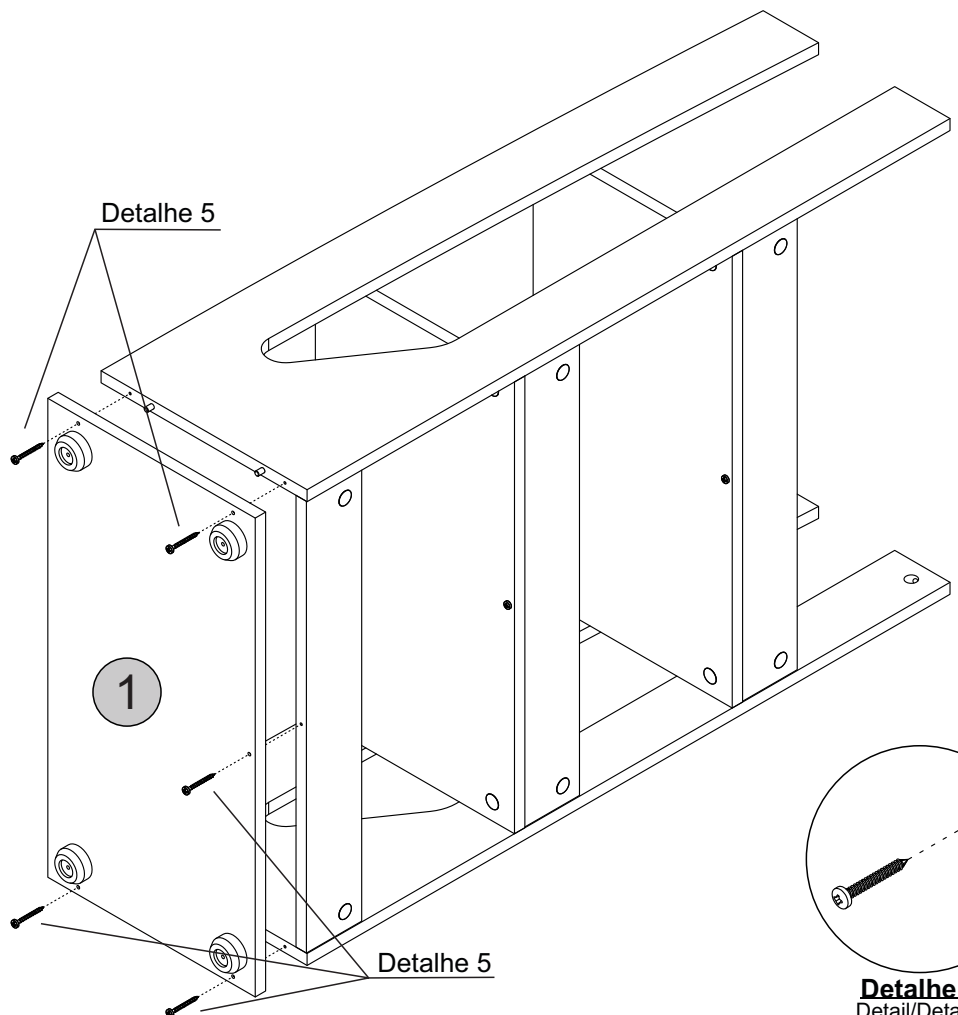
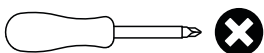

Detalhe 5
Detail/Detalle

Passo 13

Paso/Step

PEÇA

Piece/Pieza

5 - TRAVESSA x1

7 - PRATELEIRA SUP. x1

10 - LATERAL ESQ. SUP. x1

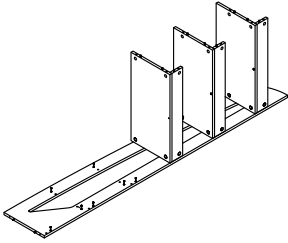

FERRAGEM

Hardware/Herraje

C   03

D  03

FERRAMENTA

Tool/Herramienta

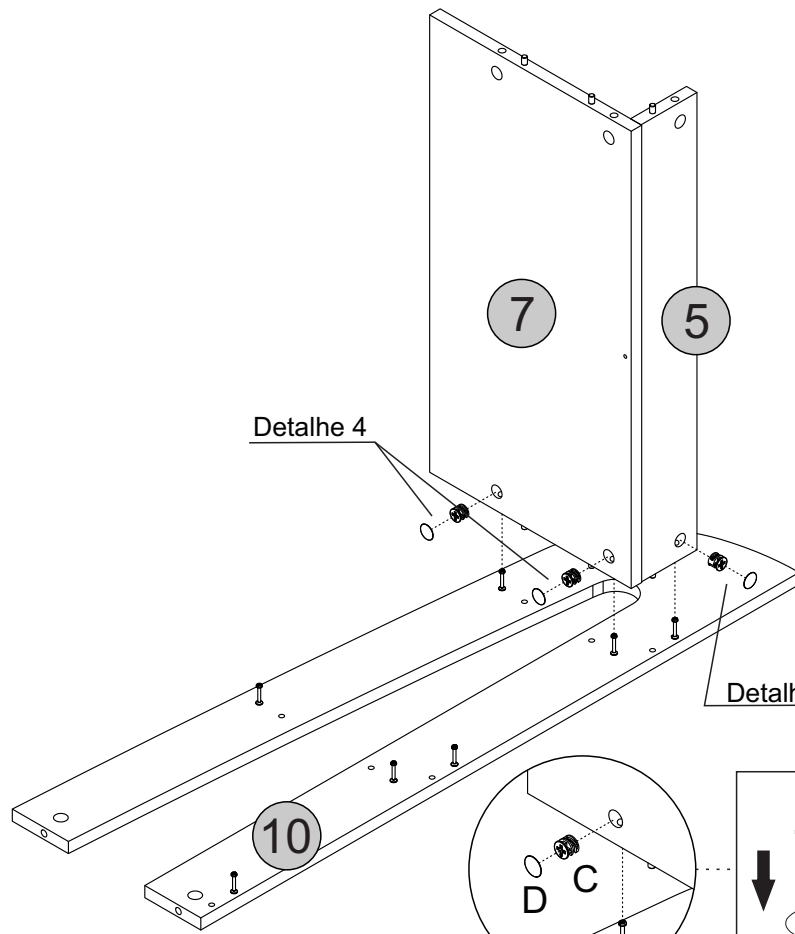
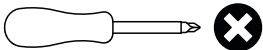

Detalhe 4
Detail/Detalle

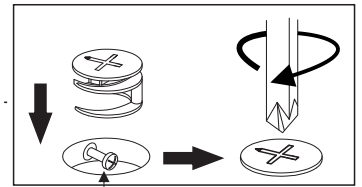

Cabeça do parafuso precisa estar no centro
La cabeza del tornillo debe estar en el centro
Screw head has to be in the center

Passo 14

Paso/Step

PEÇA

Piece/Pieza

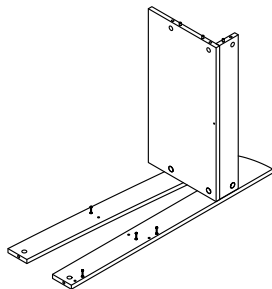

FERRAGEM

Hardware/Herraje

E  01

FERRAMENTA

Tool/Herramienta

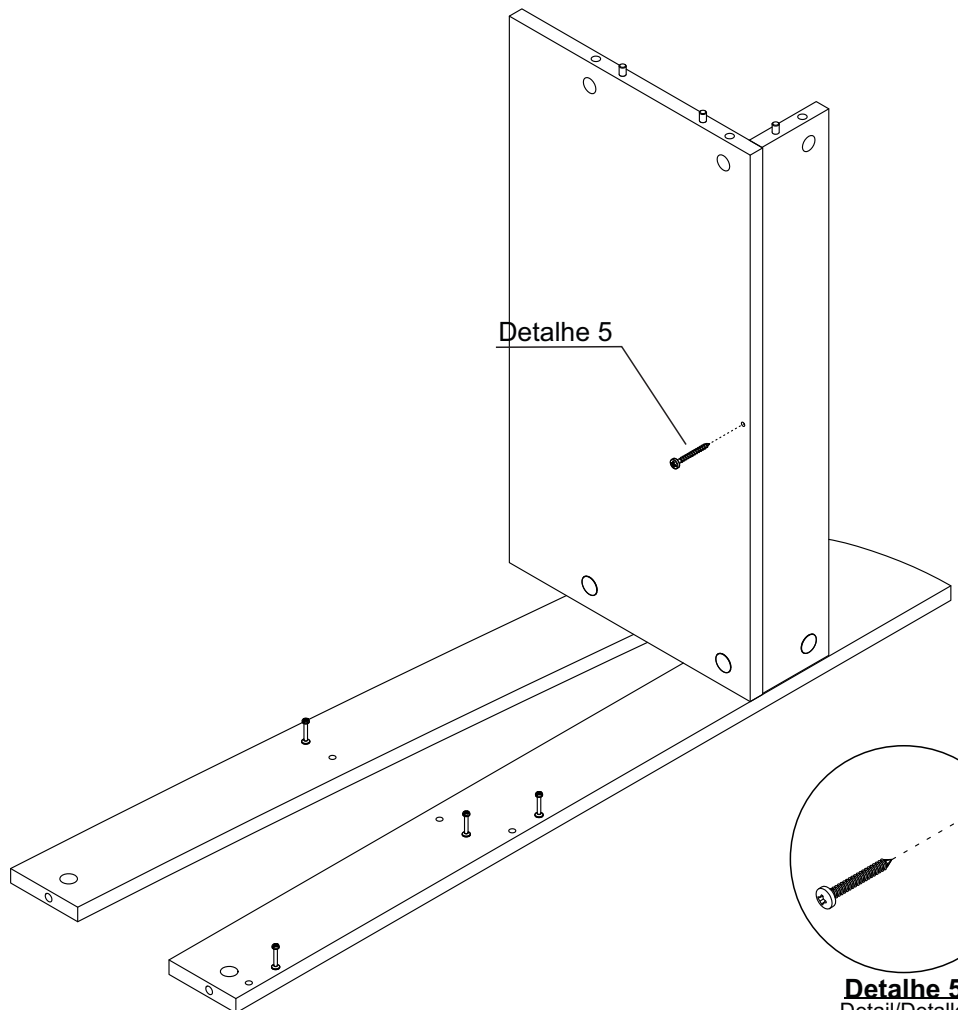
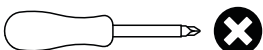

Detalhe 5
Detail/Detalle

Passo 15

Paso/Step

PEÇA

Piece/Pieza

5 - TRAVESSA x1

6 - PRATELEIRA INT. x1

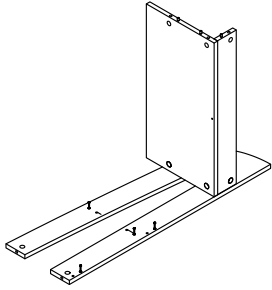

FERRAGEM

Hardware/Herraje

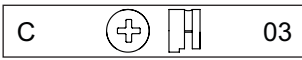

FERRAMENTA

Tool/Herramienta

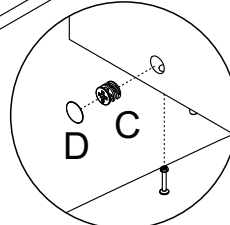
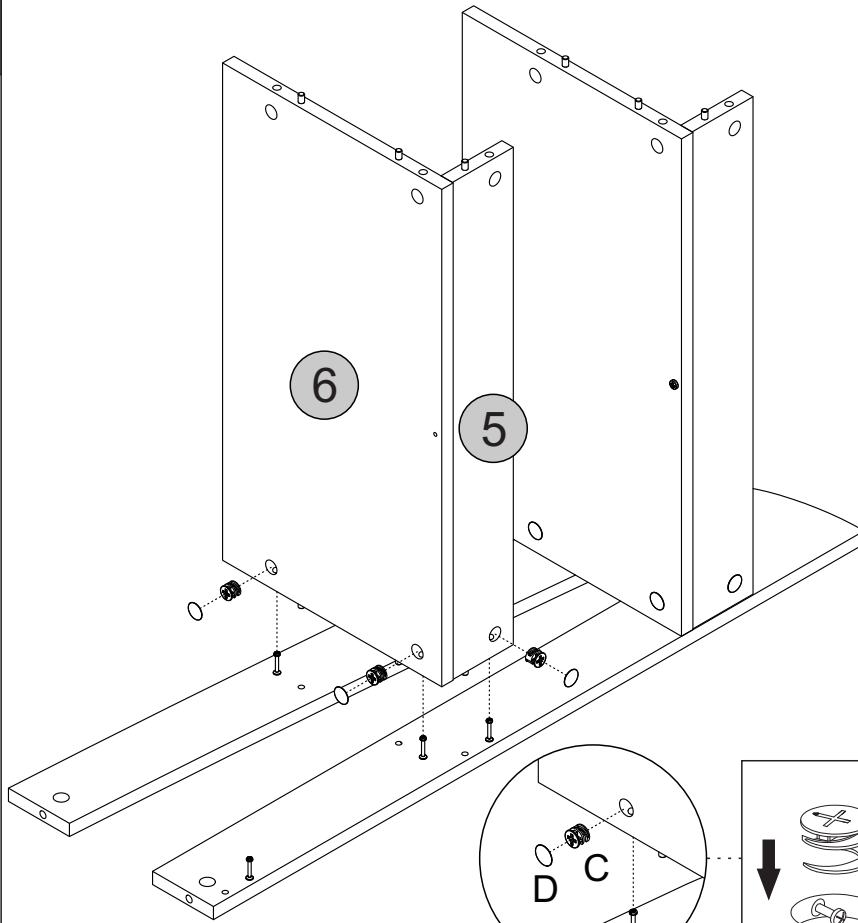
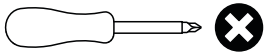

Detalhe 4
Detail/Detalle

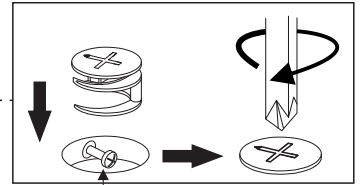

Cabeça do parafuso precisa estar no centro
La cabeza del tornillo debe estar en el centro
Screw head has to be in the center

Passo 16

Paso/Step

PEÇA

Piece/Pieza

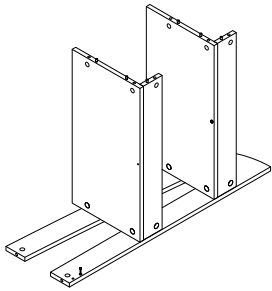

FERRAGEM

Hardware/Herraje



FERRAMENTA

Tool/Herramienta

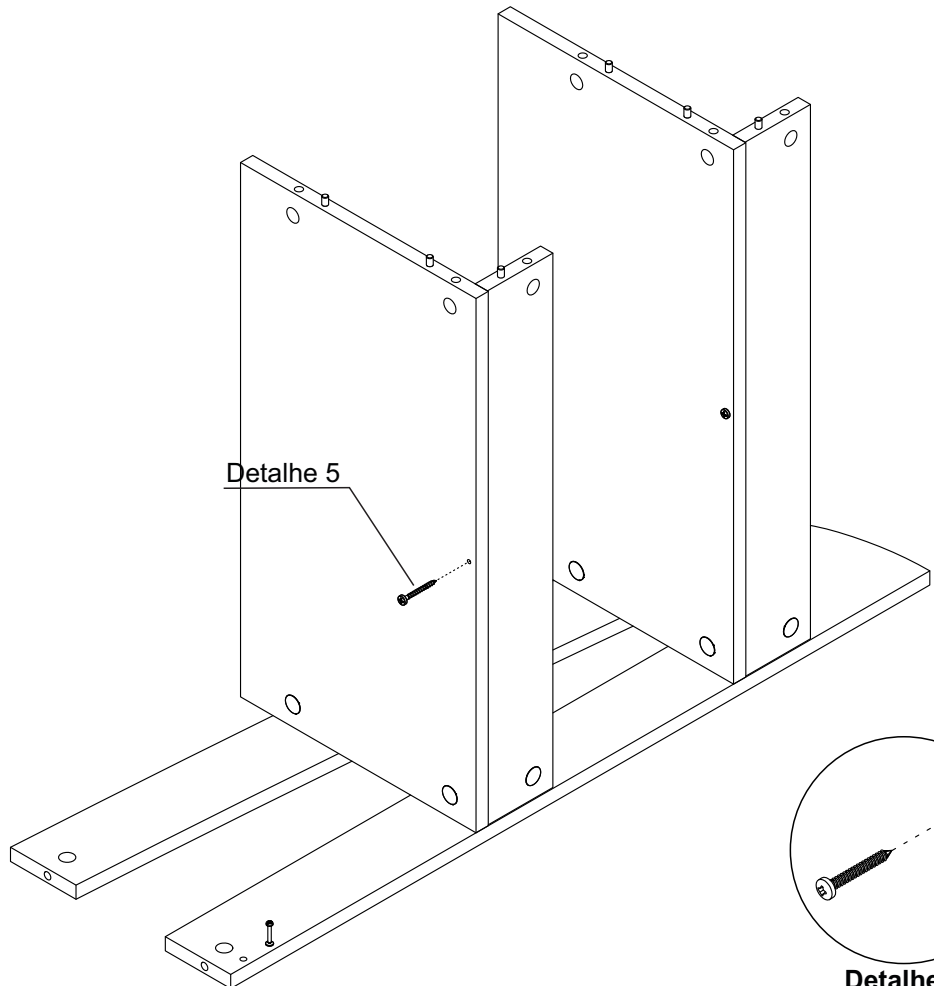
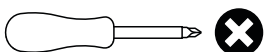

Detalhe 5

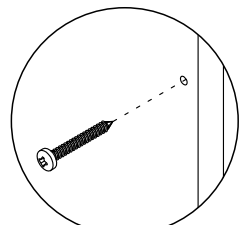

Detalhe 5
Detail/Detalle

Passo 17

Paso/Step

PEÇA

Piece/Pieza

5 - TRAVESSA x1

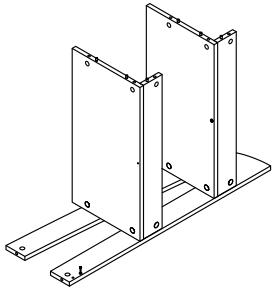

FERRAGEM

Hardware/Herraje

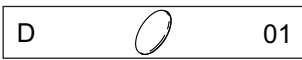
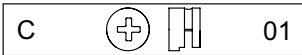

FERRAMENTA

Tool/Herramienta

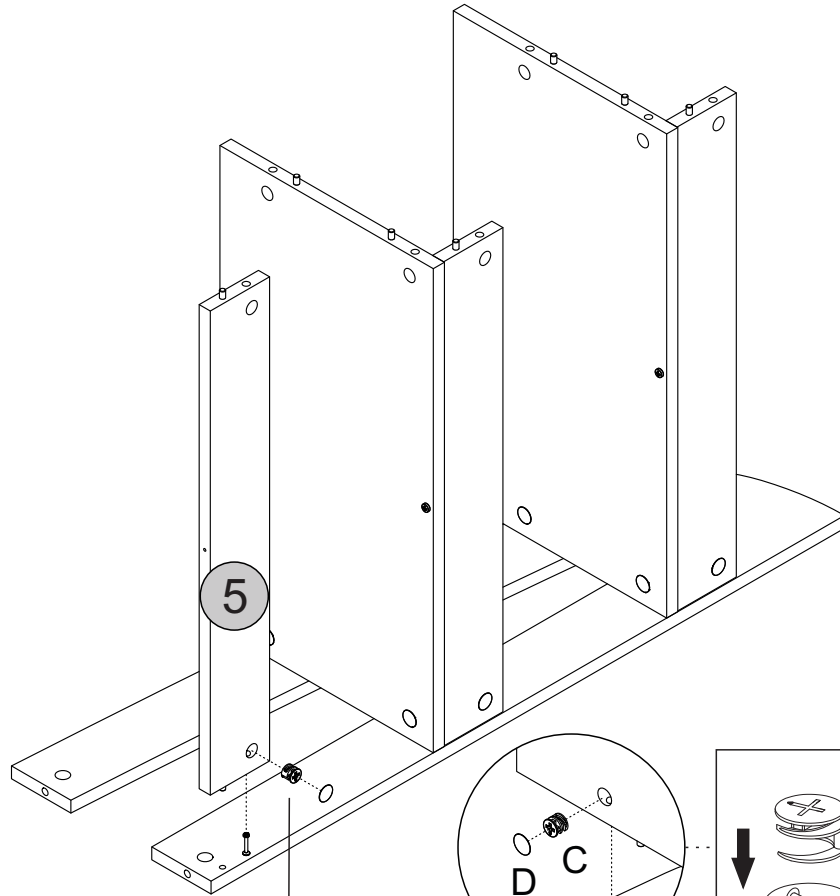
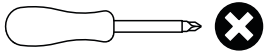

Detalhe 4

Detalhe 4
Detail/Detalle

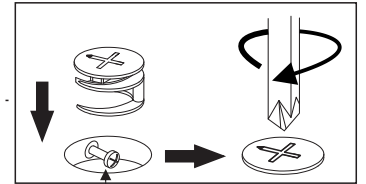

Cabeça do parafuso precisa estar no centro
La cabeza del tornillo debe estar en el centro
Screw head has to be in the center

Passo 18

Paso/Step

PEÇA

Piece/Pieza

9 - LATERAL DIR. SUP. x1

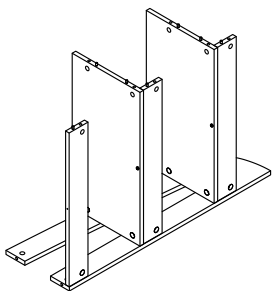

FERRAGEM

Hardware/Herraje

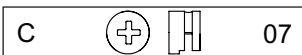

FERRAMENTA

Tool/Herramienta

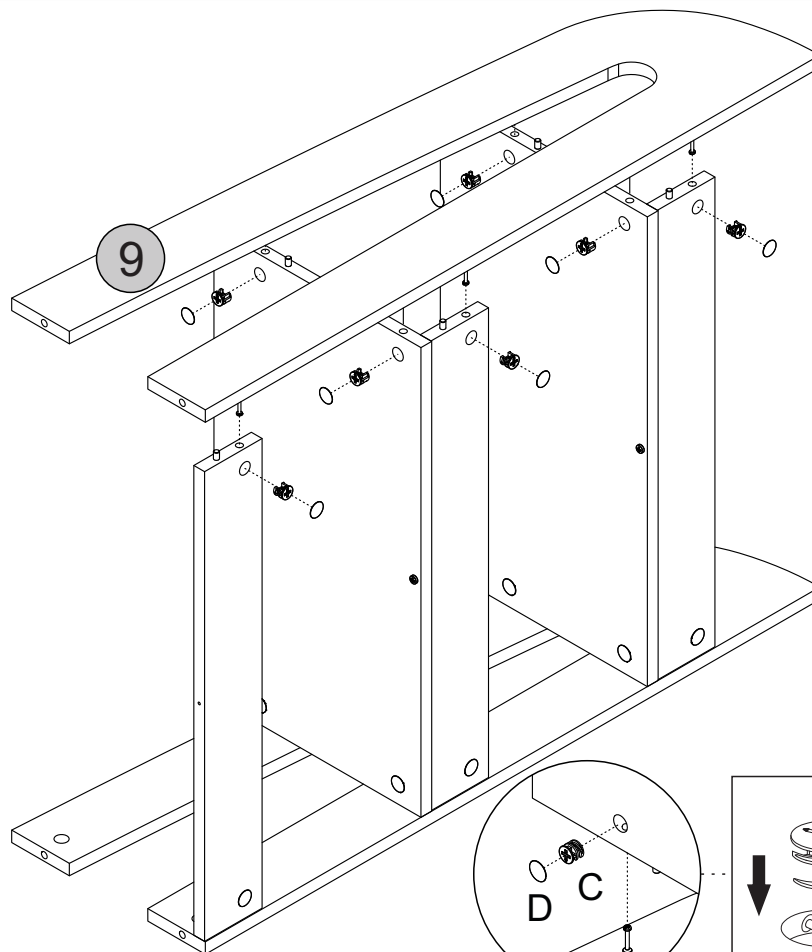
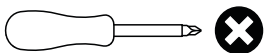

Detalhe 4
Detail/Detalle

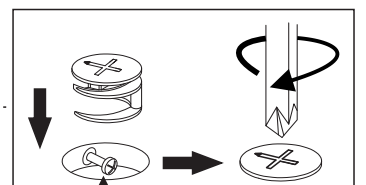

Cabeça do parafuso precisa estar no centro
La cabeza del tornillo debe estar en el centro
Screw head has to be in the center

Passo 19

Paso/Step

PEÇA
Piece/Pieza

8 - DIVISÃO x1

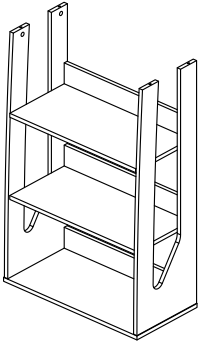

FERRAGEM
Hardware/Herraje

C		04
D		04
G		04

FERRAMENTA
Tool/Herramienta

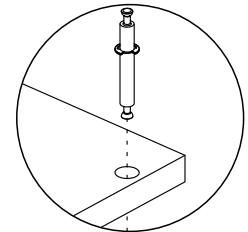
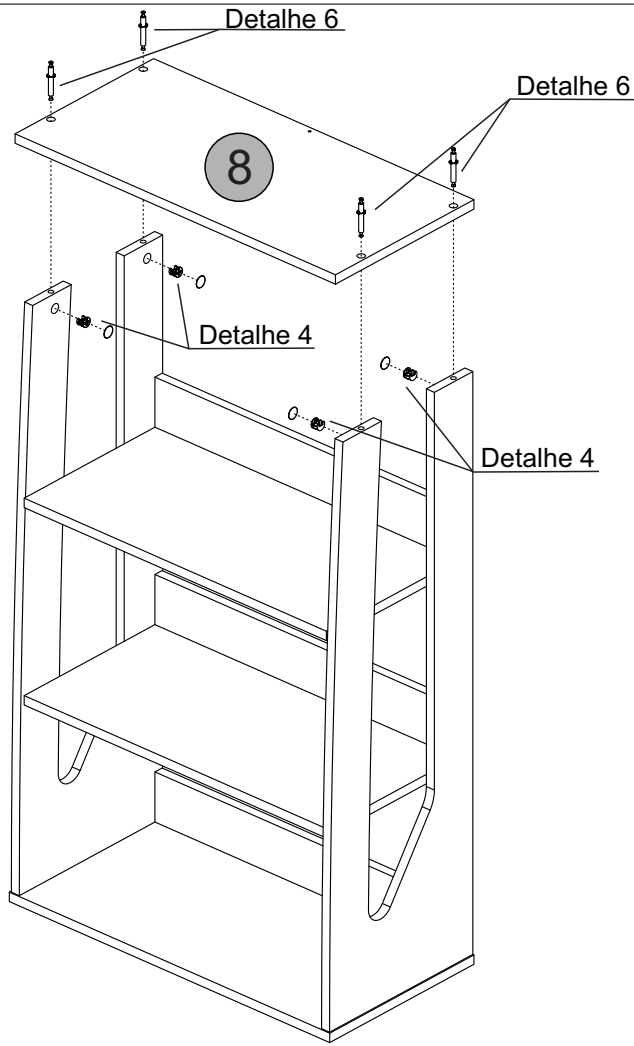
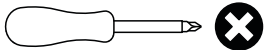

Detalhe 6
Detail/Detalle

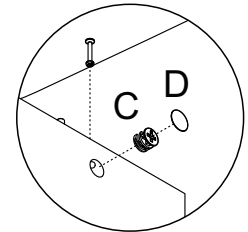

Detalhe 4
Detail/Detalle

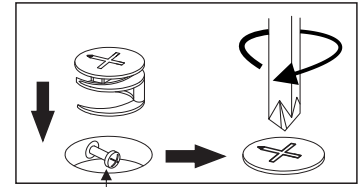

Cabeça do parafuso precisa estar no centro
La cabeza del tornillo debe estar en el centro
Screw head has to be in the center

Passo 20

Paso/Step

PEÇA
Piece/Pieza

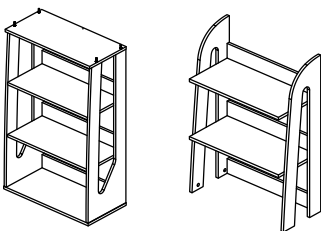

FERRAGEM
Hardware/Herraje

C		04
D		04

FERRAMENTA
Tool/Herramienta

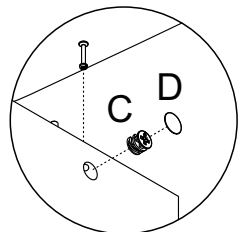
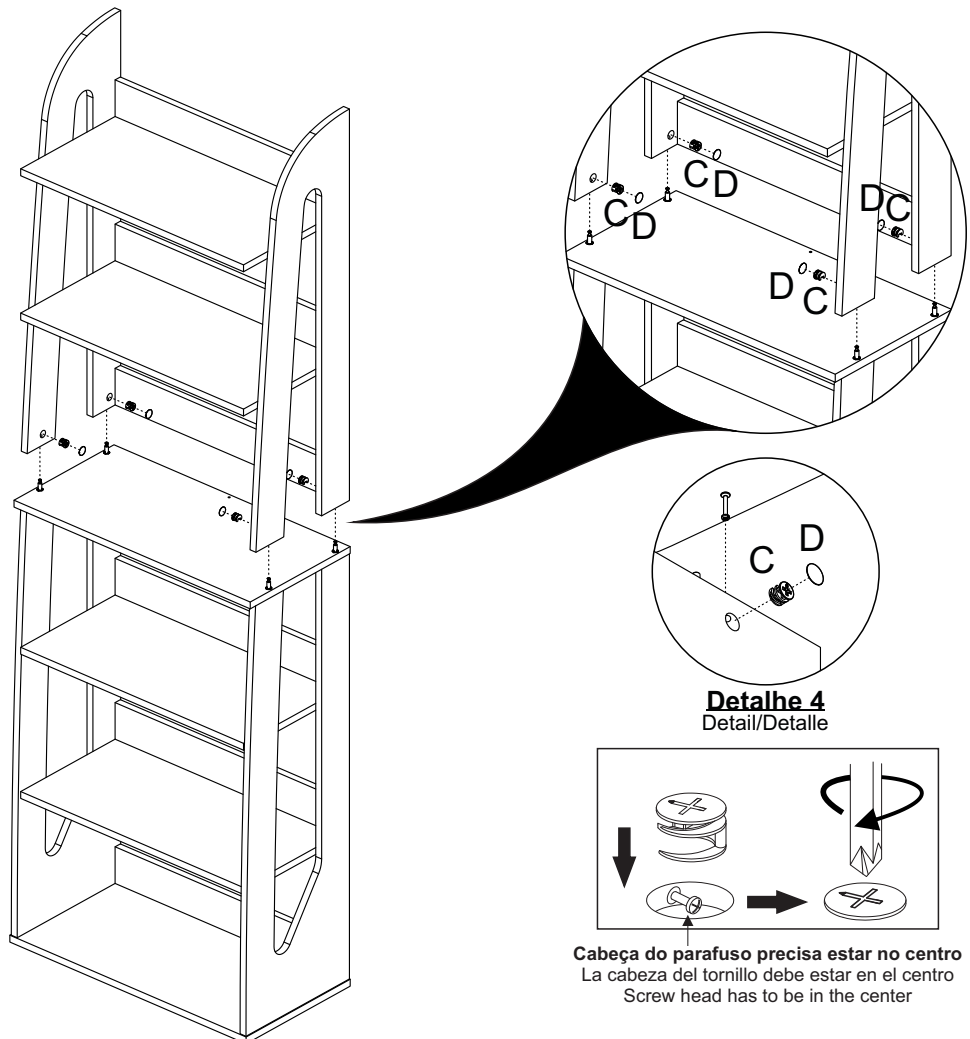
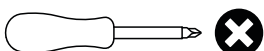

Detalhe 4
Detail/Detalle

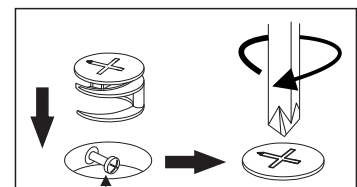

Cabeça do parafuso precisa estar no centro
La cabeza del tornillo debe estar en el centro
Screw head has to be in the center

Passo 21

Paso/Step

PEÇA
Piece/Pieza



FERRAGEM
Hardware/Herraje

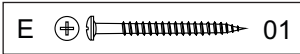

FERRAMENTA
Tool/Herramienta

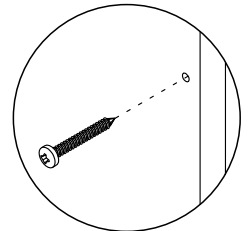
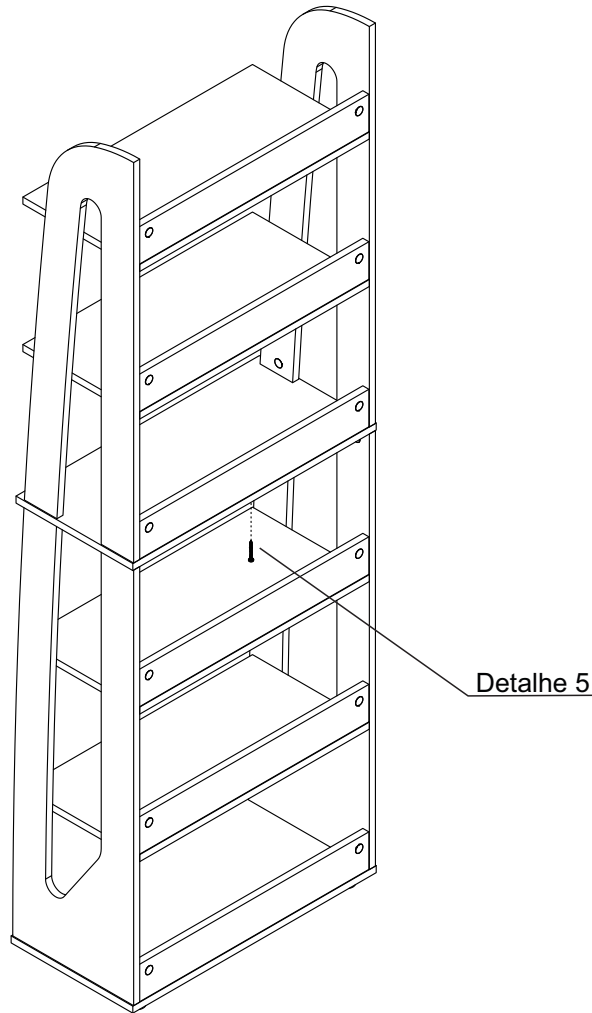
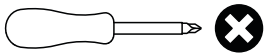

Detalhe 5
Detail/Detalle

Passo 22

Paso/Step

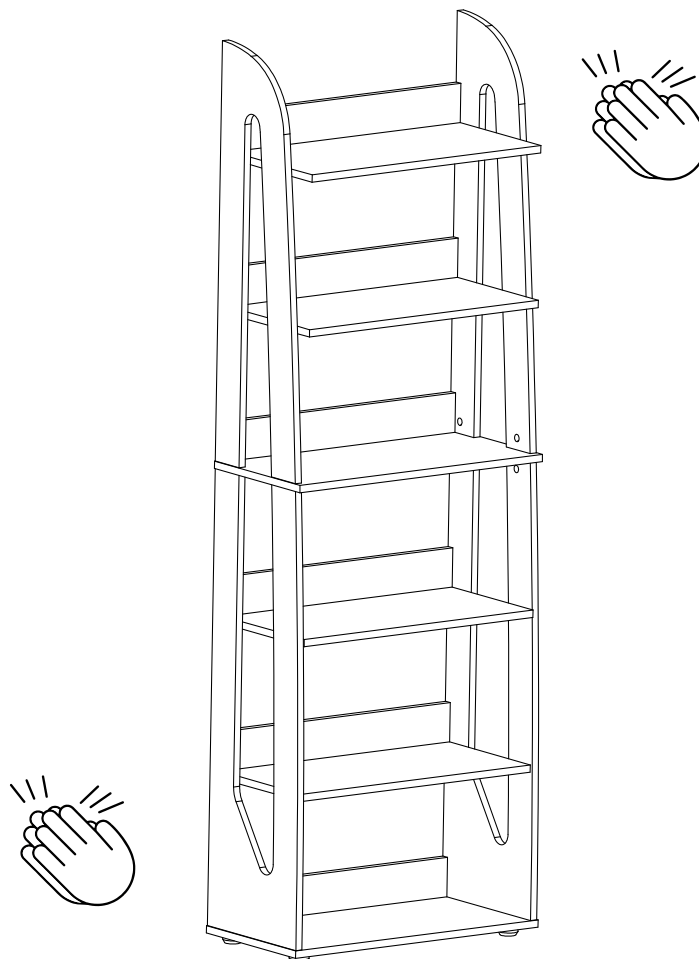

Parabéns, você montou seu móvel! Agora é só decorar sua casa e aproveitar!

Queremos ver como ficou o móvel Artely do seu jeito... Marque a gente com a #meuartely. Ficaremos felizes em compartilhar!

Ah, e se tiver qualquer dúvida, sugestão ou comentário, entra em contato com a gente pelo nosso site www.artely.com.br.

¡Congratulaciones, montaste tu mueble! ¡Ahora solo decora tu casa y disfruta!

Queremos ver este producto en tu hogar, a tu manera... Utilice #meuartely, ¡ficaremos encantados de compartir tu foto!

Si tienes alguna duda, sugerencia o comentario, contáctenos a través de nuestro sitio web www.artely.com.br.

Congratulations, you've assembled your new furniture! Decorate your home and enjoy!

We want to see how this product is in your home... Use #meuartely, we will be happy to share your picture!

If you have any doubt, suggestion or comment, get in touch with us through our website www.artely.com.br.