

Rack e Painel Roma IV

Rack e Painel Roma IV / Roma IV Panel and Rack

Versão 1.0 / Versión 1.0 / Version 1.0

www.artely.com.br

frente

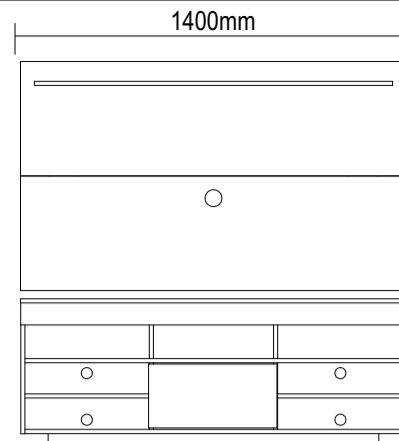

lateral

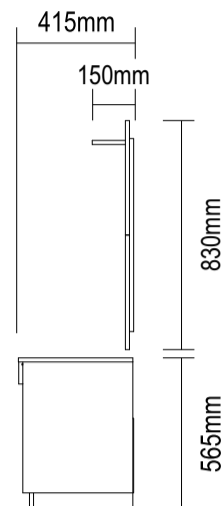

Conservação e Limpeza

Conservación y Limpieza Conservation and Cleaning

Não expor o produto ao sol, altas temperaturas e umidade. Não arrastar objetos sobre a superfície do móvel (ex.: TV, DVD, aparelho de som, objetos decorativos...) e manter em local seco e arejado.

Para a limpeza, utilizar um pano seco e macio. Não é necessário o uso de materiais abrasivos ou álcool.

No exponga el producto a la luz solar, las altas temperaturas y la humedad. No arrastre los objetos a través de la superficie de la unidad (por ejemplo, TV, DVD, equipo de música, objetos de decoración ...) Mantener en un lugar fresco y seco.









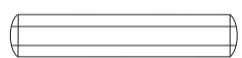

Para la limpieza, utilizar un paño seco y suave. El uso de materiales abrasivos o del alcohol no es necesario.

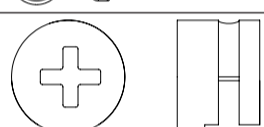

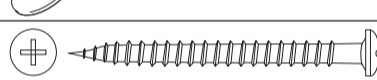

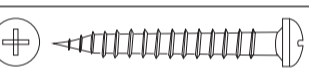

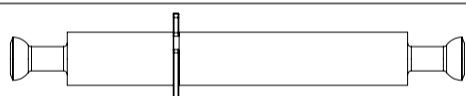
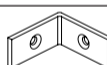

Do not expose the product to sunlight, high temperatures and humidity. Do not drag objects across the surface of the unit (TV, DVD, stereo, decorative objects ...) keep it in a cool dry place.

For cleaning, use a dry and soft cloth. Do not use abrasive materials or alcohol.

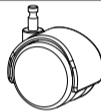
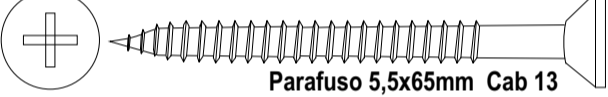
Lista de Materiais

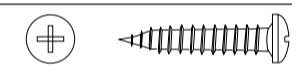
Lista de Materiales/ Hardware List

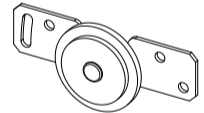
A		Cavilha	42
B		Minifix	12
C		Tambor	16
D		Tapa Furo Adesivo	04
E		Parafuso Ø3,5x40mm CP	07
F		Perfil Canal / Channel 1366mm	01
H		Parafuso Ø4,0x30mm CP	10
J		Prego 8x8	22
K		Haste dupla Minifix Ø7x60mm	02
M		Cantoneira 1"x1"	10
N		Suporte Angular	05

P		Parafuso Ø4,0x14mm CP	34
Q		Buchas	06
R		Rodízio RF40	06
S		Parafuso 5,5x65mm Cab 13	04
T		Buchas Ø8mm	04
U		Passa Fio Ø60mm	01
V		Parafuso Ø4,0x20mm CP	20
W		Junção	01
X	  	Guia Roldana Parafuso Ø3,5x12mm CF	01

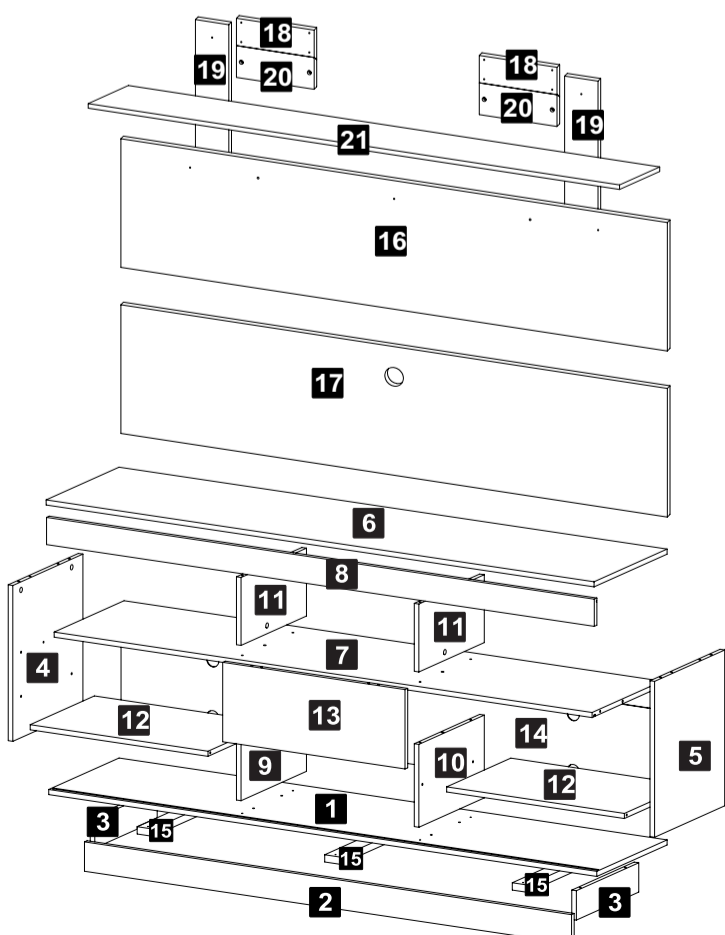

O número na borda da peça corresponde ao manual.
- Para retirar do número usar Lustra-Móveis ou Alcool em Gel.
- El número en el borde de la pieza coincide con el manual.
- Use alcohol en gel o lustrador para muebles para eliminar los números.
- The number on the edge of the piece matches the manual.
- Use Alcohol Gel or Furniture Polish to remove the numbers.

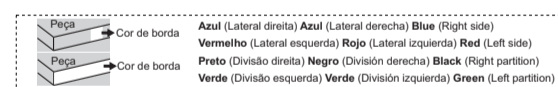

Descrição	Descripción	Description	Qty
1-Base (1368x398x15mm)	1-Base	1-Base	1
2-Rodapé frontal (1200x65x15mm)	2-Rodapié	2- baseboard	1
3-Rodapé lateral (360x65x15mm)	3-Rodapié lateral	3-Side baseboard	2
4-Lateral esquerda (475x399x15mm)	4-Lateral izquierda	4-Left side	1
5-Lateral direita (475x399x15mm)	5-Lateral derecha	5-Right side	1
6-Tampo (1400x415x15mm)	6-Tapa	6-Top	1
7-Prateleira maior (1368x398x15mm)	7-Anaqueil mayor	7-Bigger shelf	1
8-Encabeçamento tampo (1399x80x15mm)	8-Encabezado tapa	8-Top header	1
9-Divisão inferior esq. (242x370x15mm)	9-Division inferior izquierda	9-Left back partition	1
10-Divisão inferior dir. (242x370x15mm)	10-Division inferior derecha	10-Right back partition	1
11-Divisão superior (202x370x15mm)	11-Division superior	11-Upper Partition	2
12-Prateleira menor (451x365x15mm)	12-Anaqueil menor	12-Small shelf	2
13-Porta (466x236x15mm)	13-Puerta	13-Door	1
14-Traseira (1387x269x3mm)	14-Trasera	14-Back	1
15-Travessa rodízio (320x60x25mm)	15-Travesaño ruedecilla	15-Caster crosspiece	3
16-Painel superior (1400x415x15mm)	16-Panel superior	16-Upper panel	1
17-Painel inferior (1400x415x15mm)	17-Panel inferior	17-Lower panel	1
18-Travessa menor (256x105x15mm)	18-Travesaño menor	18-Small crosspiece	2
19-Travessa maior (700x105x15mm)	19-Travesaño mayor	19-Bigger crosspiece	2
20-Travessa parede (256x105x15mm)	20-Travesaño pared	20-Wall crosspiece	2
21-Prateleira (1300x120x15mm)	21-Anaqueil	21-Shelf	1

Assista ao vídeo com dicas de montagem em nosso site: www.artely.com.br

1 Passo Paso Step

Rack

A Cavilha 08 **B** Minifix 07x30mm 06 **H** Parafuso 04,0x30mm CP 06

F Perfil 1366mm 01

2 Passo Paso Step

X1 Guia 02 **X2** Rodana 02 **X3** Parafuso 03,5x12mm CF 06

-Colocar o parafuso centralizado no furo oblongo para poder ajustar.
-Coloque el tornillo en el centro del orificio oblongo para que pueda ajustarlo.
-Put the screw centralized in the oblong hole.

-Utiliza o gabarito da última folha para fixar o kit porta de correr.
-Use la plantilla de la última hoja para armar el Kit de la Puerta Deslizante.
-Use the Door Mounting template in the last page to attach the sliding door kit.

3 Passo Paso Step

(2x)

A Cavilha 12 **M** Cantoneira 1"x1" 06 **P** Parafuso 04,0x14mm CP 06

-Aproximadamente 1mm da borda
-Aproximadamente 1 mm desde el borde
-Around 1mm of the edge.

4 Passo Paso Step

A Cavilha 20 **B** Minifix 07x30mm 06 **M** Cantoneira 1"x1" 02 **P** Parafuso 04,0x14mm CP 02

5 Passo Paso Step

C Tambor 02 **D** Tapa Furo Adesivo 02 **K** Haste dupla 07x60mm 02

6 Passo Paso Step

E Parafuso 03,5x40mm CP 04

⚠️

-Encaixar a porta conforme o desenho.
-Montar la puerta según el dibujo.
-Fit the door according to the drawing.

7
Passo
Paso
Step

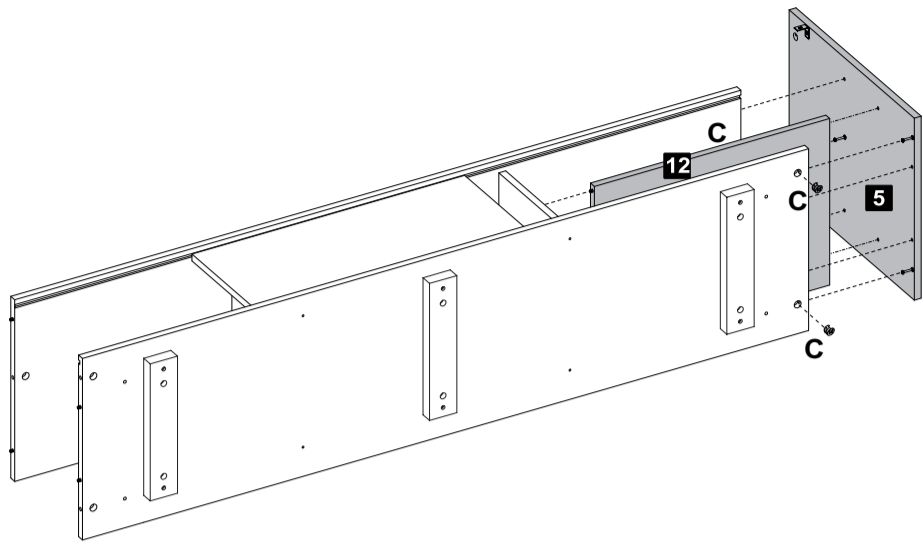
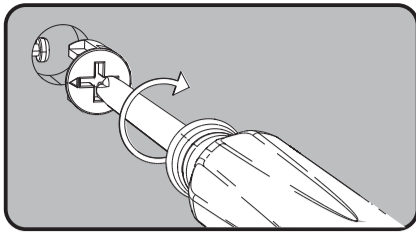

C Tambor 03

8
Passo
Paso
Step

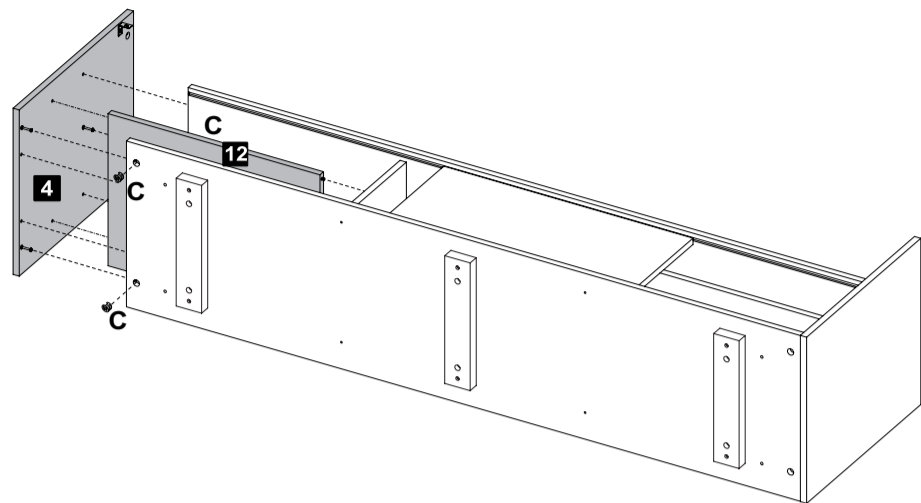
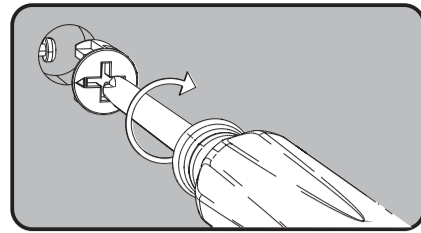

C Tambor 03

9
Passo
Paso
Step

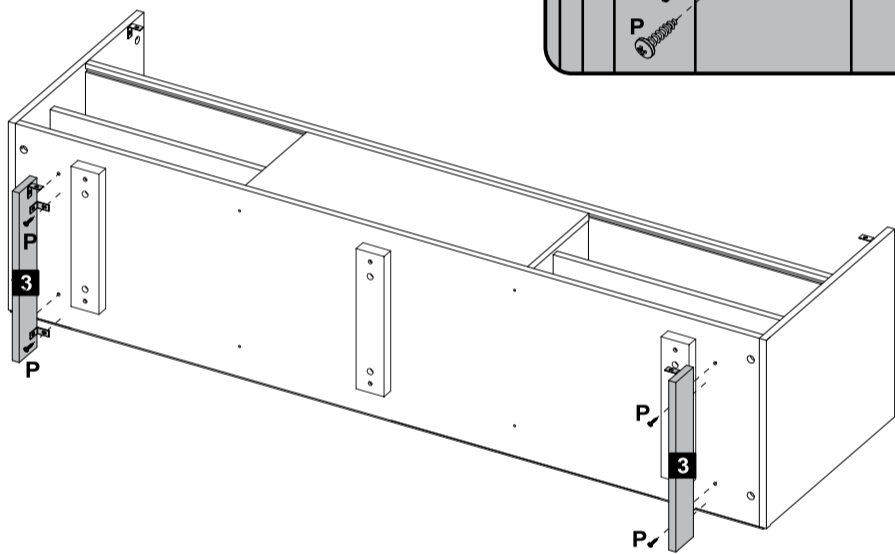
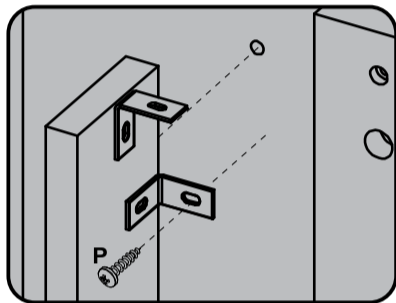

P Parafuso Ø4,0x14mm CP 04

10
Passo
Paso
Step

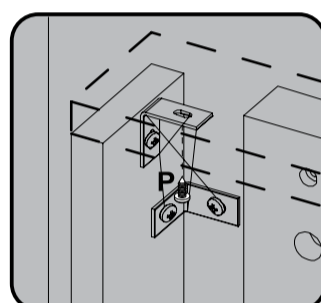
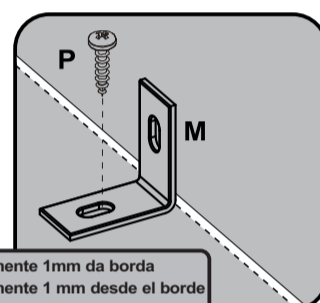

-Aproximadamente 1mm da borda
-Aproximadamente 1 mm desde el borde
-Around 1mm of the edge.

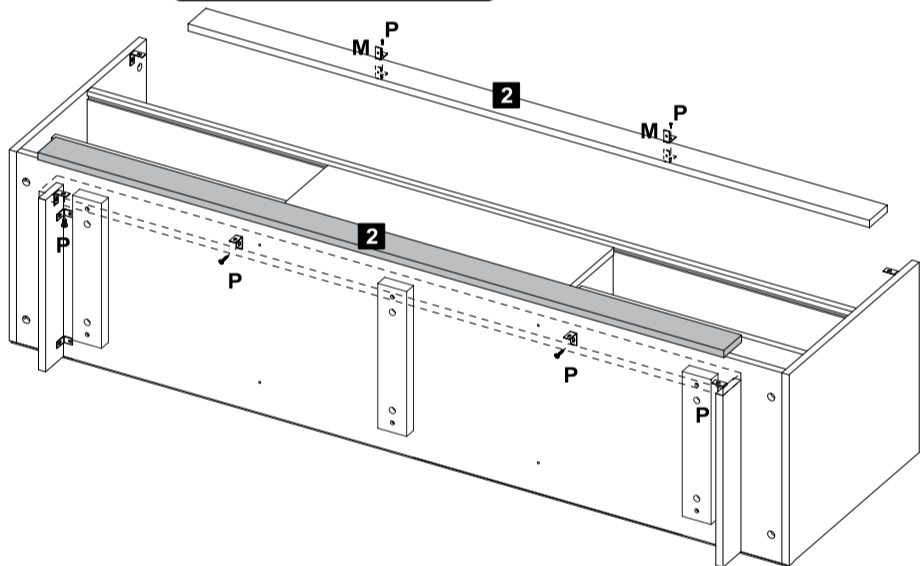

M Cantoneira 1"x1" 02 P Parafuso Ø4,0x14mm CP 06

11
Passo
Paso
Step

- Após colocar a bucha na peça, encaixar o rodizio usando uma determinada força até dar um "CLICK".
- Después de colocar el casquillo en el pieza, ajuste la rueda firmemente hasta que haga clic.
- After placing the bushing on the piece, fit the caster tightly until it clicks.

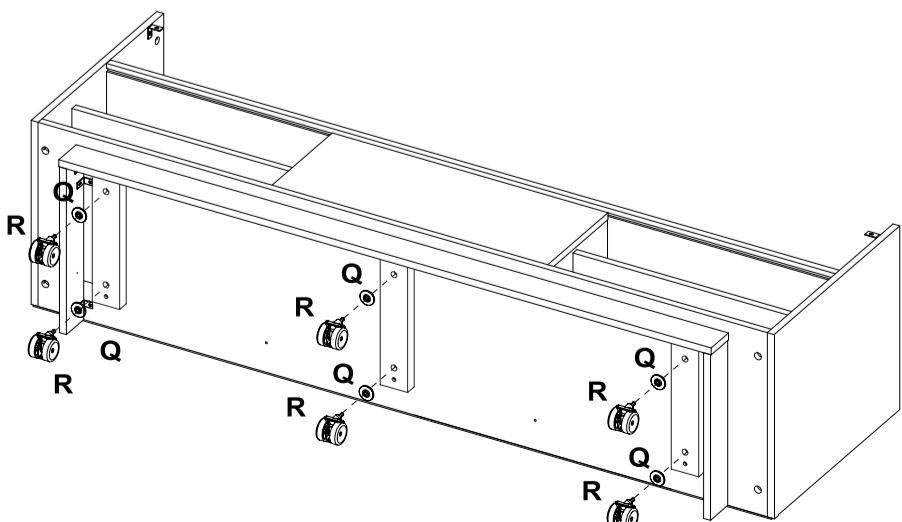
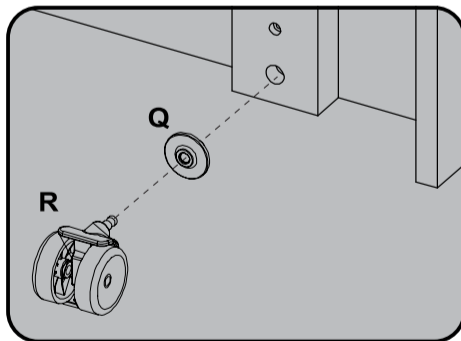

Q Bucha 06 R Rodizio RF40 06

12
Passo
Paso
Step

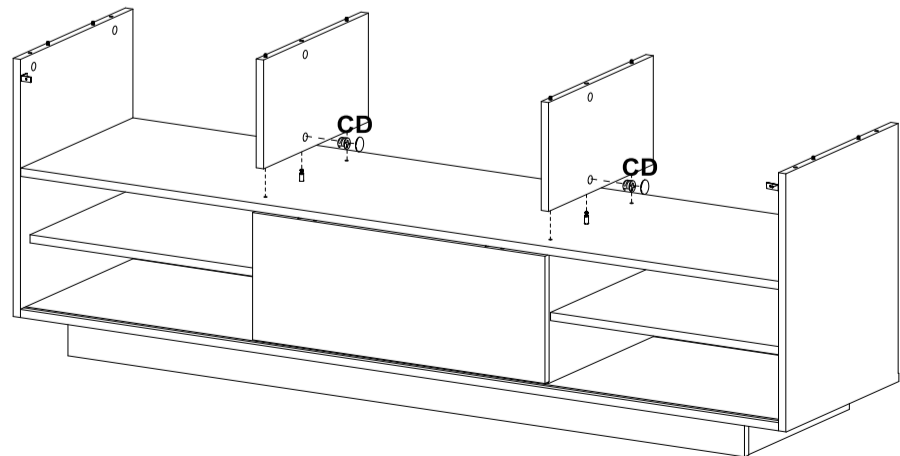

C Tambor 02 D Tapa Furo Adesivo 02

13 Passo
Paso
Step

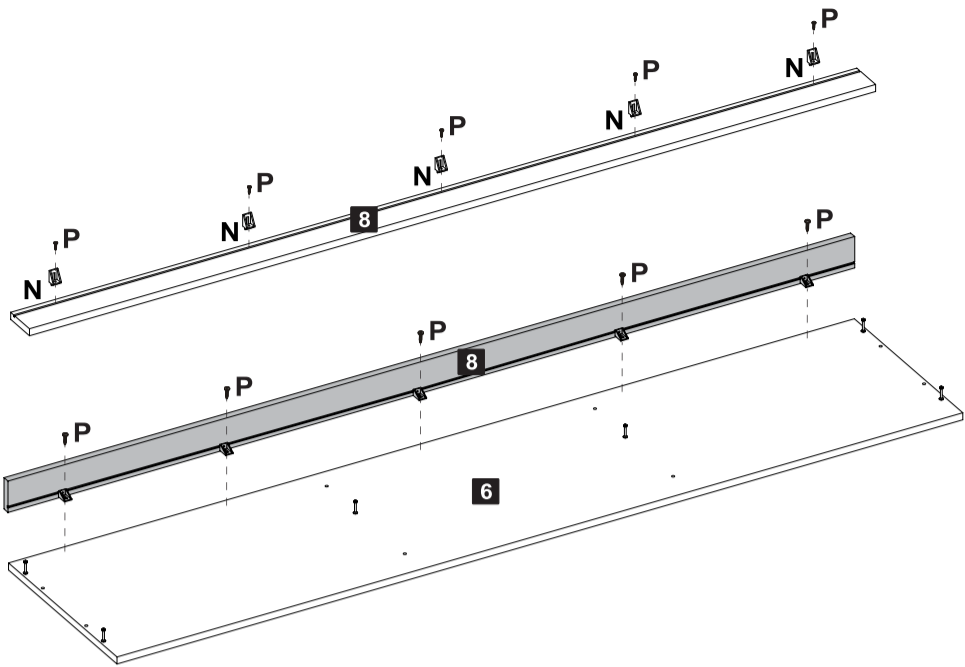
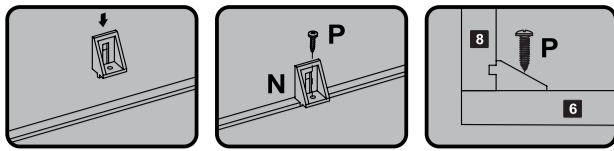

N Suporte Angular 05 P Parafuso Ø4,0x14mm CP 10

14 Passo
Paso
Step

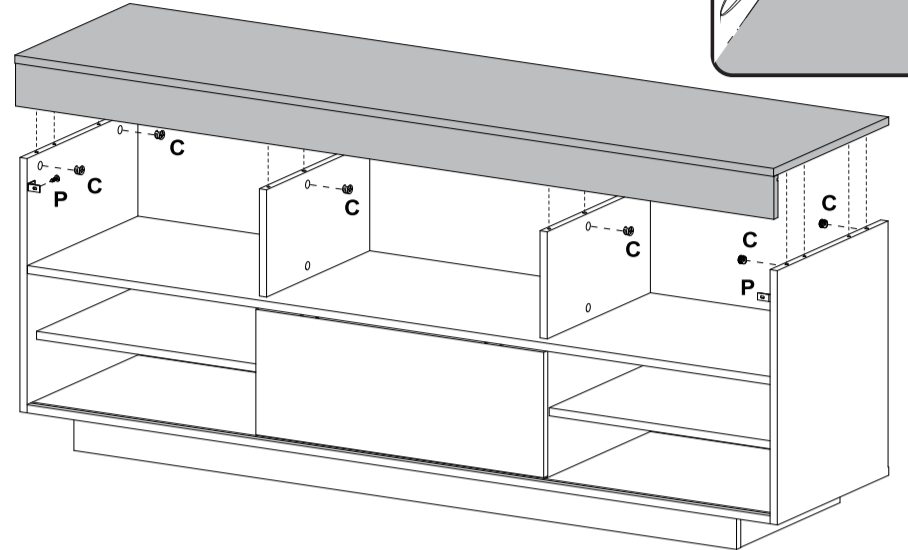
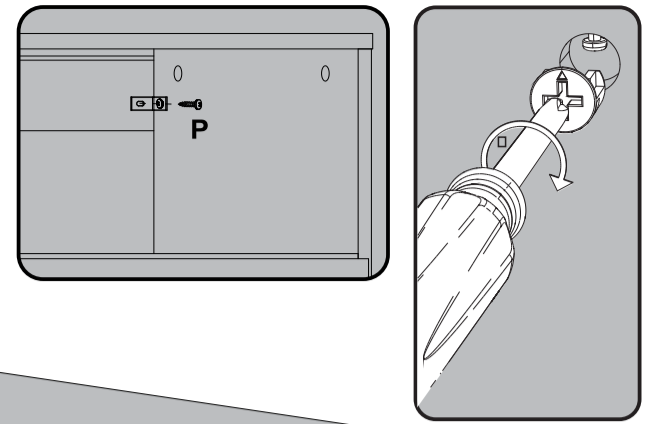

C Tambor 06 P Parafuso Ø4,0x14mm CP 02

15 Passo
Paso
Step

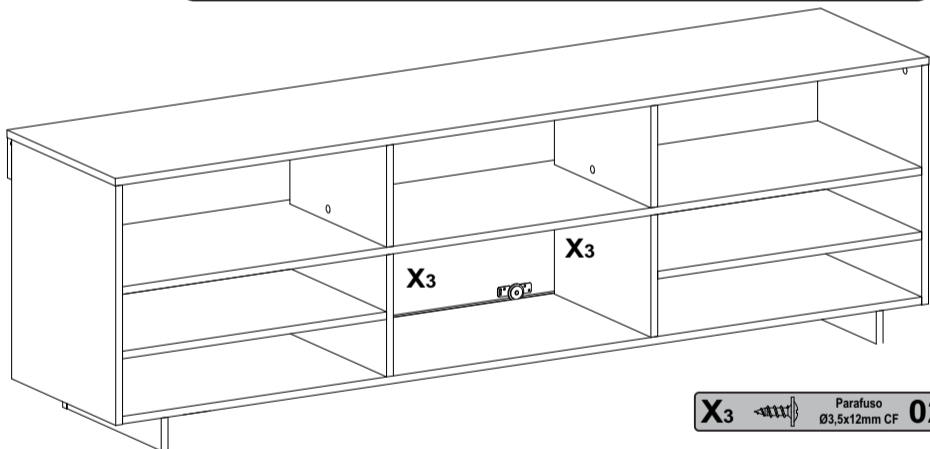
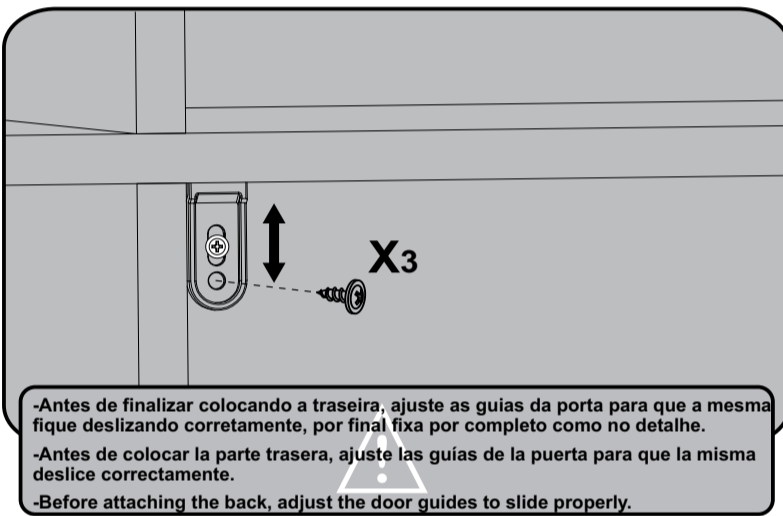

X3 Parafuso Ø3,5x12mm CF 02

16 Passo
Paso
Step

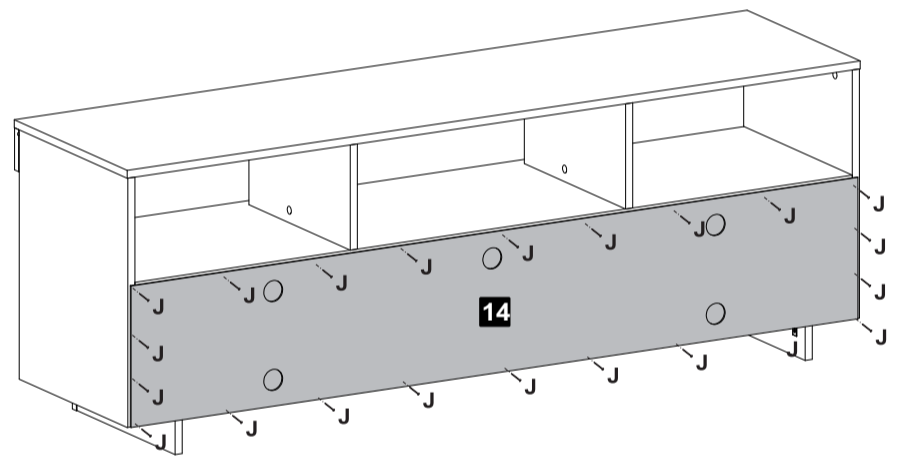

J Tambor 22

17 Passo
Paso
Step

Painel

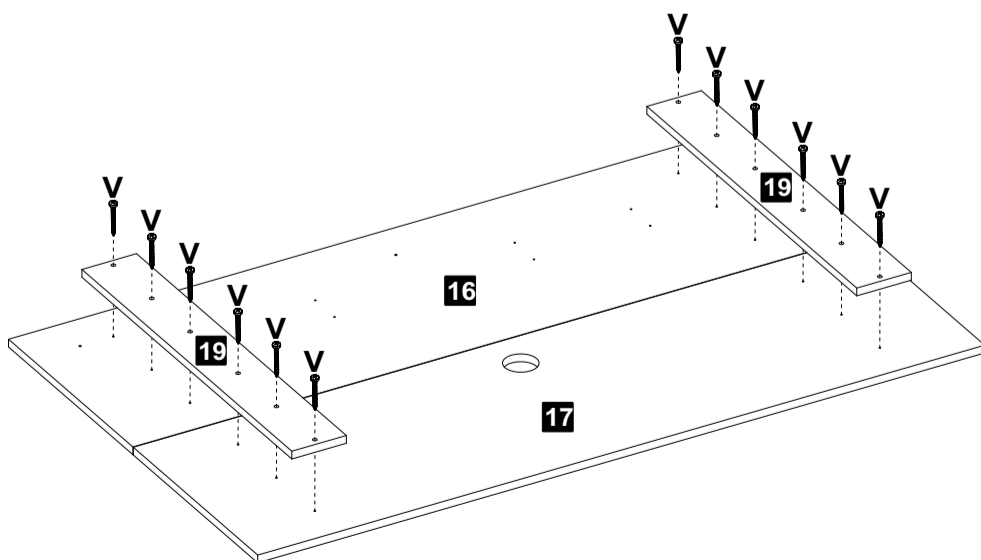

V Parafuso Ø4,0x20mm CP 12

18 Passo
Paso
Step

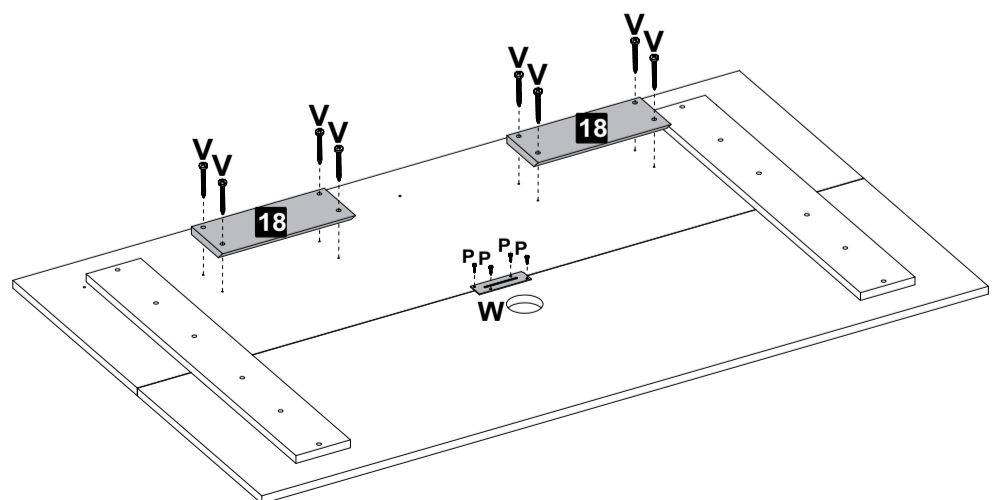
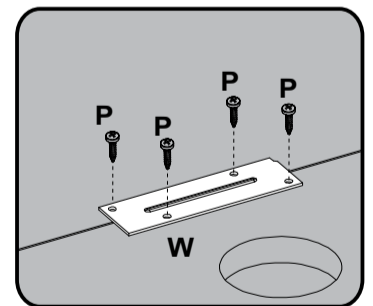

P Parafuso Ø4,0x14mm CP 04 V Parafuso Ø4,0x20mm CP 08 W Junção 01

19 Passo
Paso
Step

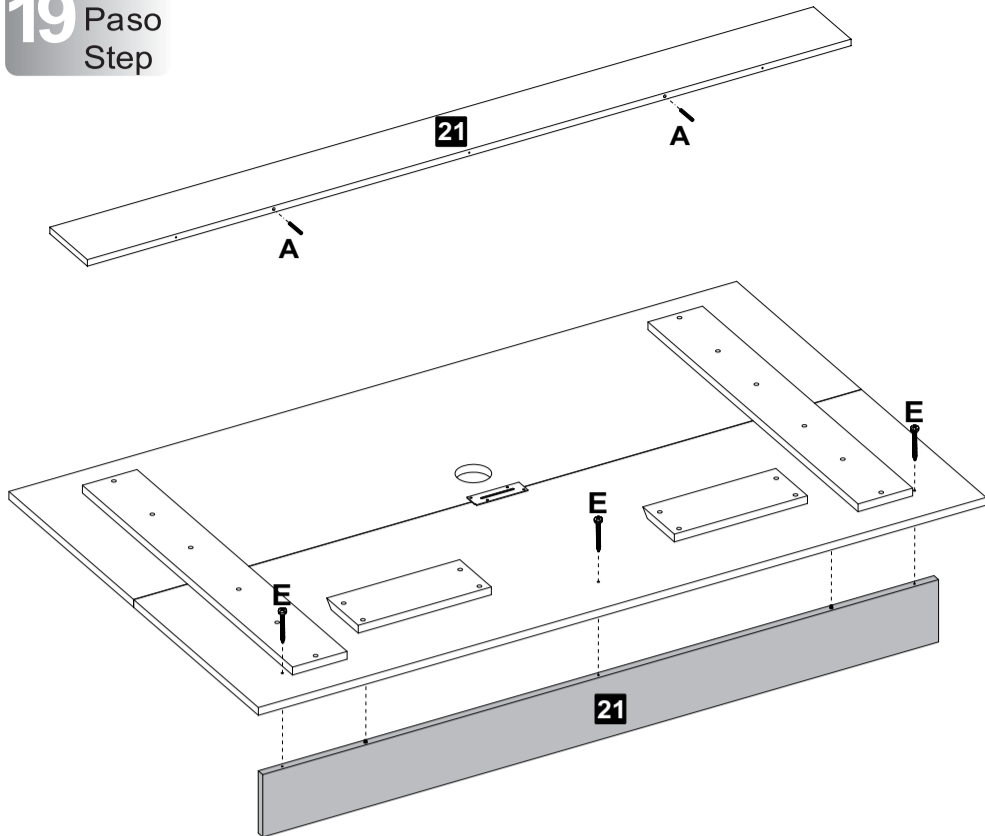

A Cavilha 02 E Parafuso Ø3,5x40mm CP 03

20 Passo
Paso
Step

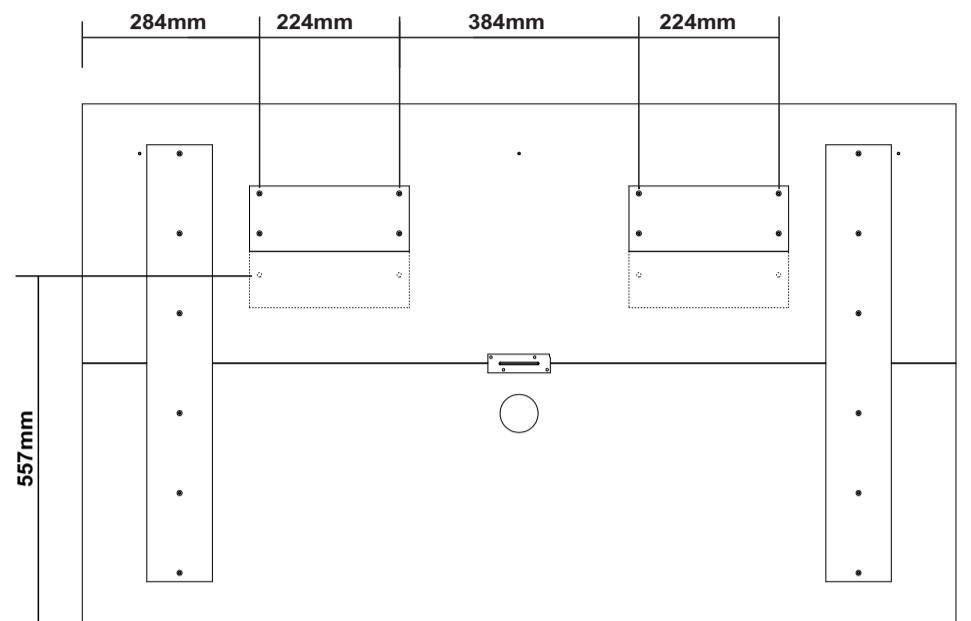

21 Passo
Paso
Step

Esquema de furação da parede / Esquema de perforación de la pared / Wall drilling Scheme

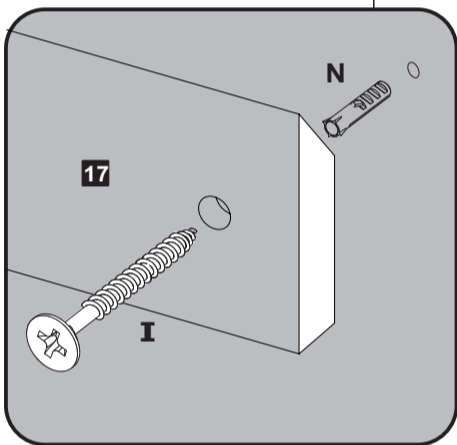

PAREDE
pared
wall

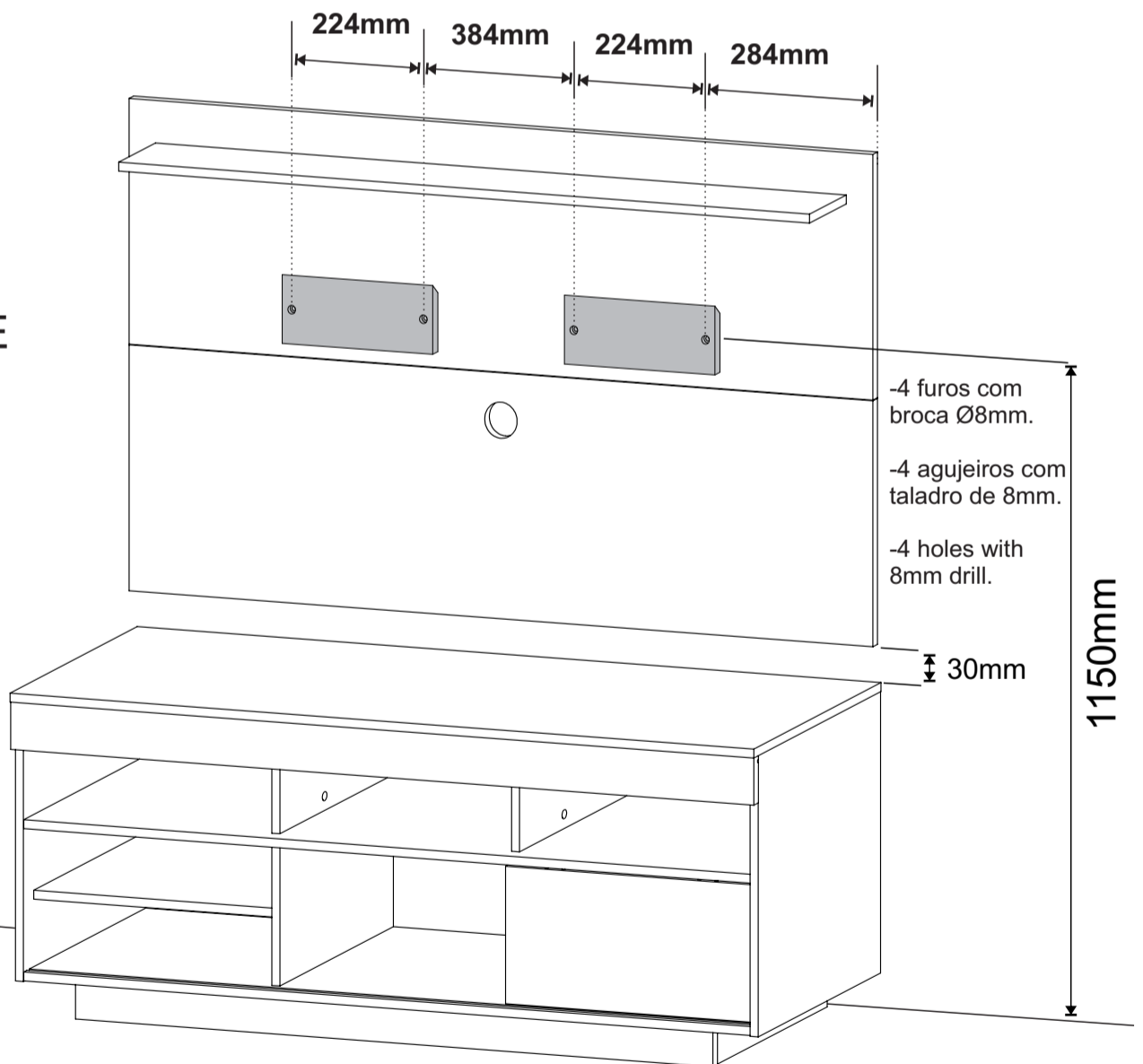

-4 furos com broca Ø8mm.
-4 agujeros con taladro de 8mm.
-4 holes with 8mm drill.

1150mm

30mm

PISO
piso
floor

Obs: -Nivelar as travessas na parede.
-Nivelar los travesaños en la pared.
-Level the crosspieces on the wall.

I Parafuso 5,5x60mm Cab 13 06 N Bucha Ø8mm 06

Ex:

-Se você quer que o painel fique a 30mm do Rack altura do furo = 1150mm.
-Si desea que el panel esté a 30mm del Rack, la altura del agujero es 1150mm.
-If you want the panel 30mm from the rack, the hole height is 1150mm.

22 Passo
Paso
Step **X**

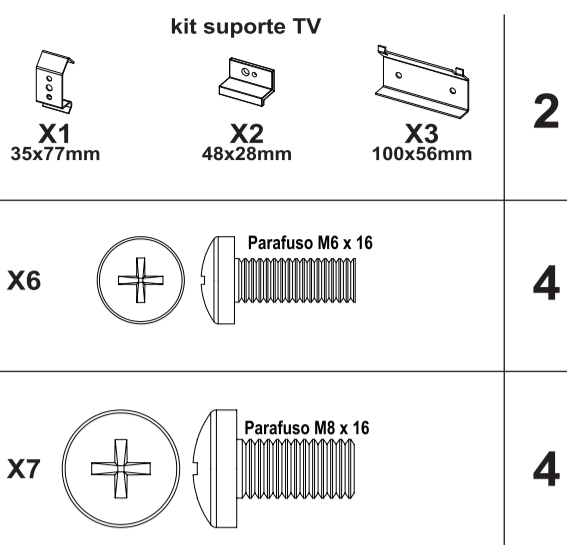

-Para facilitar a fixação do Suporte Universal, enviamos 2 modelos de parafusos que estão de acordo com os padrões mais usados pelos principais fabricantes de TVs LCD / LED / PLASMA / 3D do mercado. Caso nenhum dos 2 modelos se encaixe adequadamente ao seu televisor, adquira o parafuso compatível com sua TV em qualquer loja de ferragens. Para evitar danos à sua TV, não aperte demasiadamente os parafusos.



-Para facilitar la colocación del soporte universal, enviamos 2 modelos de tornillos que cumplen con los estándares más utilizados por los principales fabricantes de televisores. Si ninguno de los modelos se ajusta a su televisor correctamente, compre el tornillo compatible con su televisor en cualquier ferretería. Para evitar daños a su televisor, no apriete demasiado los tornillos.

-To make it easier to attach the TV support, we send 2 screw models that match the most commonly used TVs. If neither model fits your TV properly, purchase the compatible screw from any hardware store. To prevent damage to your TV, do not over tighten the screws.

23 Passo
Paso
Step

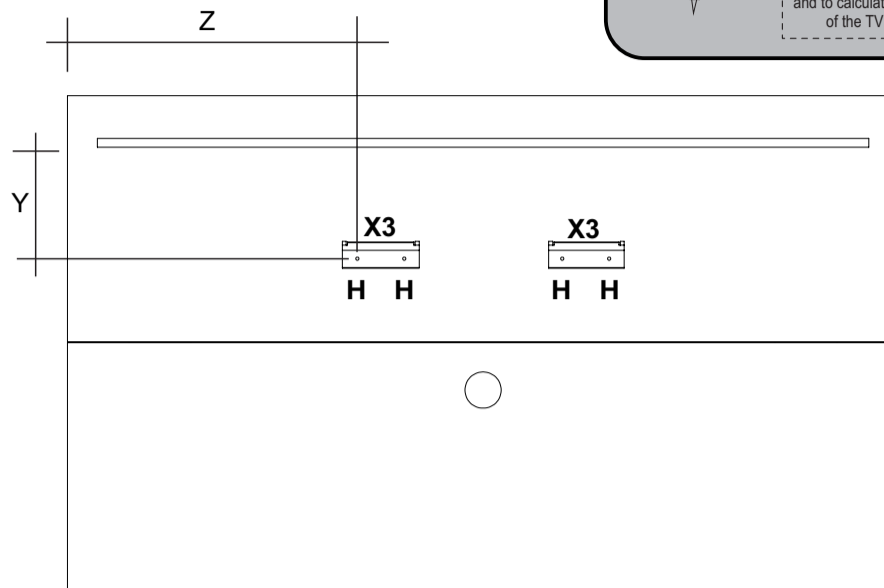

Utilizar a Norma VESA do manual da TV, para calcular a centralização e altura da TV no painel.

Usando el manual del estándar VESA TV, centralización y para calcular la altura del panel de TV.

Using the VESA standard TV's manual, centralization and to calculate the height of the TV panel.



24 Passo
Paso
Step

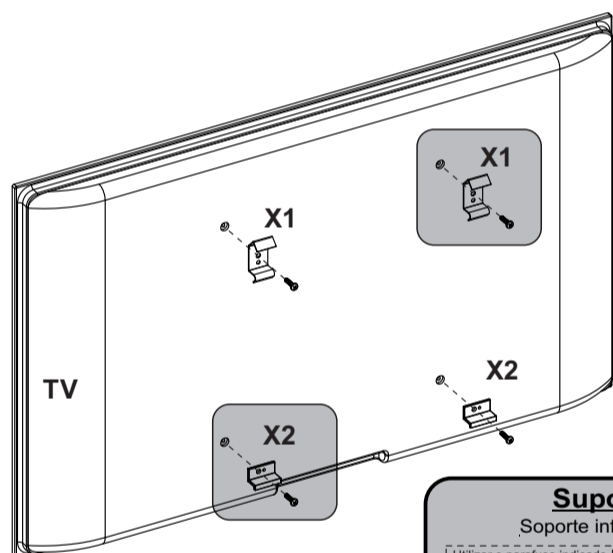

Suporte Superior

Suporte superior / Upper support

Utilizar o parafuso indicado no manual da TV X6,X7(VESA).
Use el tornillo indicado del televisor manual X6,X7(VESA).
Use the screw indicated the TV's manual X6,X7(VESA).

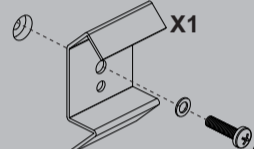

Suporte Inferior

Suporte inferior / Lower support

Utilizar o parafuso indicado no manual da TV X6,X7(VESA).
Use el tornillo indicado del televisor manual X6,X7(VESA).
Use the screw indicated the TV's manual X6,X7(VESA).

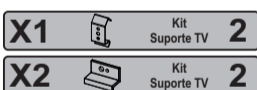
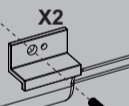

25 Passo
Paso
Step

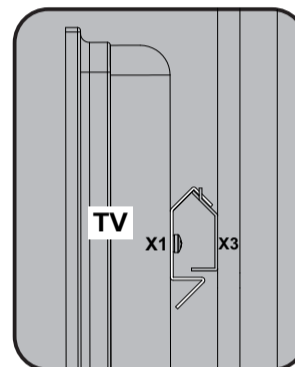
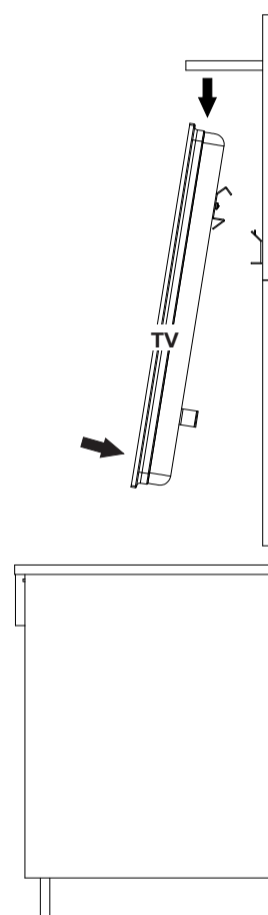

Garantia

Este certificado de Garantia é uma vantagem adicional oferecida ao consumidor, porém para que o mesmo tenha validade é imprescindível que seja apresentada a **NOTA FISCAL** de compra do produto.

Com este produto, a **Artely** tem como objetivo atender plenamente o proprietário-consumidor, proporcionando a garantia na forma aqui estabelecida, pelo período de três meses a partir da data da nota fiscal de compra. A **Artely** restringe a sua responsabilidade à substituição gratuita das peças defeituosas, em caso de defeitos ou avarias devidamente constatados como sendo de fabricação, durante a vigência desta garantia.

A **Artely** declara a garantia nula e sem efeito se o produto for alterado, adulterado, molhado ou consertado e ainda pela prática de montagem inadequada ou mau uso. Também será considerada nula em casos de força maior, como aqueles causados por agentes da Natureza (chuvas, incêndios, excesso de umidade, cupins,...) e eventos externos como objetos arrastados sobre a superfície do móvel (ex.: TV, DVD, aparelho de som, objetos decorativos...).

Para exercer seus direitos de comprador é importante que antes de montar seu produto você leia com atenção as instruções de cada passo do manual de montagem que acompanha o móvel.

Caso o produto não esteja em conformidade, entre em contato com a loja onde efetuou a compra e faça sua reclamação. Para agilizar o seu atendimento, tenha sempre em mãos o manual de montagem com os respectivos números das peças defeituosas, conforme descritas no manual.



Gabarito da Porta / Rack c/ Painel Roma

