

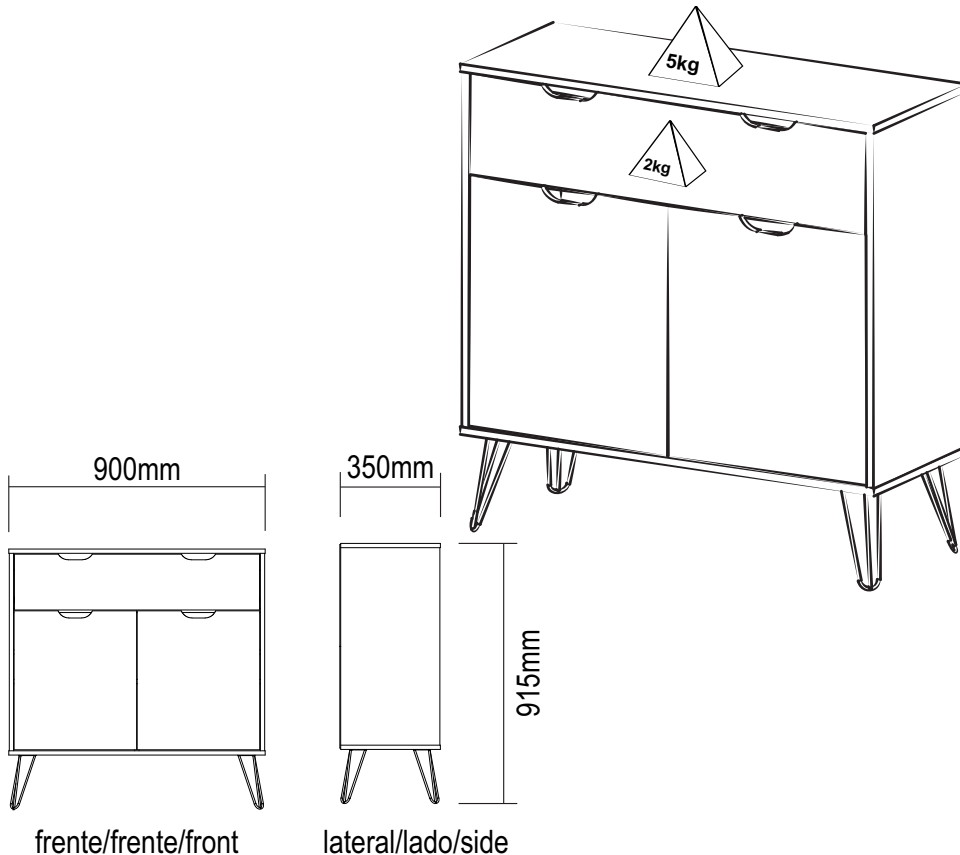

Balcão Estocolmo

Estante Estocolmo / Estocolmo Bookcase
Versão 1.0 / Versión 1.0 / Version 1.0



Conservação e Limpeza - Conservación y Limpieza - Conservation and Cleaning

Não expor o produto ao sol, altas temperaturas e umidade. Não arrastar objetos sobre a superfície do móvel (ex.: TV, DVD, aparelho de som, objetos decorativos...) e manter em local seco e arejado. Para a limpeza, utilizar um pano seco e macio. Não é necessário o uso de materiais abrasivos ou álcool.

No exponga el producto a la luz solar, las altas temperaturas y la humedad. No arrastre los objetos a través de la superficie de la unidad (por ejemplo, TV, DVD, equipo de música, objetos de decoración ...) Mantener en un lugar fresco y seco. Para la limpieza, utilizar un paño seco y suave. El uso de materiales abrasivos o del alcohol no es necesario.

Do not expose the product to sunlight, high temperatures and humidity. Do not drag objects across the surface of the unit (TV, DVD, stereo, decorative objects ...) keep it in a cool dry place. For cleaning, use a dry and soft cloth. Do not use abrasive materials or alcohol.

Garantia

Este certificado de Garantia é uma vantagem adicional oferecida ao consumidor, porém para que o mesmo tenha validade é imprescindível que seja apresentada a NOTA FISCAL de compra do produto.

Com este produto, a **Artely** tem como objetivo atender plenamente o proprietário-consumidor, proporcionando a garantia na forma aqui estabelecida, pelo período de três meses a partir da data da nota fiscal de compra. A **Artely** restringe a sua responsabilidade à substituição gratuita das peças defeituosas, em caso de defeitos ou avarias devidamente constatados como sendo de fabricação, durante a vigência desta garantia.

A **Artely** declara a garantia nula e sem efeito se o produto for alterado, adulterado, molhado ou consertado e ainda pela prática de montagem inadequada ou mau uso. Também será considerada nula em casos de força maior, como aqueles causados por agentes da Natureza (chuvas, incêndios, excesso de umidade, cupins,...) e eventos externos como objetos arrastados sobre a superfície do móvel (ex.: TV, DVD, aparelho de som, objetos decorativos...).

Para exercer seus direitos de comprador é importante que antes de montar seu produto você leia com atenção as instruções de cada passo do manual de montagem que acompanha o móvel.

Caso o produto não esteja em conformidade, entre em contato com a loja onde efetuou a compra e faça sua reclamação, apontando os defeitos técnicos observados. Para agilizar o seu atendimento, tenha sempre em mãos o manual de montagem com os respectivos números das peças defeituosas, conforme descritas no manual.

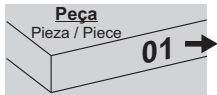



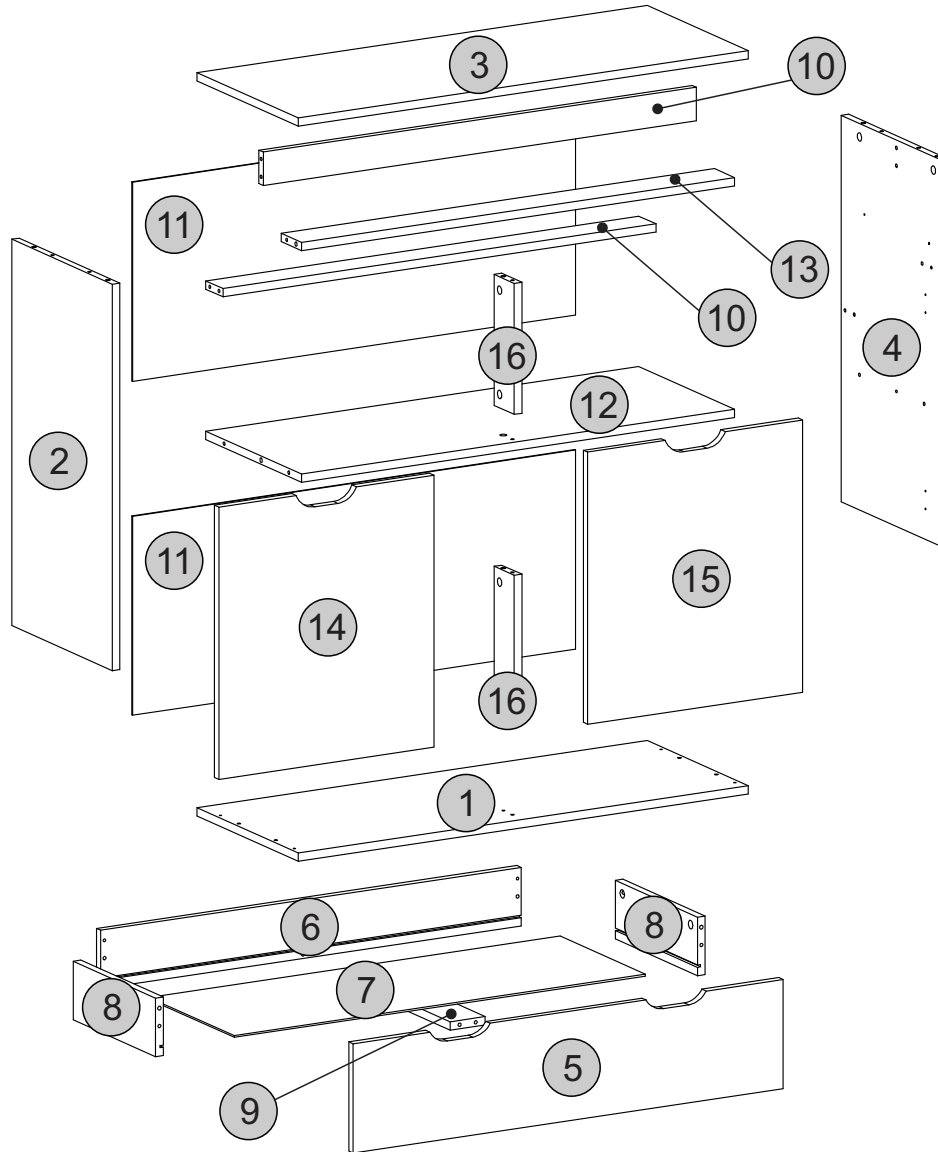
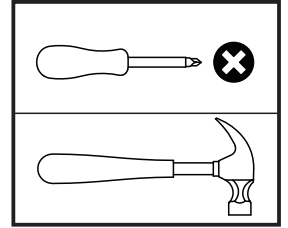





- O número na borda da peça corresponde ao manual.
- Para retirada do número usar Lustra-Móveis, Alcool em Gel ou Borracha.
- El número en el borde de la pieza coincide con el manual.
- Use una goma de borrar blanca, alcohol en gel o lustrador para muebles para eliminar los números.
- The number on the edge of the piece matches the manual.
- Use a White eraser, Alcohol Gel or Furniture Polish to remove the numbers.

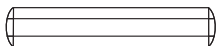
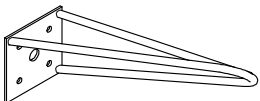
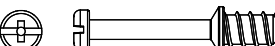

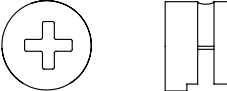
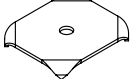
Descrição	Descripción	Description	Qty
1-Base (900x350x15mm)	1-Base	1-Base	1
2-Lateral esquerda (693x348x15mm)	2-Lado izquierdo	2-Left side	1
3-Tampo (900x350x15mm)	3-Tapa	3-Top	1
4-Lateral direita (693x348x15mm)	4-Lado derecho	4-Right side	1
5-Frente gaveta (860x196x15mm)	5-Cajón frontal	5-Drawer Front	1
6-Traseira gaveta (841x105x15mm)	6-Cajón traseiro	6-Drawer back	1
7-Fundo gaveta (822x295x3mm)	7-Cajón fundo	7-Drawer botton	1
8-Lateral gaveta (285x105x15mm)	8-Cajón lado	8-Drawer side	2
9-Travessa gaveta (285x70x15mm)	9-Cajón travesaño	9-Drawer crosspiece	1
10-Travessa traseira (866x60x15mm)	10-Travesaño traseiro	10-Crosspiece back	2
11-Traseira (886x357x3mm)	11-Traseiro	11-Back	2
12-Prateleira (866x332x15mm)	12-Anaque	12-Shelf	1
13-Travessa frontal (866x70x15mm)	13-Travesaño frontal	13-Front crosspiece	1
14-Porta esquerda (488x430x15mm)	14-Puerta izquierdo	14-Left door	1
15-Porta direita (488x430x14mm)	15-Puerta derecho	15-Right door	1
16-Travessa divisão (235x70x15mm)	16-División	16-Division	2

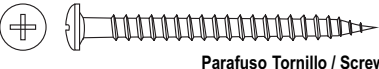
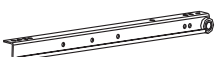
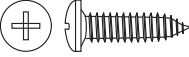
Lista de Materiais

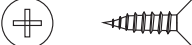
Lista de Materiales/ Hardware List

A		Cavilha / Tarugo / Dowel Ø6x30mm	34	I		Pé Metal Foot Metal / Pie de Metal	04
B		Minifix / Minifix / Minifix Ø7x30mm	14	J		Prego Nail / Clavo 8x8	31
C		Tambor / Tambor / Minifix Cam Ø15x12mm	16	K		Fixador / Fijador / Fixer	05
D		Tapa furo adesivo / Adesivo / Hole Cover Ø18mm	12	L		Haste Dupla Minifix / Minifix Doble Varilla / Double Rod Minifix Ø7x60mm	01
E		Parafuso Tornillo / Screw Ø3,5x40mm CP	04	M		Corrediça / Guia / Slider 300mm	02
F		Parafuso Tornillo / Screw Ø4x14mm CP	32	N		Corrediça / Guia / Slider 300mm	02
G		Calço Dobradiça Cuna / Chock	04	O		Parafuso / Tornillo / Screw Ø3,5x12mm CC	08
H		Dobradiça Bisagra / Hinge	04				

DICAS PARA FIXAR MINIFIX

TIP TO FASTEN THE MINIFIX
PISTA PARA ARREGLAR EL MINIFIX

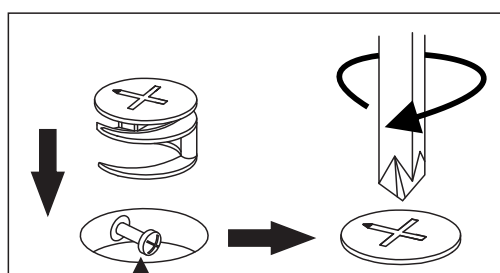

Cabeça do parafuso precisa estar no centro
La cabeza del tornillo debe estar en el centro
Screw head has to be in the center

Parafuso Minifix

Tornillo minifix/Minifix screw

Fixe o parafuso até o ressalto encostar na superfície da peça (veja o exemplo abaixo).

Tighten the screw until its overhang part lean on the piece surface (see the example below).

Fije el tornillo hasta que su parte sobressaliente toque la superficie de la pieza (vea el ejemplo abajo).

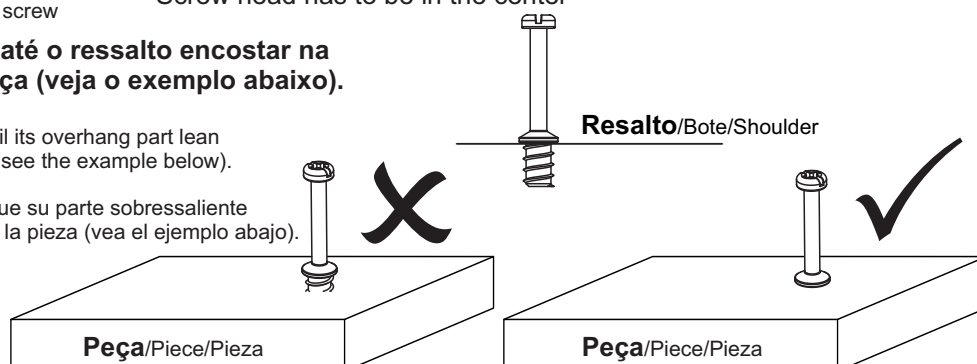

Passo 1

Paso/Step

PEÇA
Pieza/Piece

1 - BASE x1

3 - TAMPO x1

FERRAGEM
Herraje/Hardware

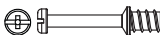
B  05

FERRAMENTA
Herramienta/Tool

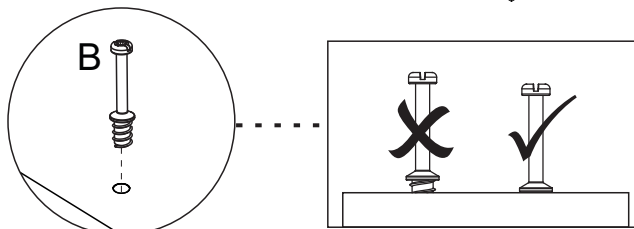
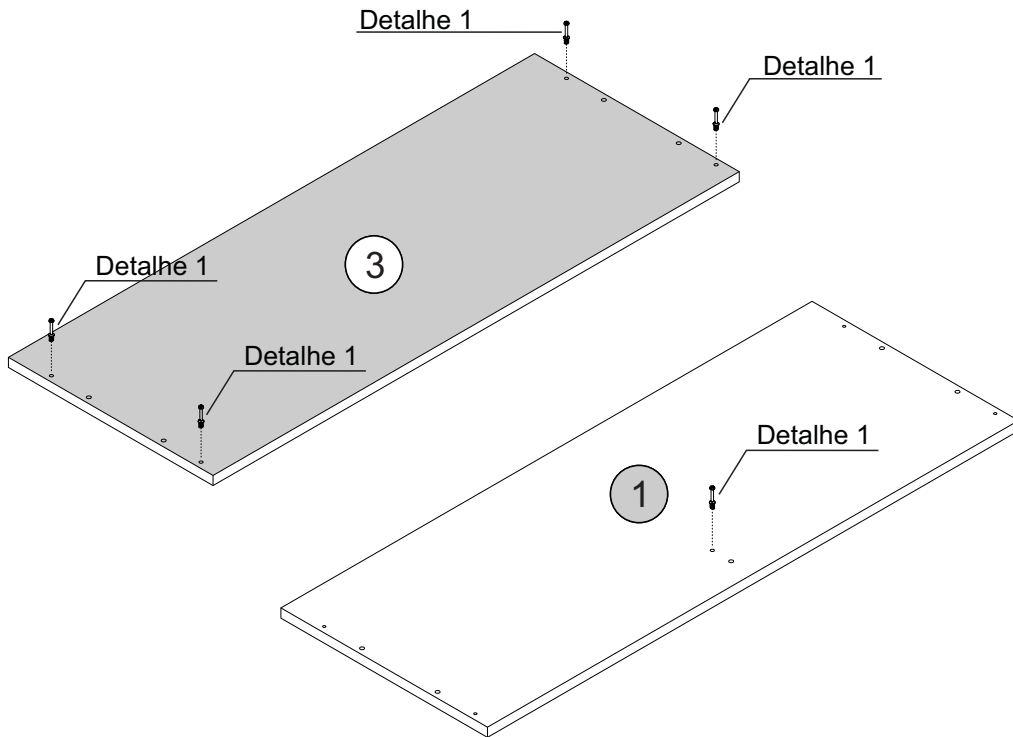
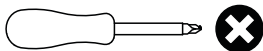

Detalhe 1
Detalle/Detail

Passo 2

Paso/Step

PEÇA
Pieza/Piece

12 - PRATELEIRA x1

FERRAGEM
Herraje/Hardware

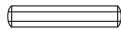
A  04

FERRAMENTA
Herramienta/Tool

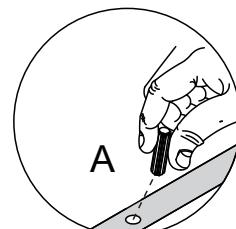
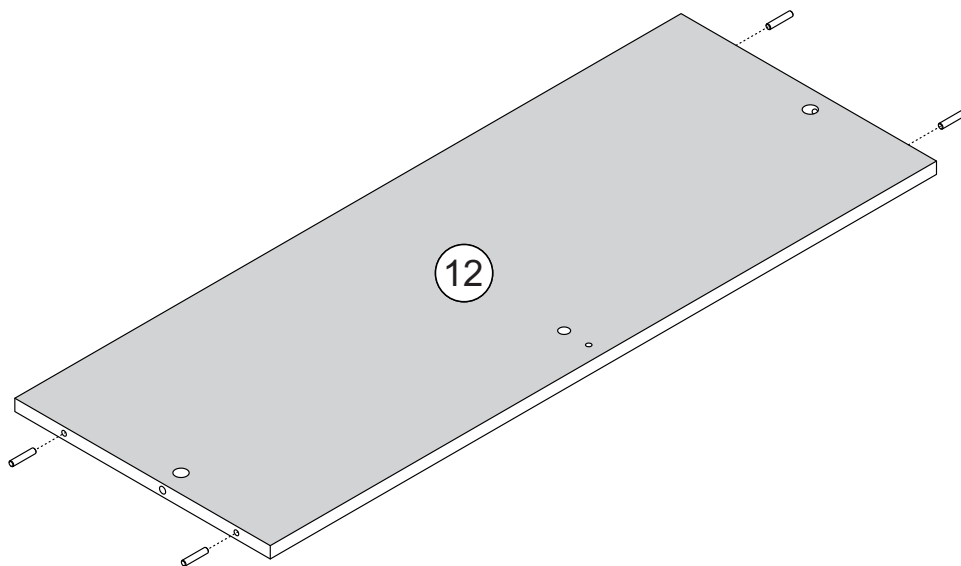
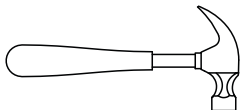

Detalhe 2
Detalle/Detalle

Passo 3

Paso/Step

PEÇA

Pieza/Piece

2 - LATERAL ESQUERDA x1

FERRAGEM

Herraje/Hardware

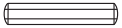
A  04

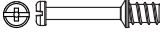
B  02

F  04

G  02

N  01

O  02

FERRAMENTA

Herramienta/Tool

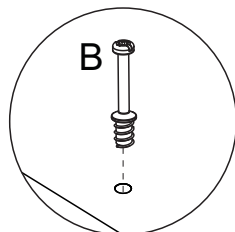
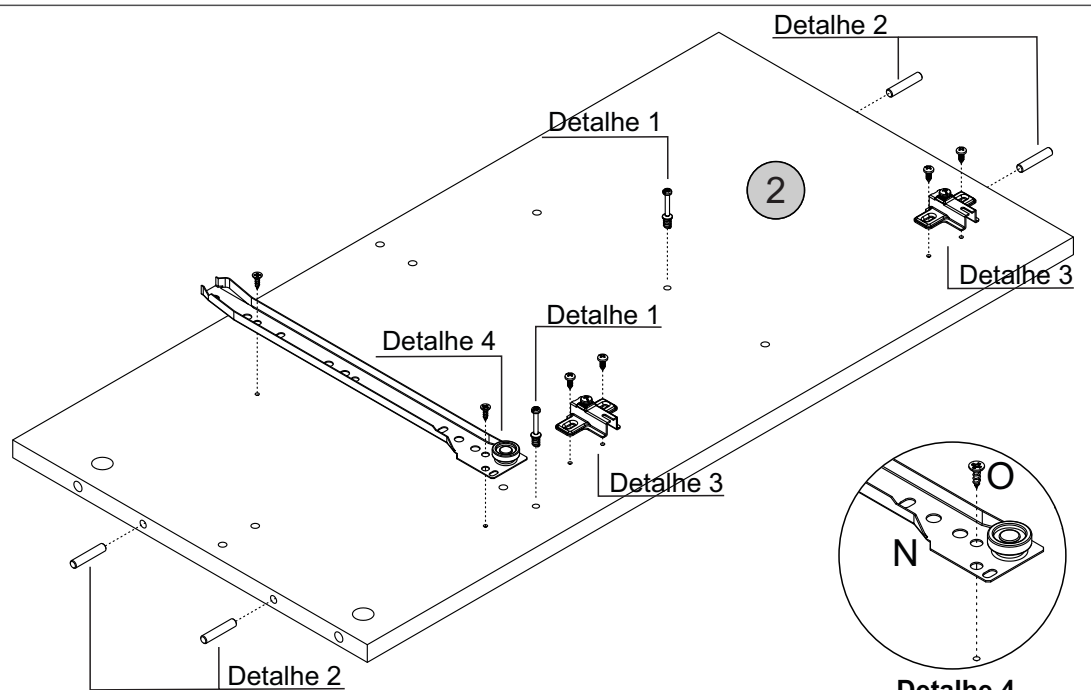
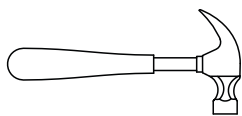
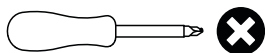

Detalhe 1
Detail/Detalle

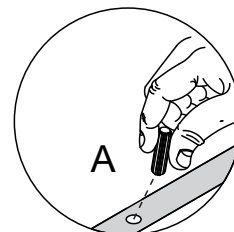
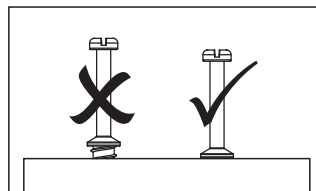

Detalhe 2
Detail/Detalle

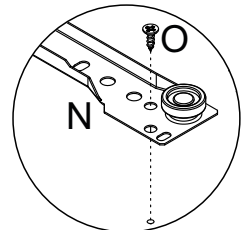

Detalhe 4
Detail/Detalle

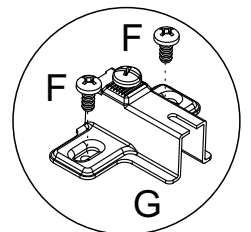

Detalhe 3
Detail/Detalle

Passo 4

Paso/Step

PEÇA

Pieza/Piece

4 - LATERAL DIREITA x1

FERRAGEM

Herraje/Hardware

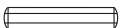
A  04

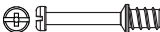
B  02

F  04

G  02

N  01

O  02

FERRAMENTA

Herramienta/Tool

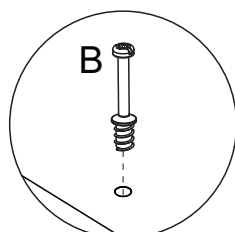
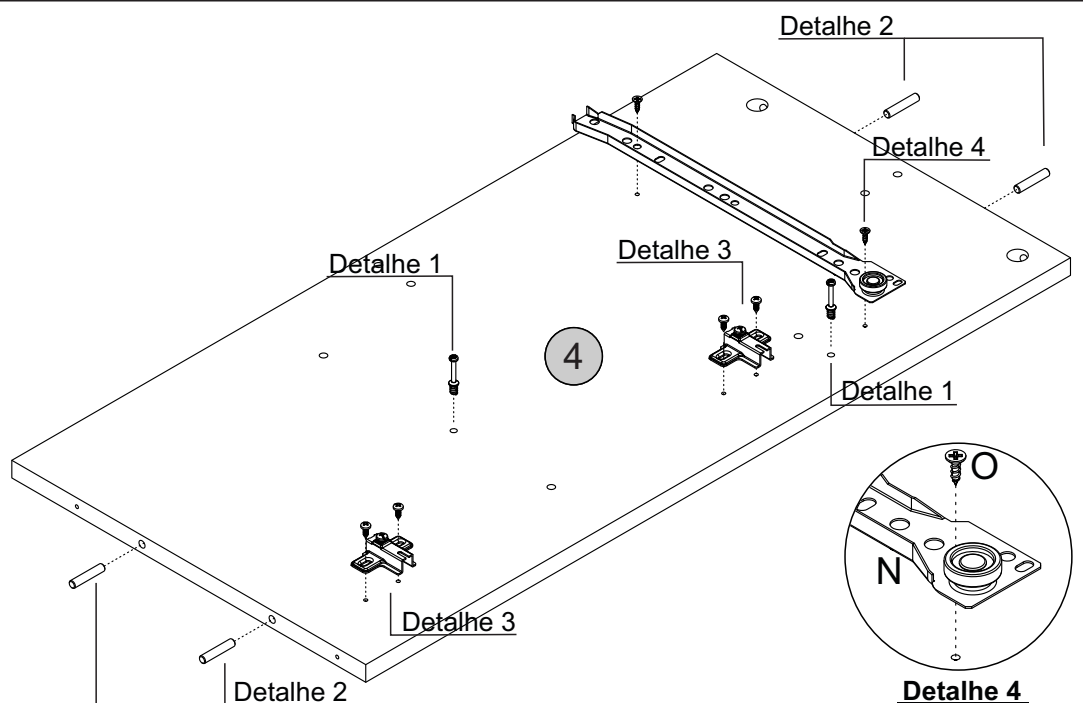
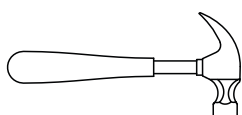
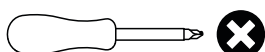

Detalhe 1
Detail/Detalle

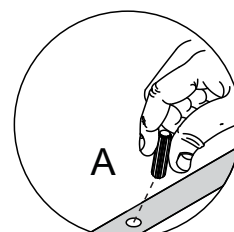
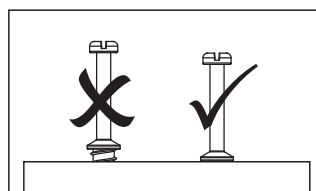

Detalhe 2
Detail/Detalle

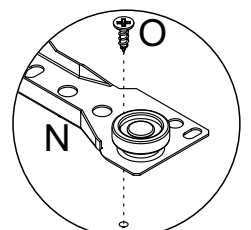

Detalhe 4
Detail/Detalle

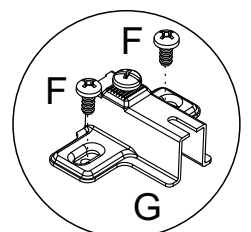

Detalhe 3
Detail/Detalle

Passo 5

Paso/Step

PEÇA

Pieza/Piece

14 - PORTA ESQUERDA x1

15 - PORTA DIREITA x1

FERRAGEM

Herraje/Hardware

F  08

H  04

FERRAMENTA

Herramienta/Tool

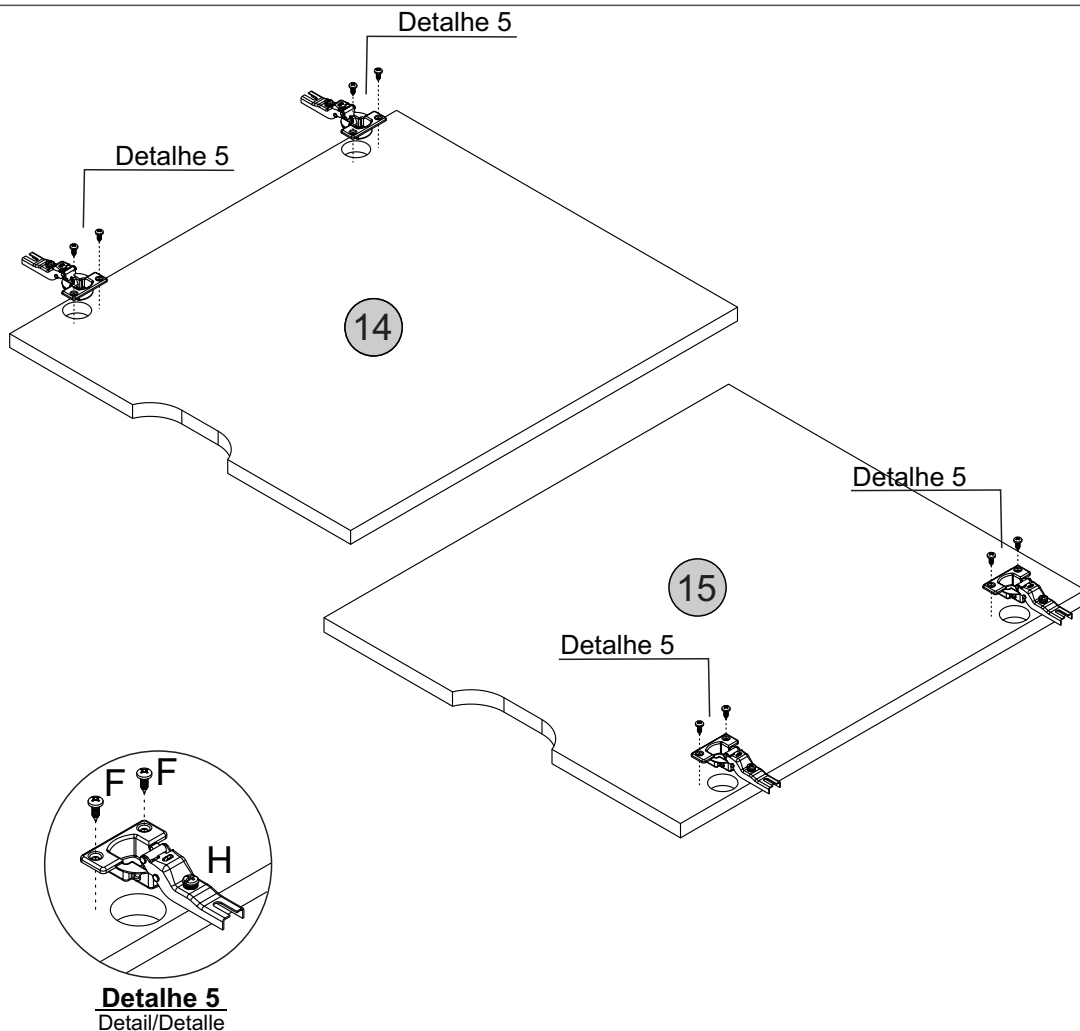
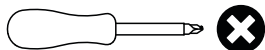

Passo 6

Paso/Step

PEÇA

Pieza/Piece

10 - TRAVESSA TRASEIRA x2

13 - TRAVESSA FRONTAL x1

16 - TRAVESSA DIVISÃO x2

FERRAGEM

Herraje/Hardware

A  14

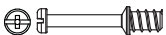
B  01

FERRAMENTA

Herramienta/Tool

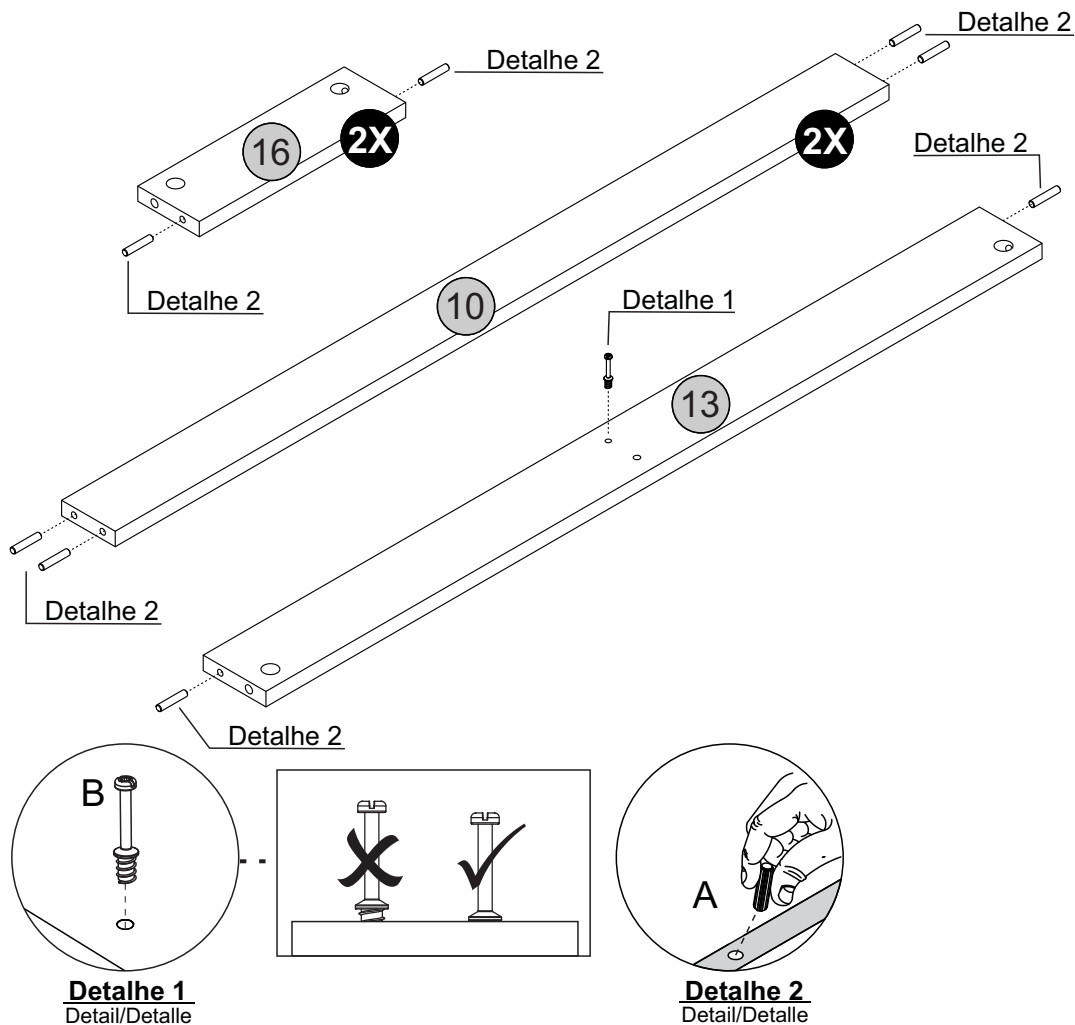
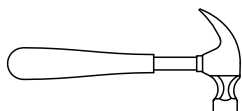
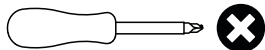

Passo 7

Paso/Step

PEÇA

Pieza/Piece

4 - LATERAL DIREITA x1

12 - PRATELEIRA x1

FERRAGEM

Herraje/Hardware

C   01

FERRAMENTA

Herramienta/Tool

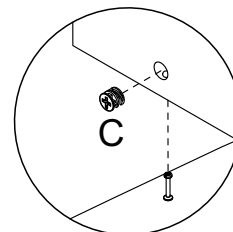
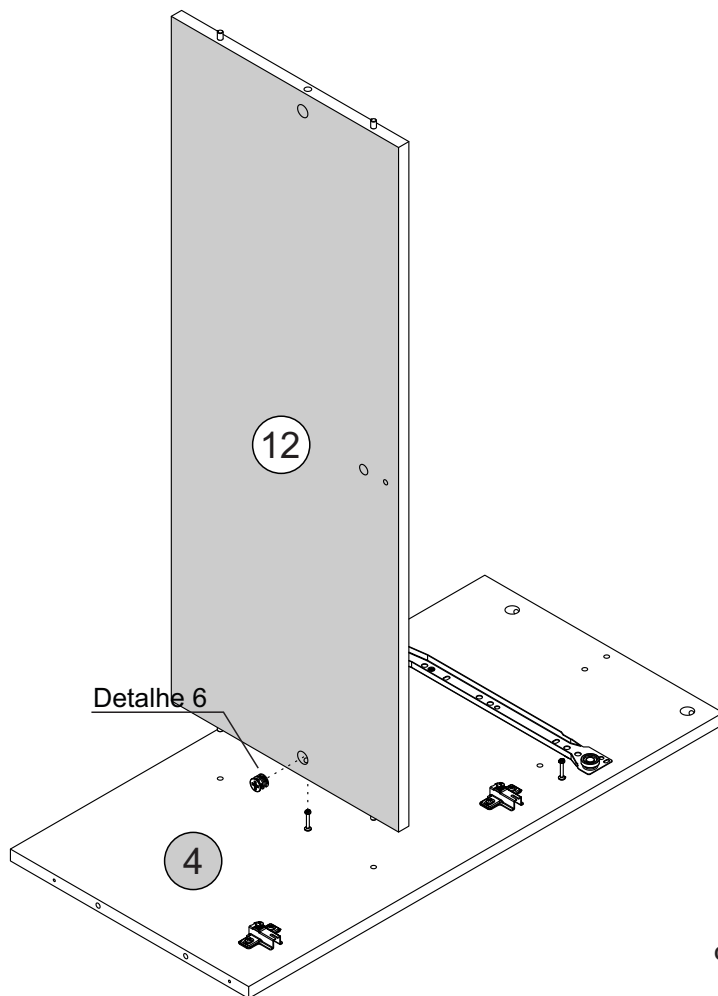
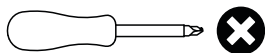

Detalhe 6
Detalle/Detail

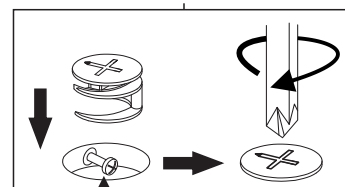

Cabeça do parafuso precisa estar no centro
La cabeza del tornillo debe estar en el centro
Screw head has to be in the center

Passo 8

Paso/Step

PEÇA

Pieza/Piece

13 - TRAVESSA FRONTAL x1

16 - TRAVESSA DIVISÃO x1

FERRAGEM

Herraje/Hardware

C   01

D  01

FERRAMENTA

Herramienta/Tool

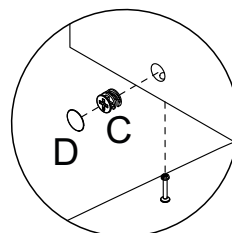
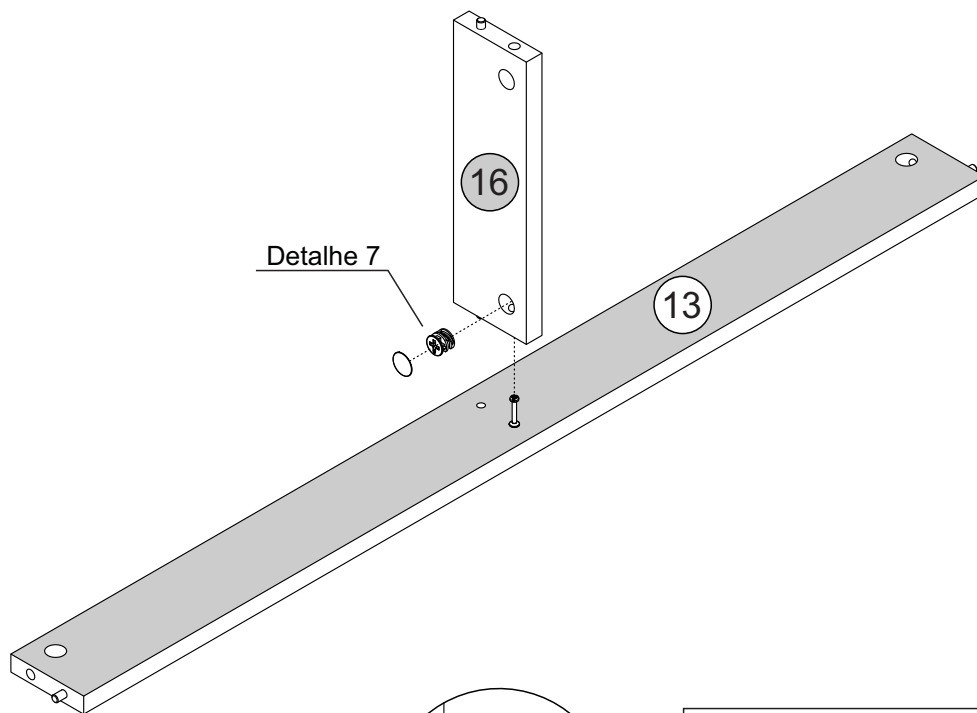
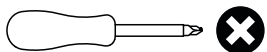

Detalhe 7
Detalle/Detail

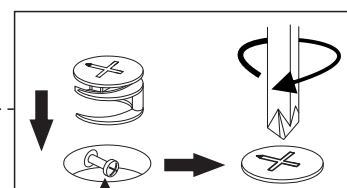

Cabeça do parafuso precisa estar no centro
La cabeza del tornillo debe estar en el centro
Screw head has to be in the center

Passo 9

Paso/Step

PEÇA

Pieza/Piece

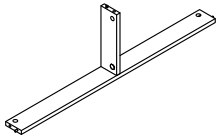
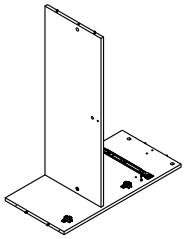

FERRAGEM

Herraje/Hardware

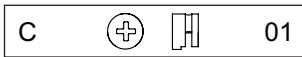

FERRAMENTA

Herramienta/Tool

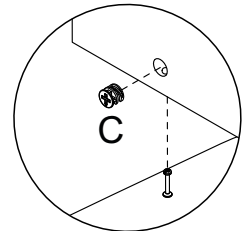
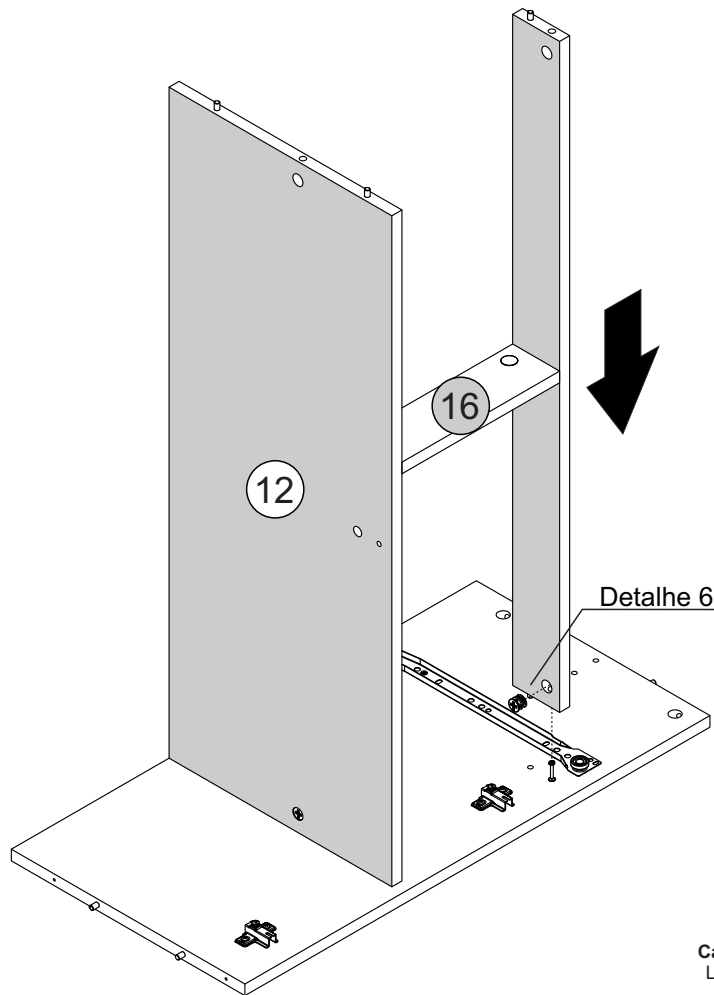
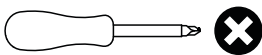

Detalhe 6
Detalle/Detail

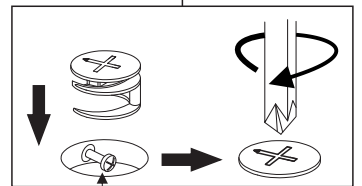

Cabeça do parafuso precisa estar no centro
La cabeza del tornillo debe estar en el centro
Screw head has to be in the center

Passo 10

Paso/Step

PEÇA

Pieza/Piece

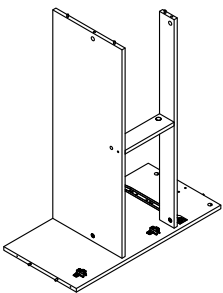

10 - TRAVESSA TRASEIRA x2

FERRAGEM

Herraje/Hardware

FERRAMENTA

Herramienta/Tool

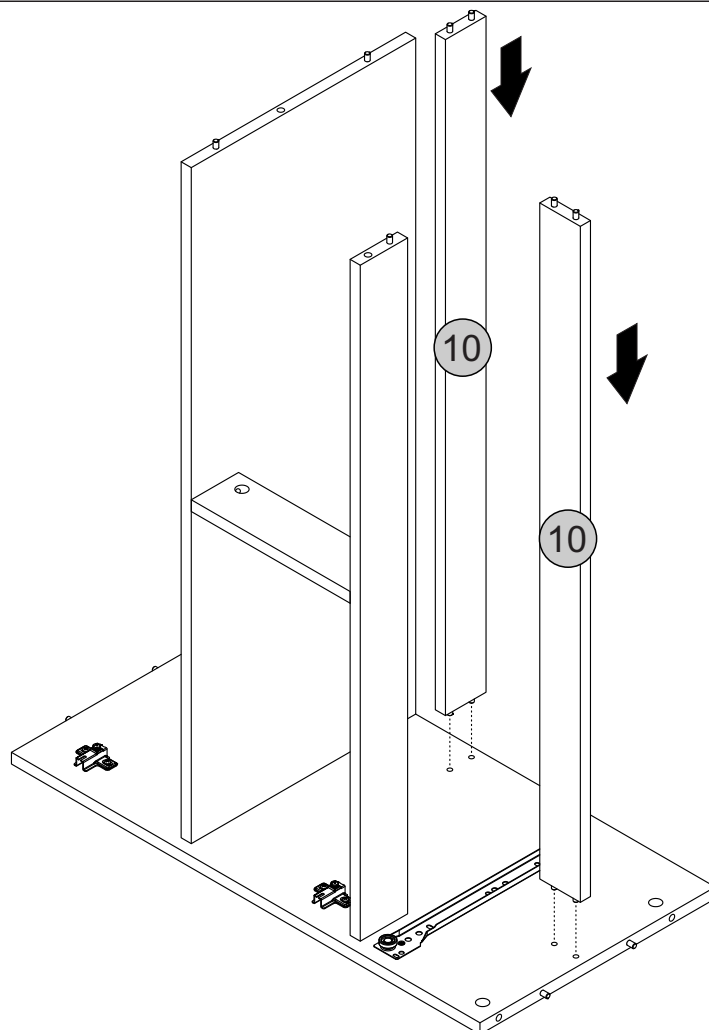

Passo 11

Paso/Step

PEÇA

Pieza/Piece

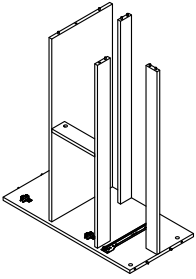

2 - LATERAL ESQUERDA x1

FERRAGEM

Herraje/Hardware

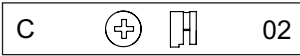

FERRAMENTA

Herramienta/Tool

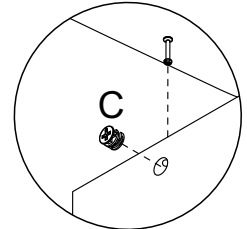
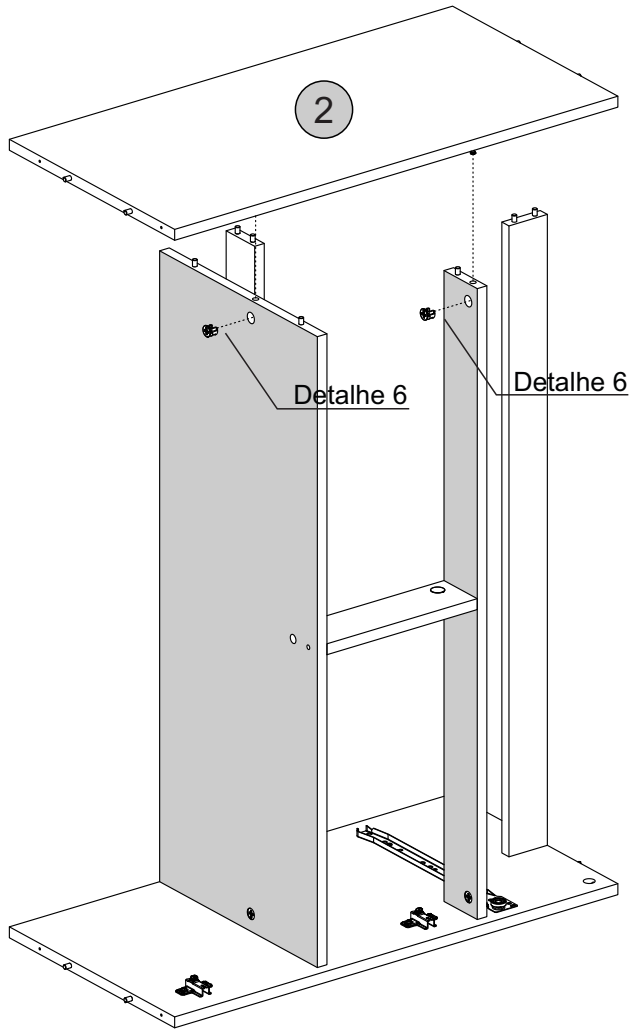
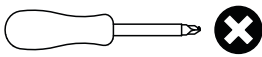

Detalhe 6
Detalle/Detail

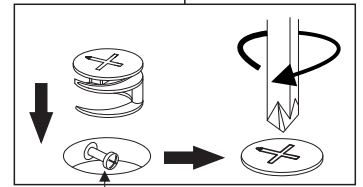

Cabeça do parafuso precisa estar no centro
La cabeza del tornillo debe estar en el centro
Screw head has to be in the center

Passo 12

Paso/Step

PEÇA

Pieza/Piece

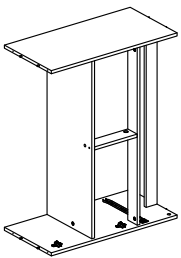

16 - TRAVESSA DIVISÃO x1

FERRAGEM

Herraje/Hardware

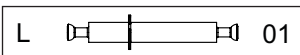
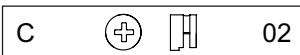

FERRAMENTA

Herramienta/Tool

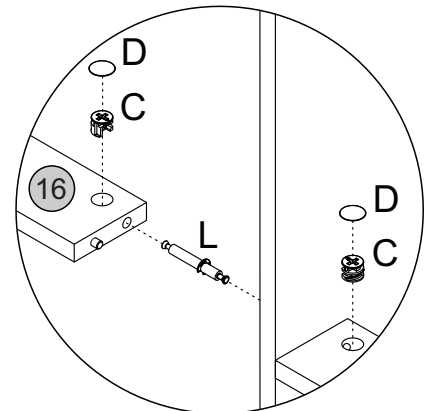
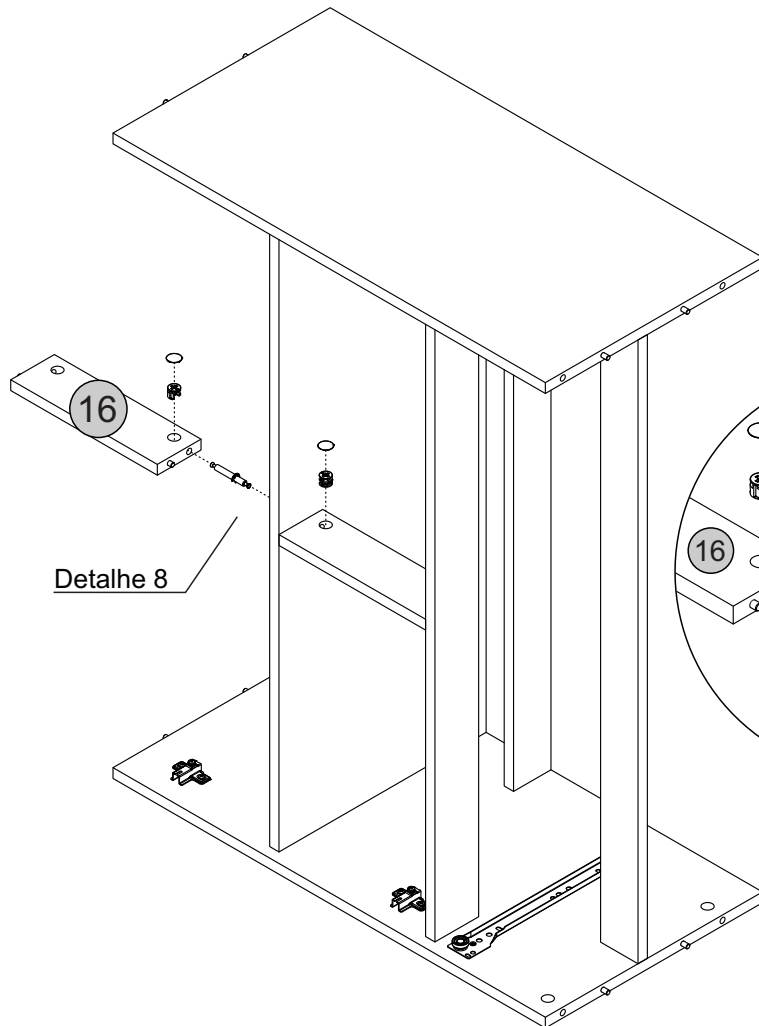
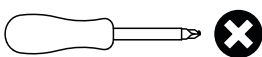

Detalhe 8
Detalle/Detail

Passo 13

Paso/Step

PEÇA
Pieza/Piece

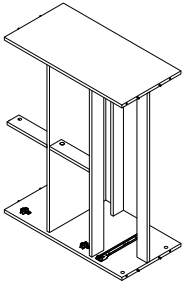

1 - BASE x1

FERRAGEM
Herraje/Hardware

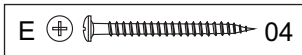
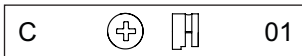

FERRAMENTA
Herramienta/Tool

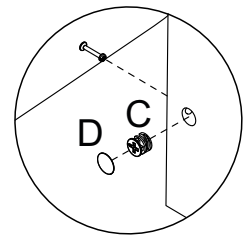
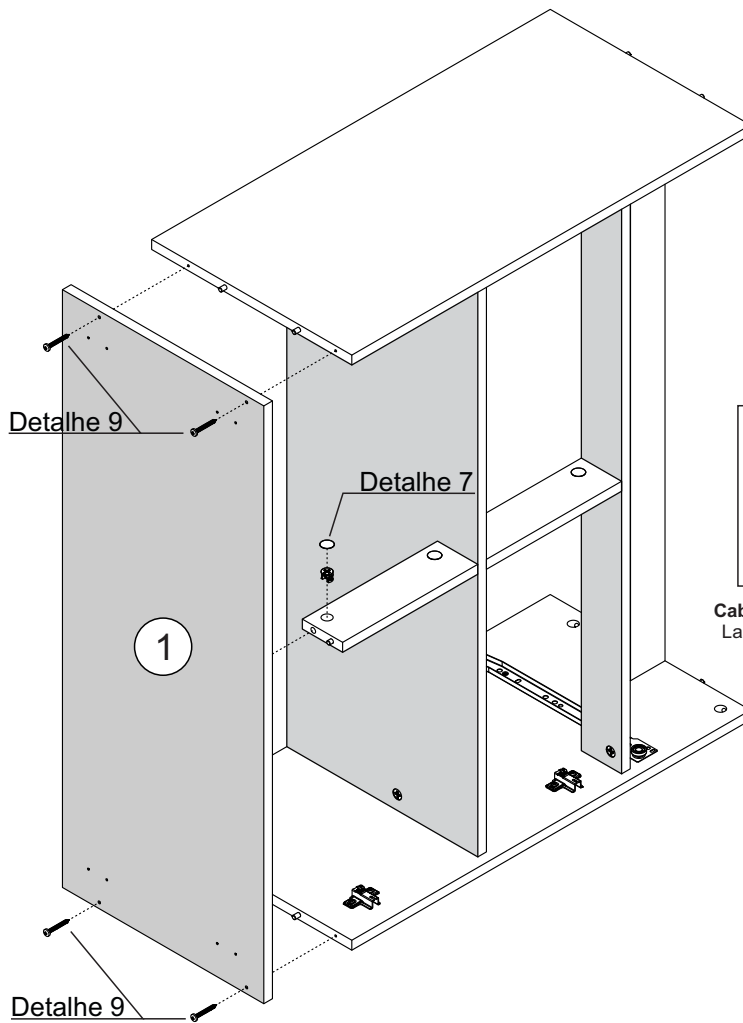
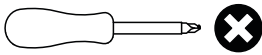

Detalhe 7
Detalle/Detail

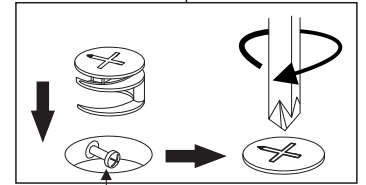

Cabeça do parafuso precisa estar no centro
La cabeza del tornillo debe estar en el centro
Screw head has to be in the center

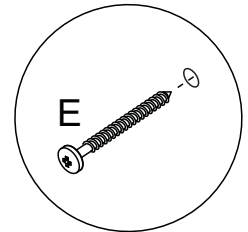

Detalhe 9
Detalle/Detail

Passo 14

Paso/Step

PEÇA
Pieza/Piece

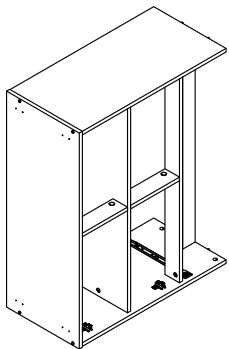

3 - TAMPO x1

FERRAGEM
Herraje/Hardware

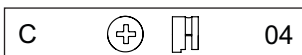

FERRAMENTA
Herramienta/Tool

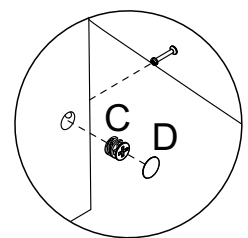
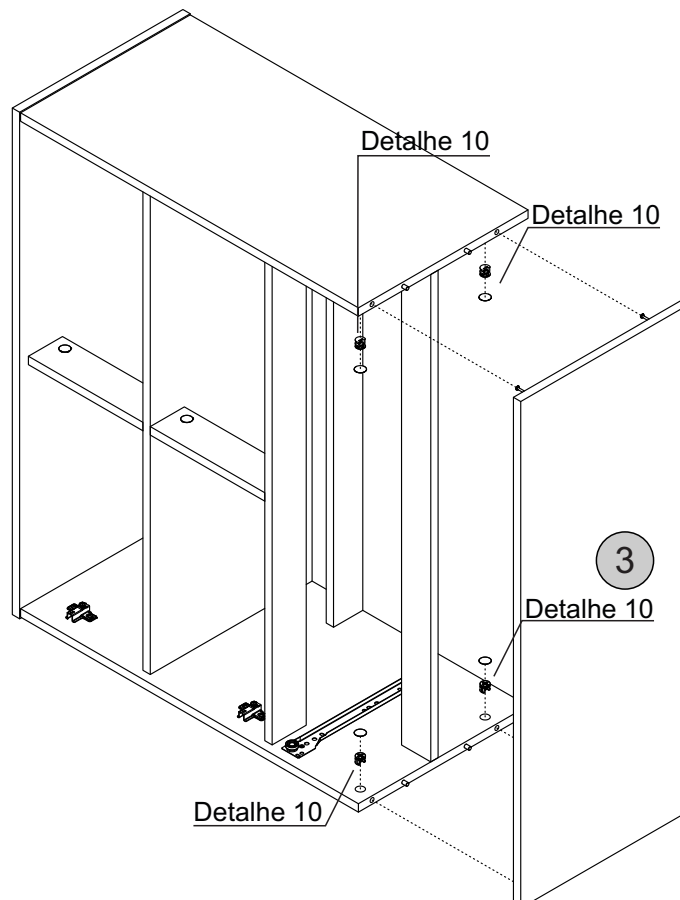
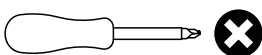

Detalhe 7
Detalle/Detail

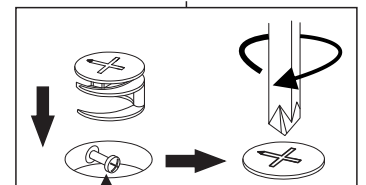

Cabeça do parafuso precisa estar no centro
La cabeza del tornillo debe estar en el centro
Screw head has to be in the center

Passo 15

Paso/Step

PEÇA
Pieza/Piece

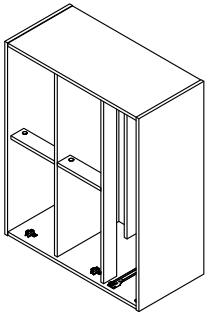

11 - TRASEIRA x2

FERRAGEM
Herraje/Hardware

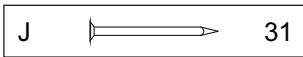

FERRAMENTA
Herramienta/Tool

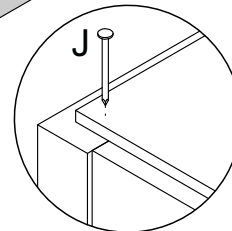
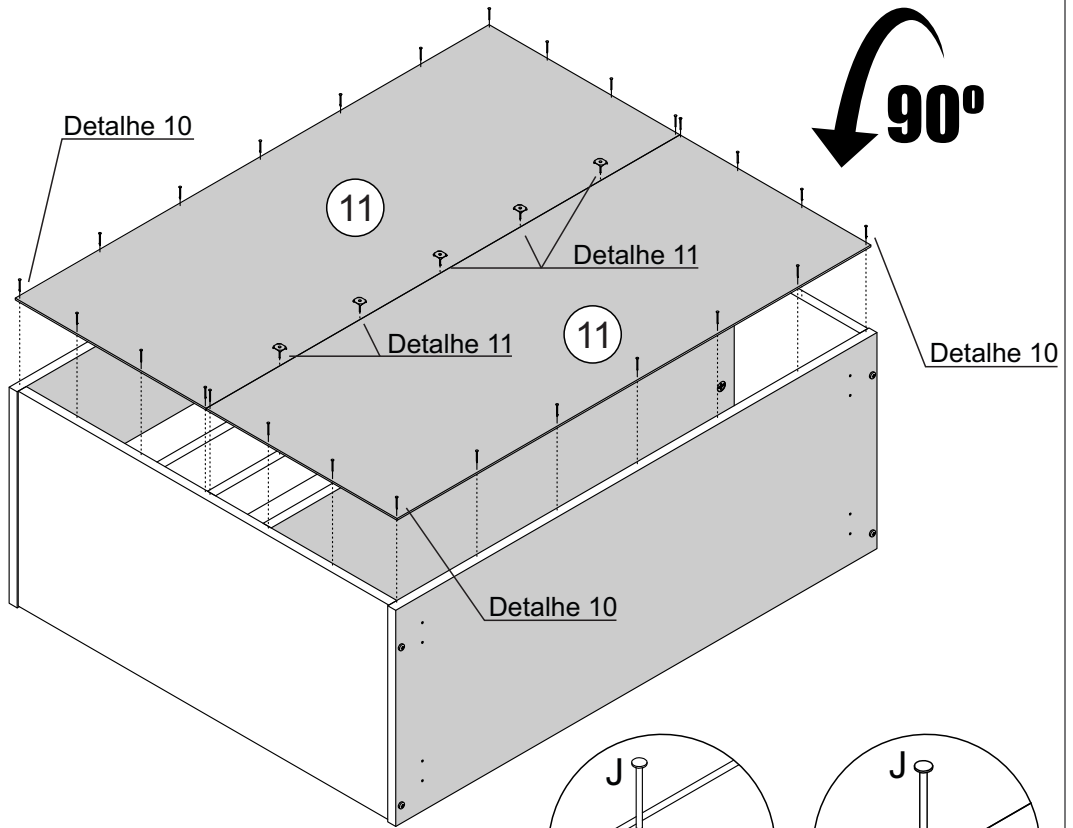
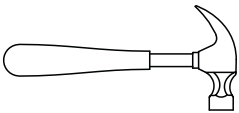

Detalhe 10
Detalle/Detail

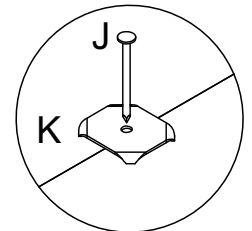

Detalhe 11
Detalle/Detail

Passo 16

Paso/Step

PEÇA
Pieza/Piece

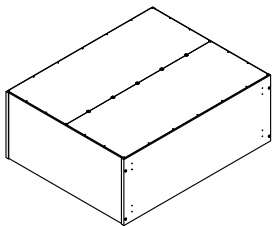

FERRAGEM
Herraje/Hardware

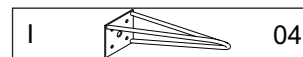
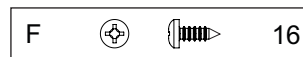

FERRAMENTA
Herramienta/Tool

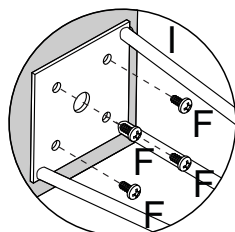
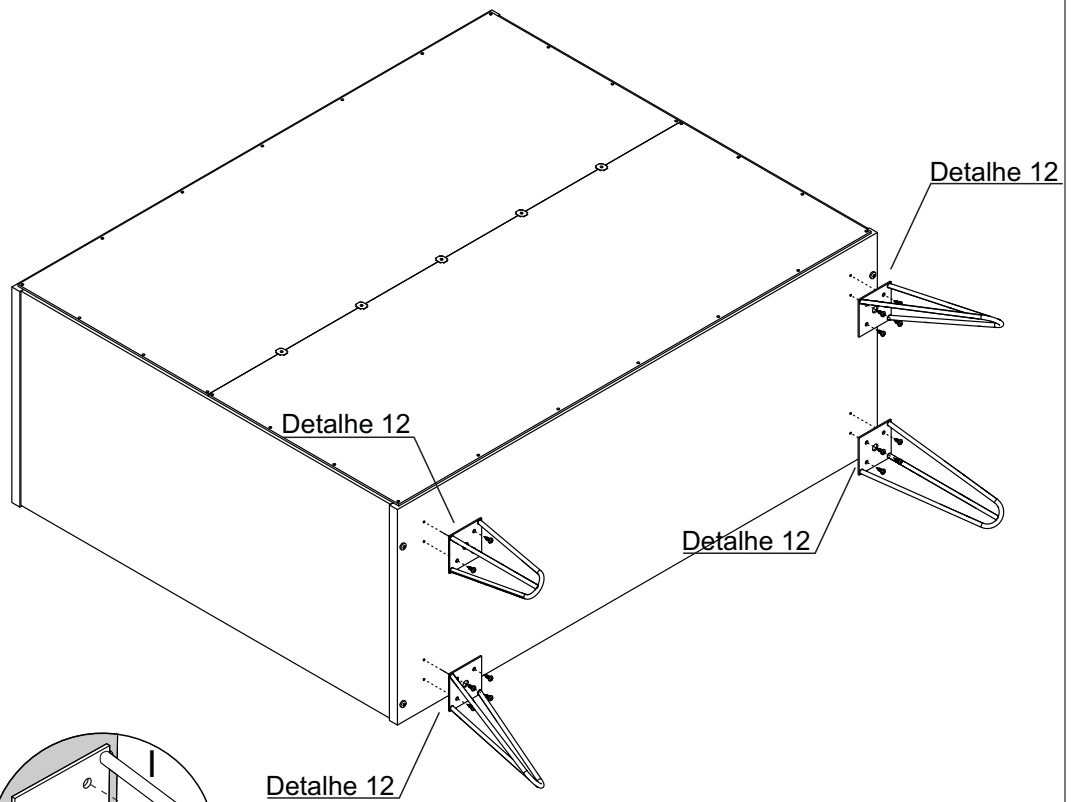
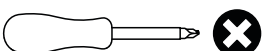

Detalhe 12
Detalle/Detail

Passo 17

Paso/Step

PEÇA
Pieza/Piece

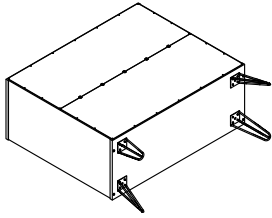

14 - PORTA ESQUERDA x2

15 - PORTA DIREITA x2

FERRAGEM
Herraje/Hardware

FERRAMENTA
Herramienta/Tool

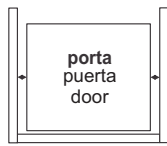
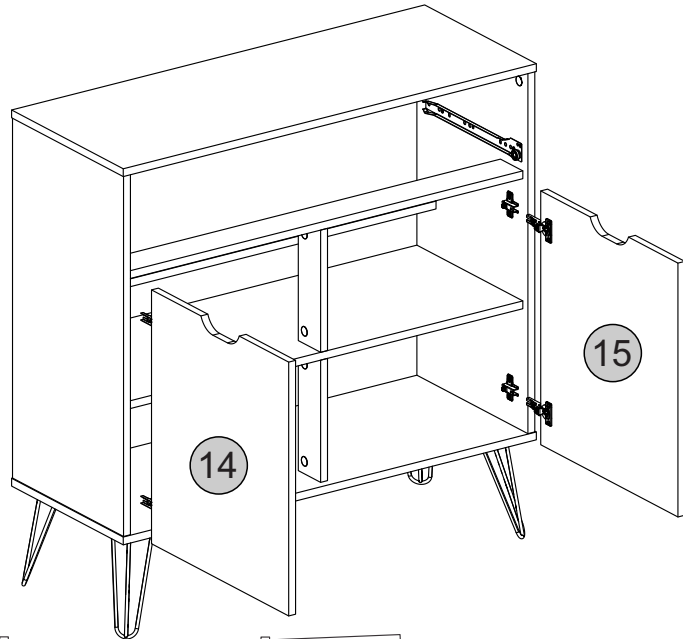
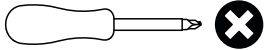

Ajuste de Largura
Ajuste de ancho
Width Adjustment

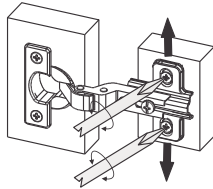

Ajuste Interno
Ajuste Interno
Internal Adjustment

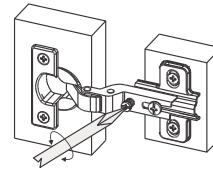

Ajuste de Profundidade
Ajuste de profundidad
Depth Adjustment

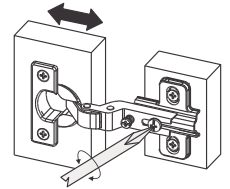

Passo 18

Paso/Step

PEÇA
Pieza/Pieza

5 - FRENTE GAVETA x1

6 - TRASEIRA GAVETA x1

8 - LATERAL GAVETA x2

9 - TRAVESSA GAVETA x1

FERRAGEM
Hardware/Herraje

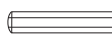
A  08

B  04

FERRAMENTA
Tool/Herramienta

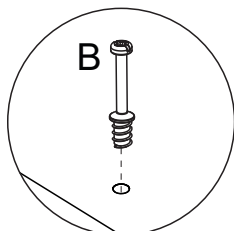
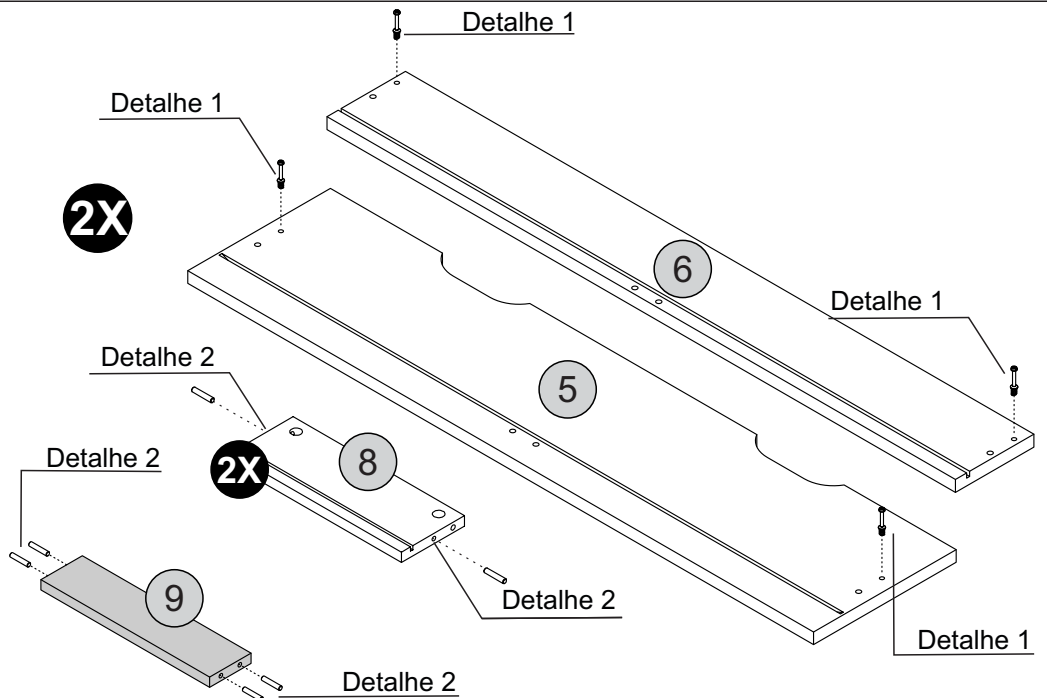
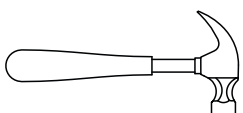
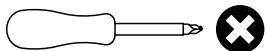

Detalhe 1
Detail/Detalle

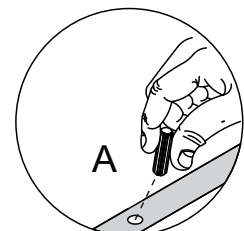
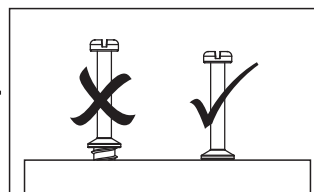

Detalhe 2
Detail/Detalle

Passo 19

Paso/Step

PEÇA
Pieza/Piece

5 - FRENTE GAVETA x1

7 - FUNDO GAVETA x1

8 - LATERAL GAVETA x2

FERRAGEM
Herraje/Hardware

C   02

D  02

FERRAMENTA
Herramienta/Tool

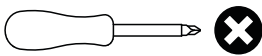

Passo 20



Paso/Step

PEÇA
Pieza/Pieza

6 - TRASEIRA GAVETA x1

9 - TRAVESSA GAVETA x1

FERRAGEM
Hardware/Herraje

C   02

D  02

FERRAMENTA
Herramienta/Tool

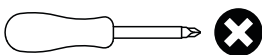

Passo 21

Paso/Step

PEÇA
Pieza/Piece

FERRAGEM
Herraje/Hardware

N  02

O  04

FERRAMENTA
Herramienta/Tool

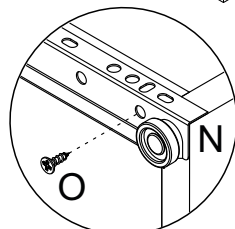
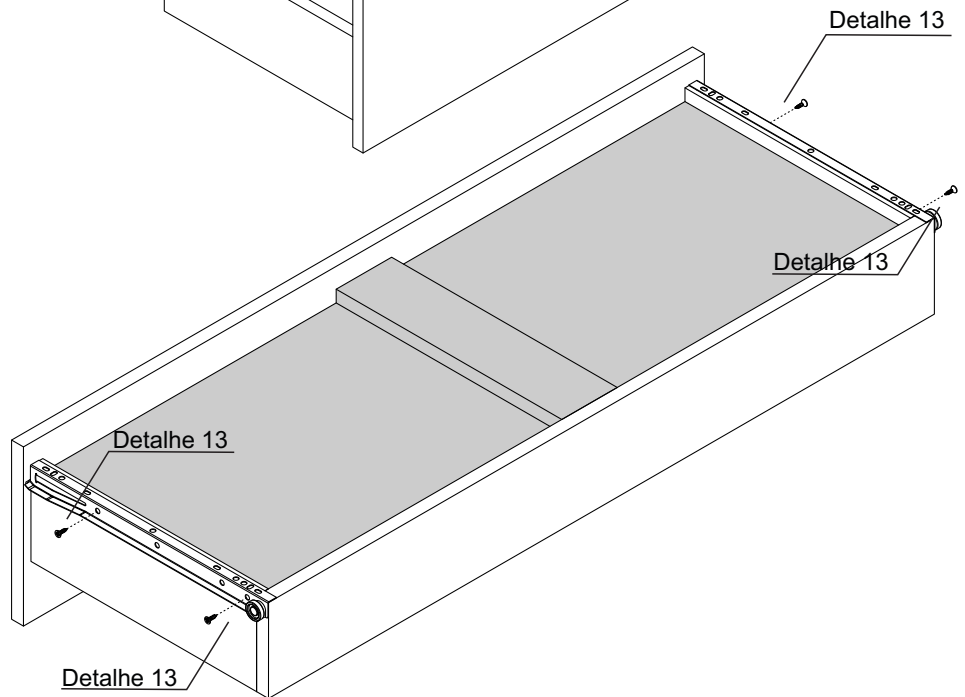
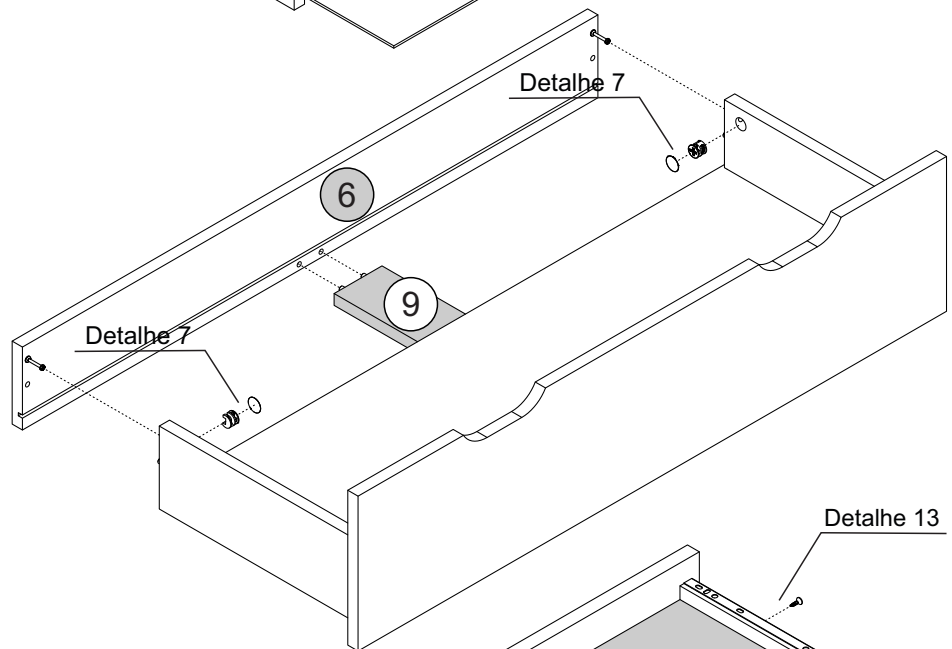
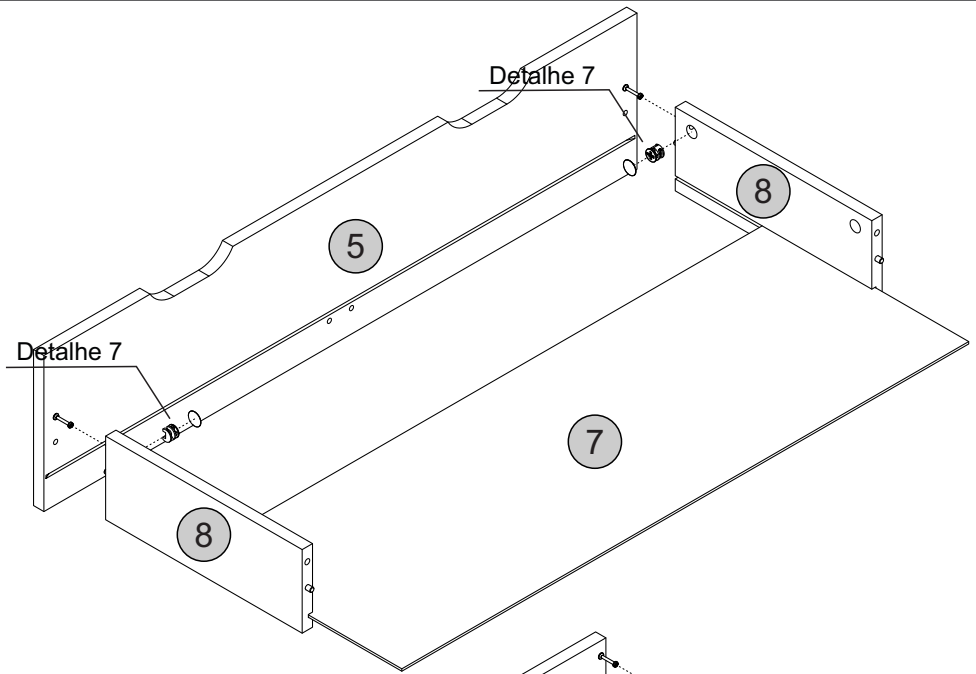
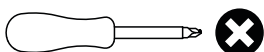

Detalhe 13
Detail/Detalle

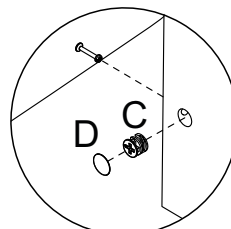

Detalhe 7
Detalle/Detail

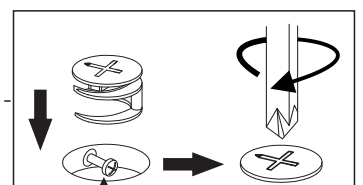

Cabeça do parafuso precisa estar no centro
La cabeza del tornillo debe estar en el centro
Screw head has to be in the center

Passo 22

Paso/Step

PEÇA
Pieza/Piece

FERRAGEM
Herraje/Hardware

FERRAMENTA
Herramienta/Tool

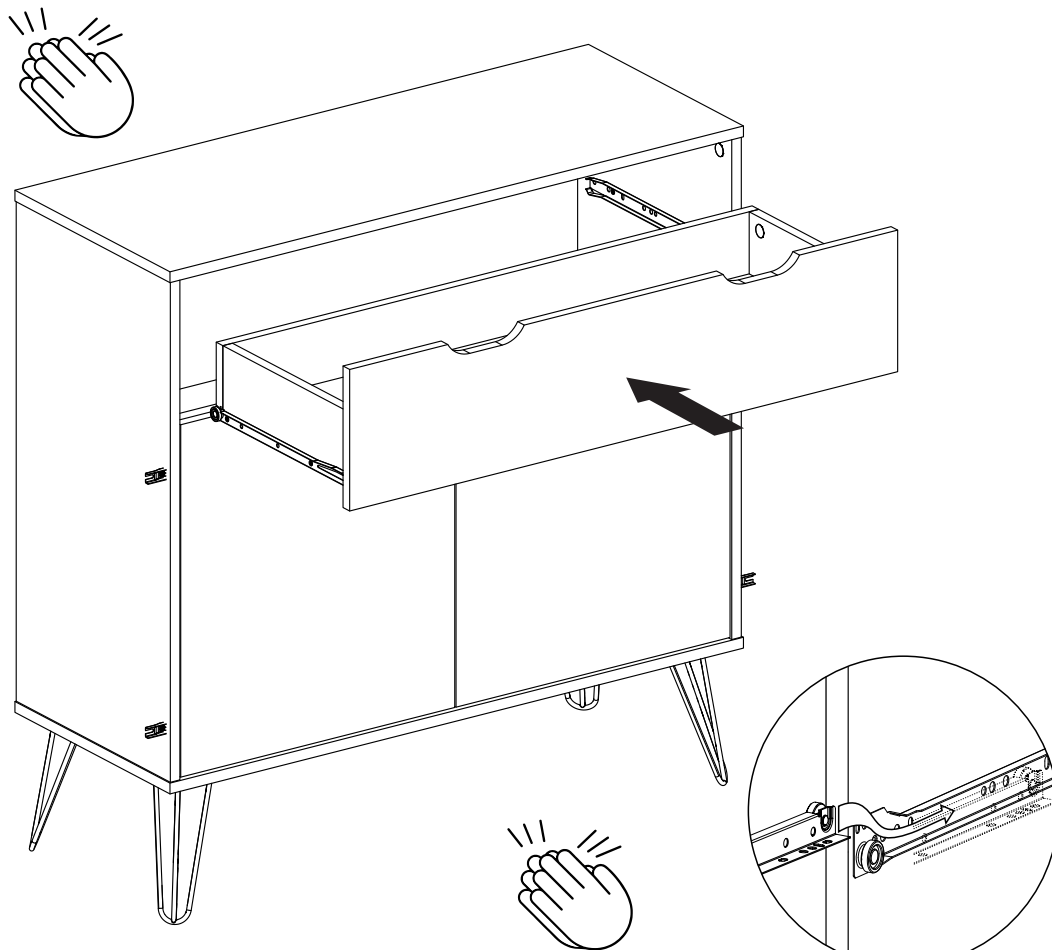

Detalhe 14
Detail/Detalle

Parabéns, você montou seu móvel! Agora é só decorar sua casa e aproveitar!

Queremos ver como ficou o móvel Artely do seu jeito... Marque a gente com a #meuartely. Ficaremos felizes em compartilhar!

Ah, e se tiver qualquer dúvida, sugestão ou comentário, entra em contato com a gente pelo nosso site www.artely.com.br.

¡Congratulaciones, montaste tu mueble! ¡Ahora solo decora tu casa y disfruta!

Queremos ver este producto en tu hogar, a tu manera... Utilice #meuartely, ¡ficaremos encantados de compartir tu foto!

Si tienes alguna duda, sugerencia o comentario, contáctenos a través de nuestro sitio web www.artely.com.br.

Congratulations, you've assembled your new furniture! Decorate your home and enjoy!

We want to see how this product is in your home... Use #meuartely, we will be happy to share your picture!

If you have any doubt, suggestion or comment, get in touch with us through our website www.artely.com.br.