

Conservación y Limpieza Conservation and Cleaning

Não expor o produto ao sol, altas temperaturas e umidade. Não arrastar objetos sobre a superfície do móvel (ex.: TV, DVD, aparelho de som, objetos decorativos...) e manter em local seco e arejado. Para a limpeza, utilizar um pano seco e macio. Não é necessário o uso de materiais abrasivos ou álcool.

No exponga el producto a la luz solar, las altas temperaturas y la humedad. No arrastre los objetos a través de la superficie de la unidad (por ejemplo, TV, DVD, equipo de música, objetos de decoración ...) Mantener en un lugar fresco y seco.

Para a limpeza, utilizar un paño seco y suave. El uso de materiales abrasivos o del alcohol no es necesario.

Do not expose the product to sunlight, high temperatures and humidity. Do not drag objects across the surface of the unit (TV, DVD, stereo, decorative objects ...) keep it in a cool dry place. For cleaning, use a dry and soft cloth. Do not use abrasive materials or alcohol.

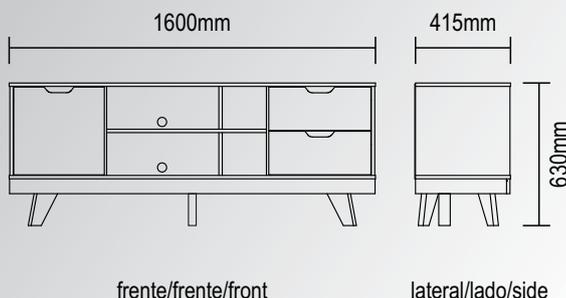
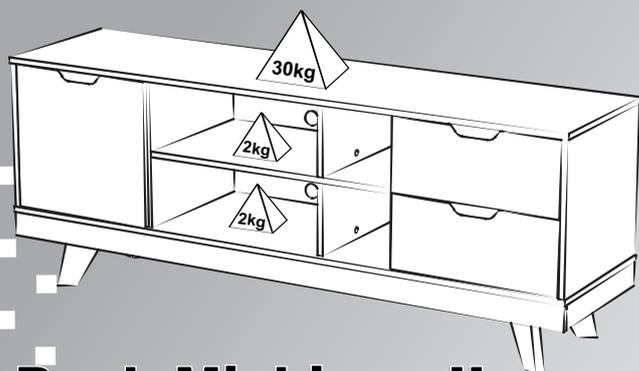

Rack Michigan II

Rack Michigan II / Michigan II Tv Stand

Versão 1.1 / Versión 1.1 / Version 1.1

Assista ao vídeo com dicas de montagem em nosso site: www.artely.com.br

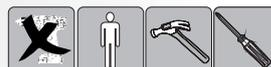

Lista de Materiais

Lista de Materiales/ Hardware List

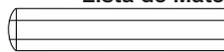
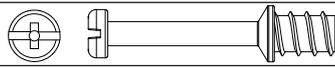
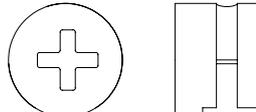
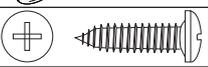
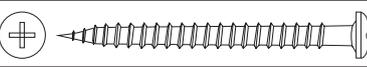
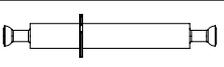
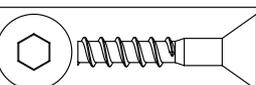
| | | | |
|----------|---|--|-----------|
| A |  | Cavilha / Tarugo / Dowel Ø6x30mm | 48 |
| B |  | Minifix Minifix / Minifix Ø7x30mm | 16 |
| C |  | Tambor Tambor / Minifix Cam Ø15x12mm | 18 |
| D |  | Tapa furo adesivo / Adhesivo / Hole Cover Ø18mm | 12 |
| E |  | Parafuso / Tornillo / Screw Ø4,0x14mm CP | 24 |
| F |  | Parafuso Tornillo / Screw Ø3,5x40mm CP | 12 |
| G |  | Haste Dupla Minifix Minifix Doble Varilla/Double Rod Minifix Ø7x60mm | 01 |
| H |  | Prego / Clavo / Nail 8x8 | 28 |
| I |  | Parafuso / Tornillo / Screw Ø5,0x24mm | 12 |

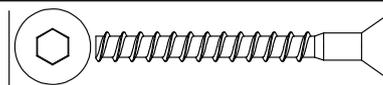
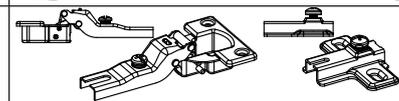
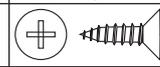
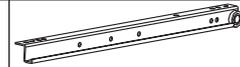
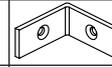
| | | | |
|----------|--|--|-----------|
| J |  | Parafuso Tornillo / Screw Ø5x40mm cab 10 | 10 |
| K |  | Kit Dobradiça Alta Kit de bisagras altas High Hinge Kit | 02 |
| L |  | Parafuso / Tornillo / Screw Ø3,5x10mm CC - Metal | 16 |
| M |  | Corrediça / Guia / Slider 300mm | 04 |
| N |  | Corrediça / Guia / Slider 300mm | 04 |
| O |  | Cantoneira / Cantonera / Corner Brace 25x25x13mm | 04 |
| P |  | Suporte Angular / Soporte Angular / Plastic Corner Brace 24x16x13mm | 04 |
| Q |  | Sapata Fixa / Pata Fija / Fixed Foot Ø5x10mm | 05 |
| R |  | Chave Zeta / Clave Zeta / Allen Key | 01 |

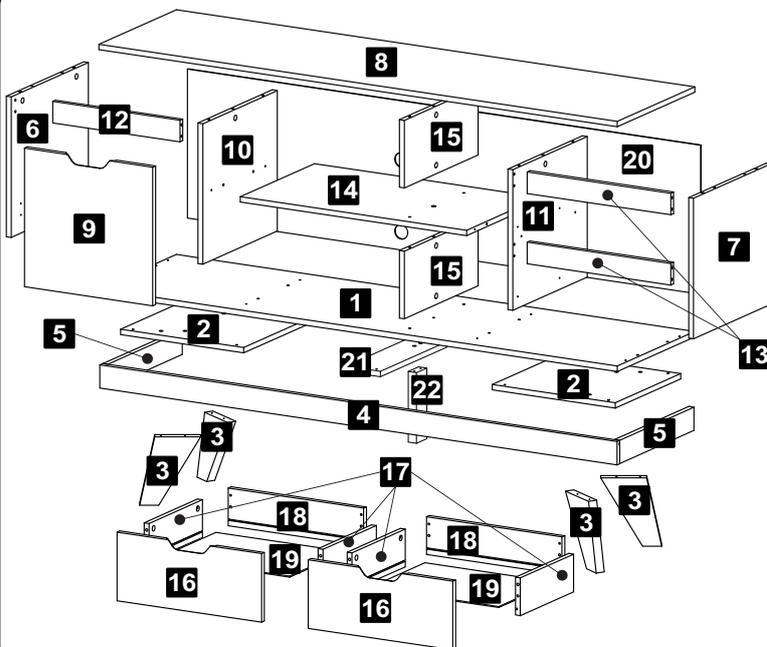

| Descrição | Descripción | Description |
|------------------------------------|-----------------------|----------------------|
| 1-Base (1600x415x15mm) | 1-Base | 1-Base |
| 2-Suporte lateral (350x380x15mm) | 2-Titular lateral | 2-Side support |
| 3-Pé (220x120x25mm) | 3-Pies | 3-Feet |
| 4-Encabeç frontal (1596x65x15mm) | 4-Encabezado frontal | 4-Front header |
| 5-Encabeç lateral (398x65x15mm) | 5-Encabezado lateral | 5-Side header |
| 6-Lateral esq (391x413x15mm) | 6-Lateral izquierda | 6-Left side |
| 7-Lateral dir (391x413x15mm) | 7-Lateral derecha | 7-Right side |
| 8-Tampo (1600x415x15mm) | 8-Tapa | 8-Top |
| 9-Porta (386x396x15mm) | 9-Puerta | 9-Door |
| 10-Divisão esquerda (391x398x15mm) | 10-Division izquierda | 10-Left partition |
| 11-Divisão direita (391x398x15mm) | 11-Division derecha | 11-Right partition |
| 12-Travessa porta (393x60x15mm) | 12-Travesaño puerta | 12-Door crosspiece |
| 13-Travessa (443x60x15mm) | 13-Travesaño | 13-Crosspiece |
| 14-Prateleira (698x396x15mm) | 14-Anaqueel | 14-Shelf |
| 15-Divisão menor (188x394x15mm) | 15-Division menor | 15-Smaller partition |
| 16-Frente gaveta (446x191x15mm) | 16-Frente cajón | 16-Drawer front |
| 17-Latera gaveta (285x105x15mm) | 17-Lateral cajón | 17-Drawer side |
| 18-Traseira gaveta (418x105x15mm) | 18-Trasera cajón | 18-Drawer back |
| 19-Fundo gaveta (398x295x3mm) | 19-Fondo cajón | 19-Drawer bottom |
| 20-Traseira (1584x415x3mm) | 20-Trasera | 20-Back |
| 21-Suporte central (350x105x15mm) | 21-Titular central | 21-Central support |
| 22-Pé central (194x55x25mm) | 22-Pies central | 22-Central Foot |

1 Passo
Paso
Step

Peça 01 →

- O número na borda da peça corresponde ao manual.
- Para retirada do número usar Lustra-Móveis ou Alcool em Gel.
- El número en el borde de la pieza coincide con el manual.
- Use alcohol en gel o lustrador para muebles para eliminar los números.
- The number on the edge of the piece matches the manual.
- Use Alcohol Gel or Furniture Polish to remove the numbers.

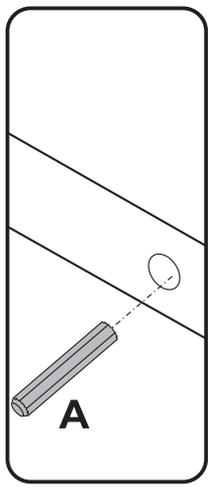
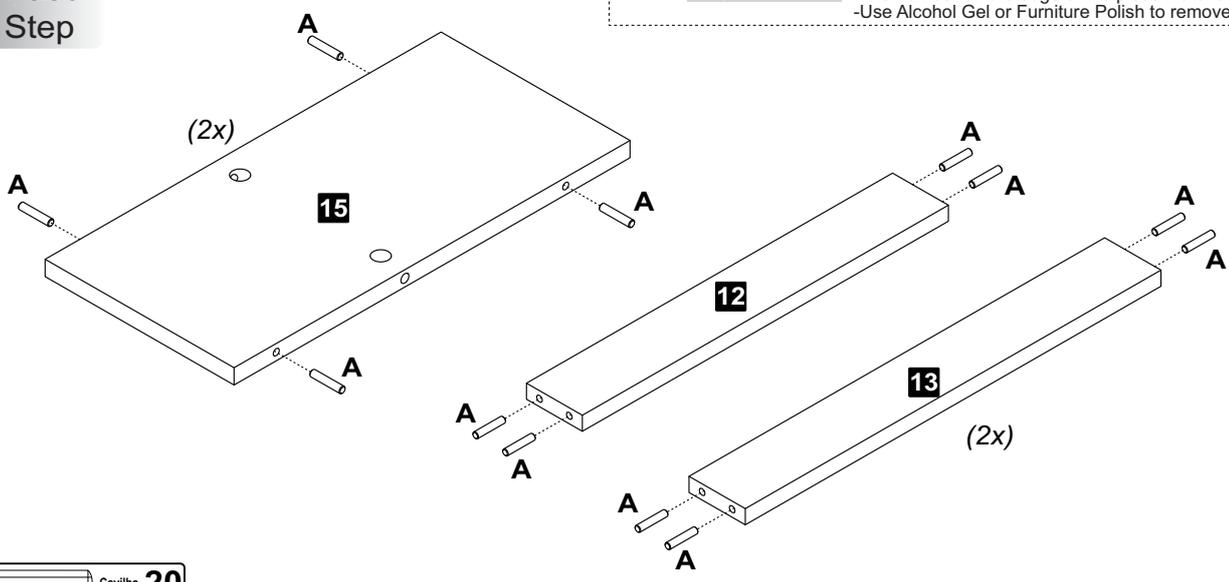

A Cavilha 20

2 Passo
Paso
Step

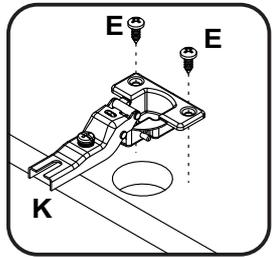
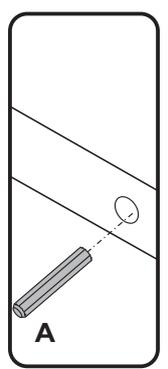
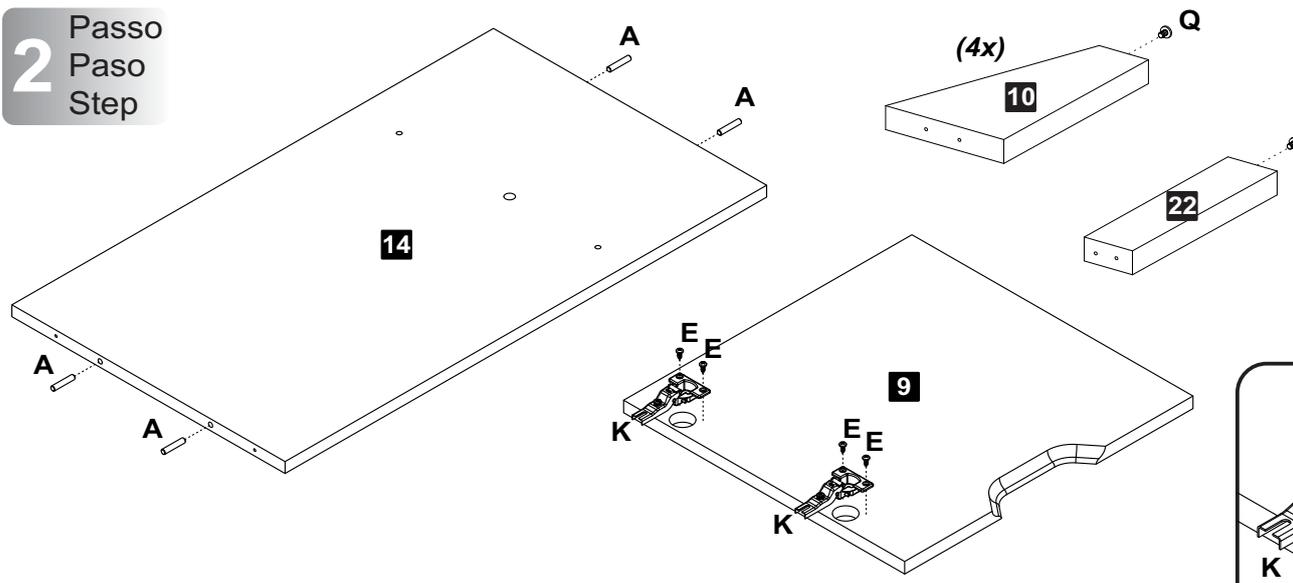

A Cavilha 04 **E** Parafuso Ø4,0x14mm CP 04 **K** Kit Dobradiça Ata 02 **Q** Sapata Fixa 05

3 Passo
Paso
Step

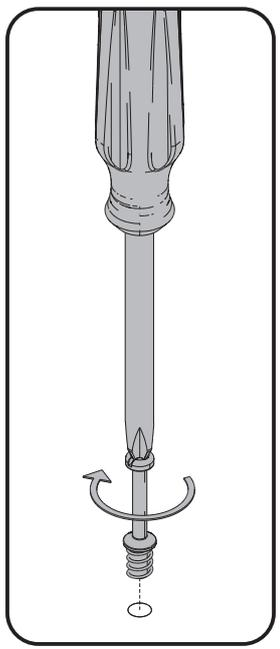
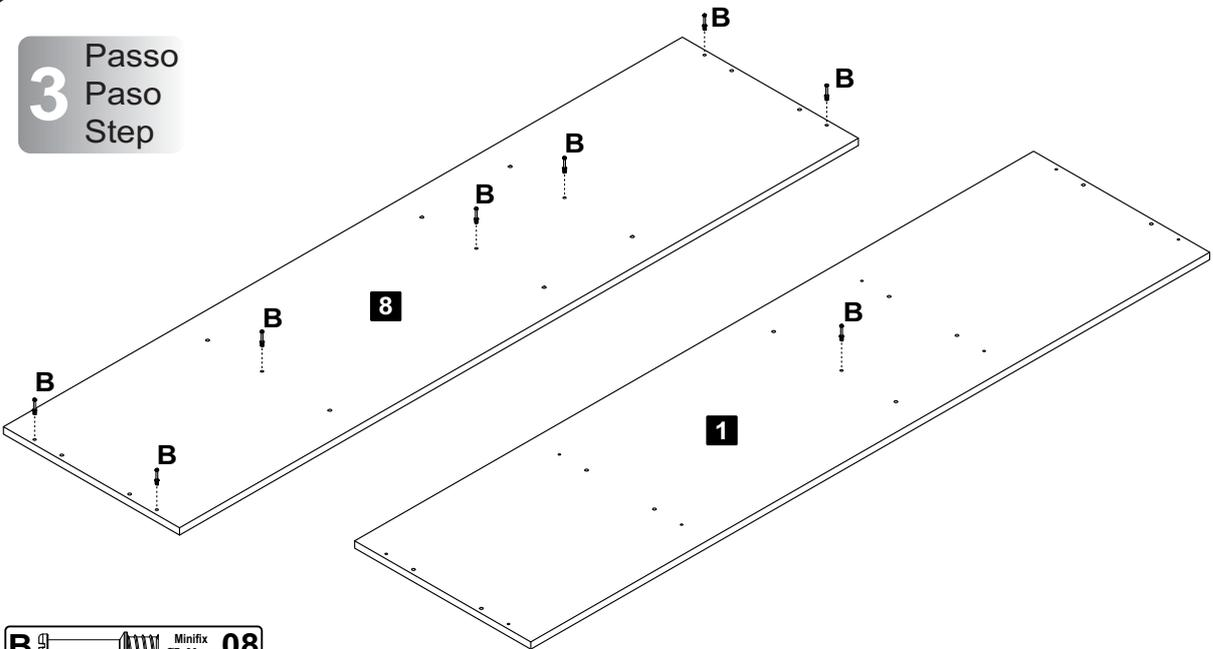

B Minifix Ø7x30mm 08

4 Passo
Paso
Step

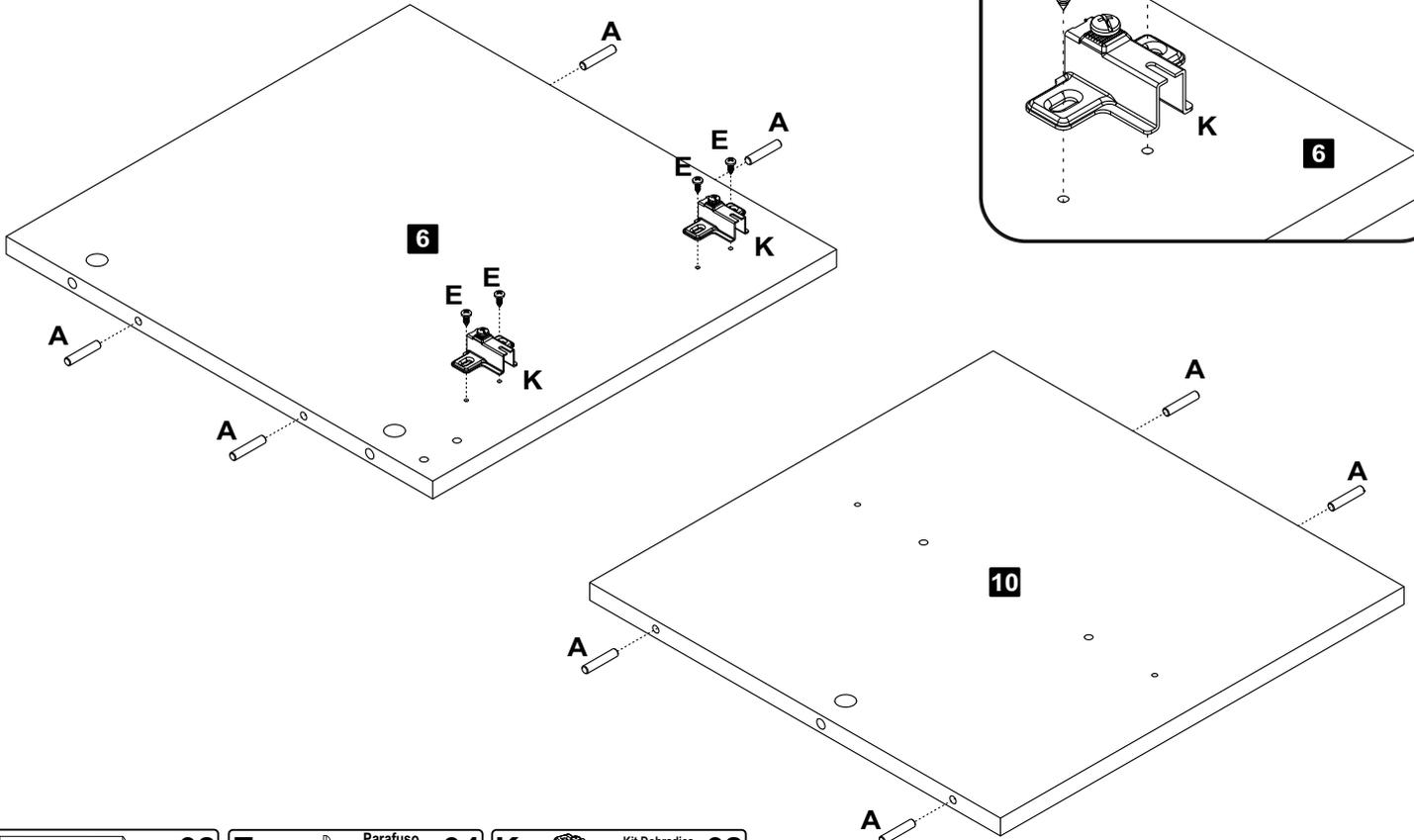

A Caviha 08 **E** Parafuso Ø4,0x14mm CP 04 **K** Kit Dobradiça Alta 02

5 Passo
Paso
Step

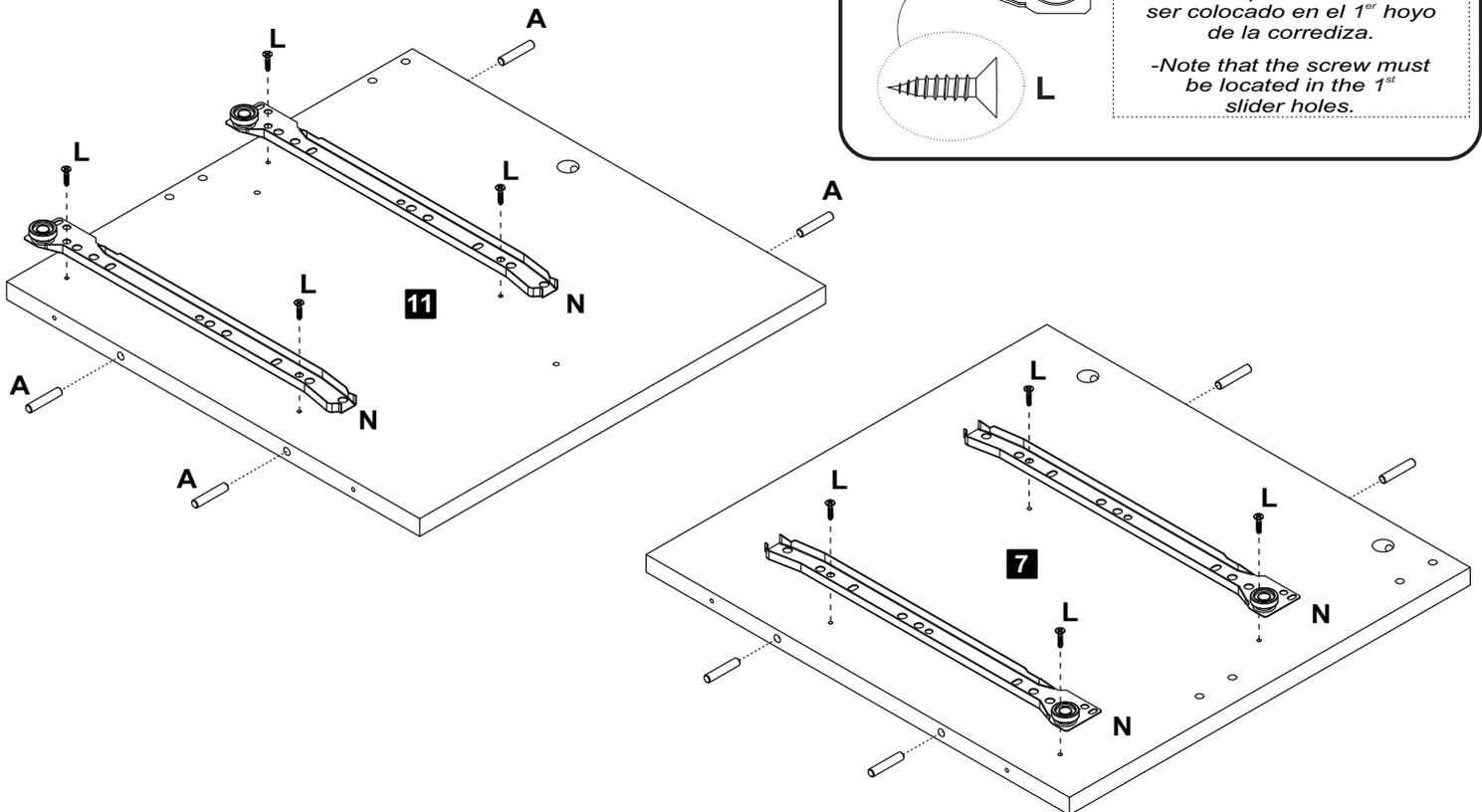

A Caviha 08 **L** Parafuso Ø3,5x10mm CC 08 **N** Corredeira 300mm 04

6 Passo
Paso
Step

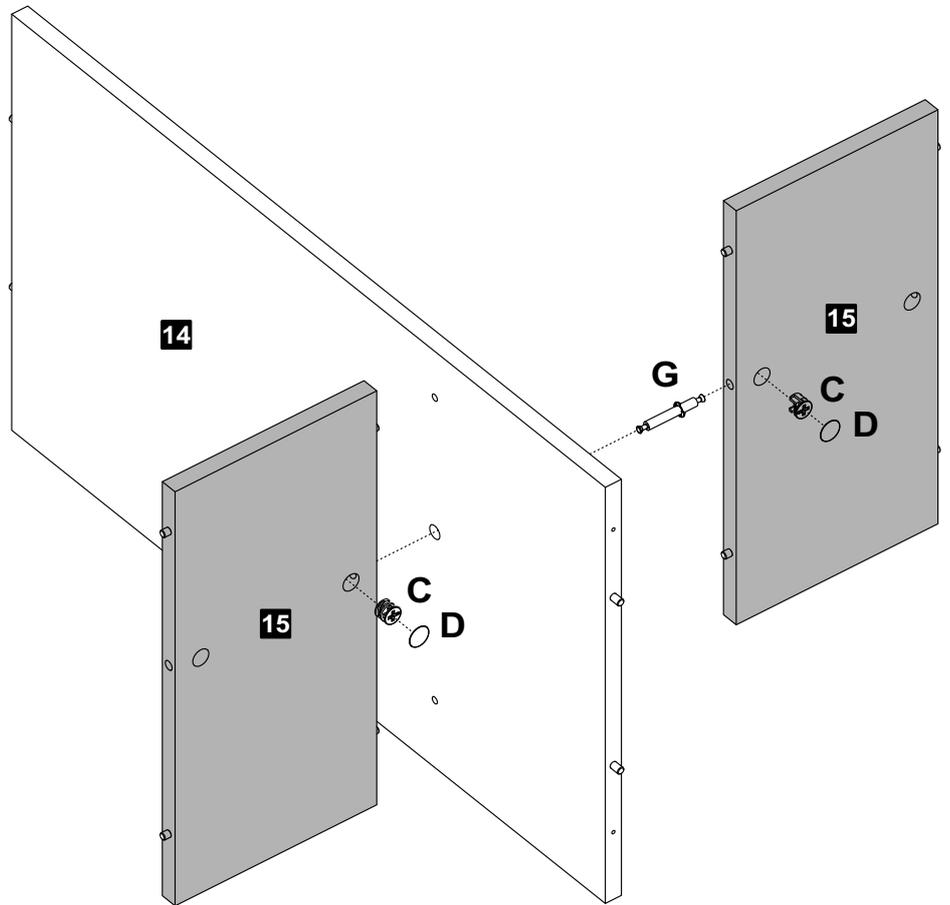
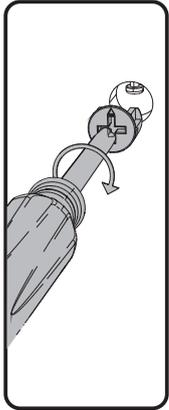
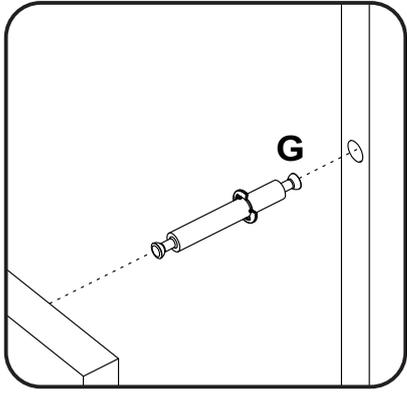

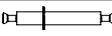
- C**  Tambor **03**
- D**  Tapa Furo Adesivo **03**
- G**  Haste Dupla Minifix **01**

7 Passo
Paso
Step

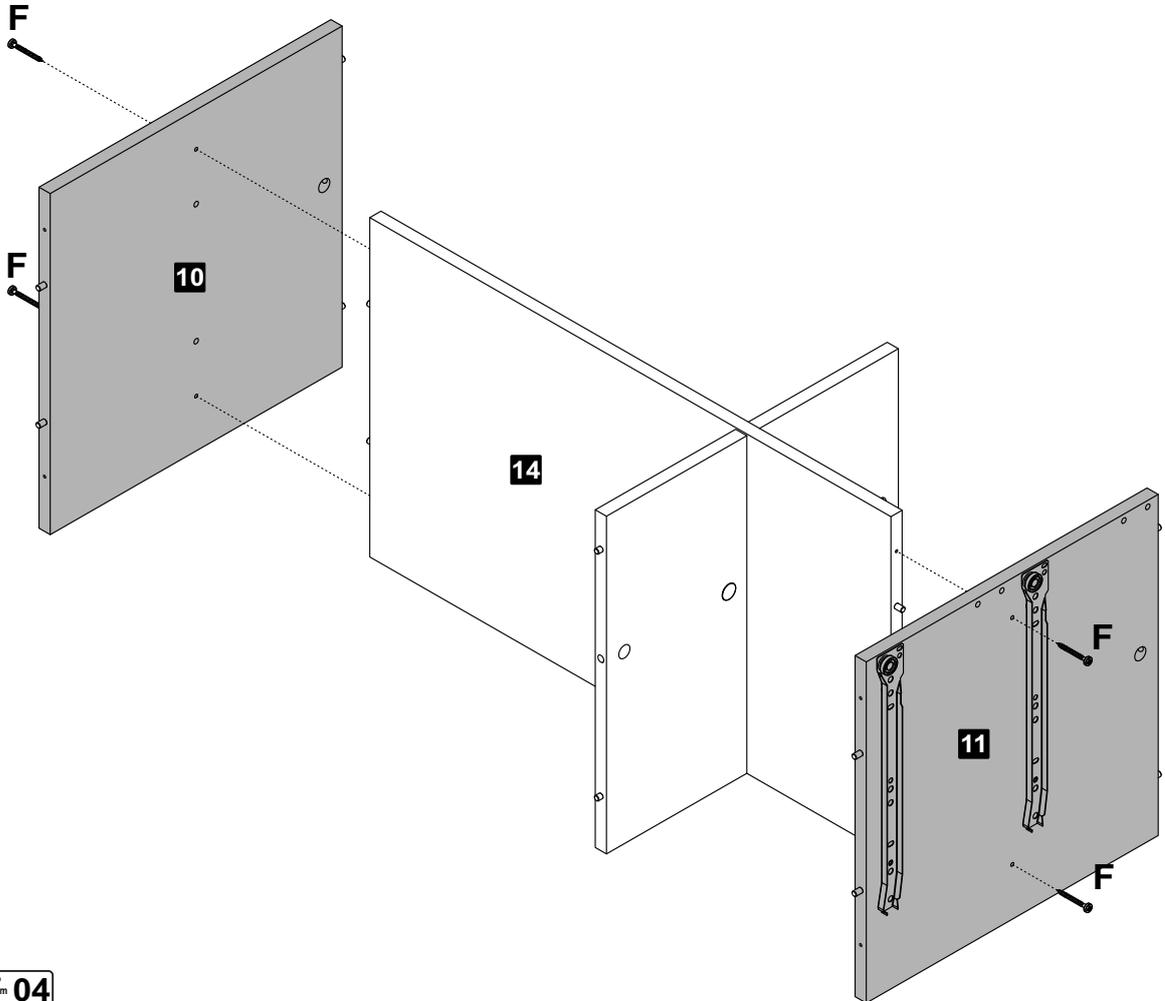

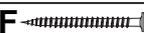
- F**  Parafuso Ø3,5x40mm CP **04**

8
Passo
Paso
Step

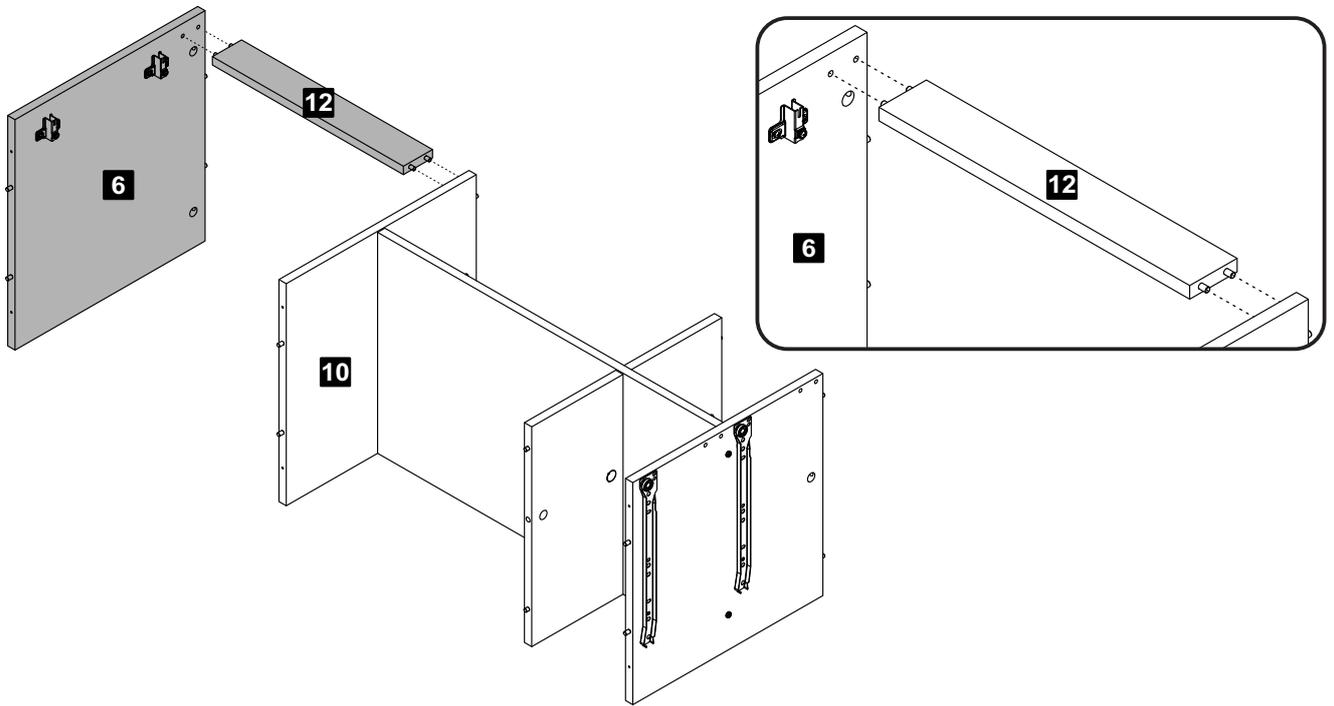

9
Passo
Paso
Step

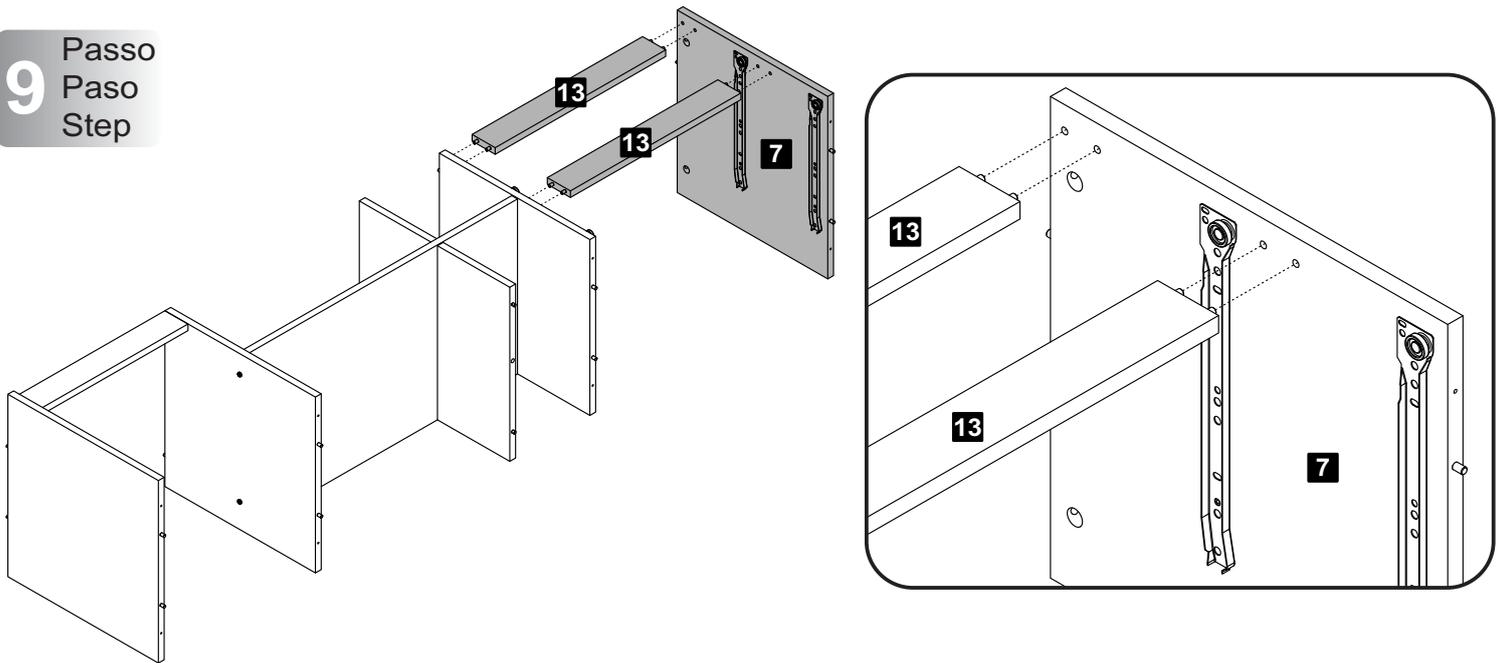

10
Passo
Paso
Step

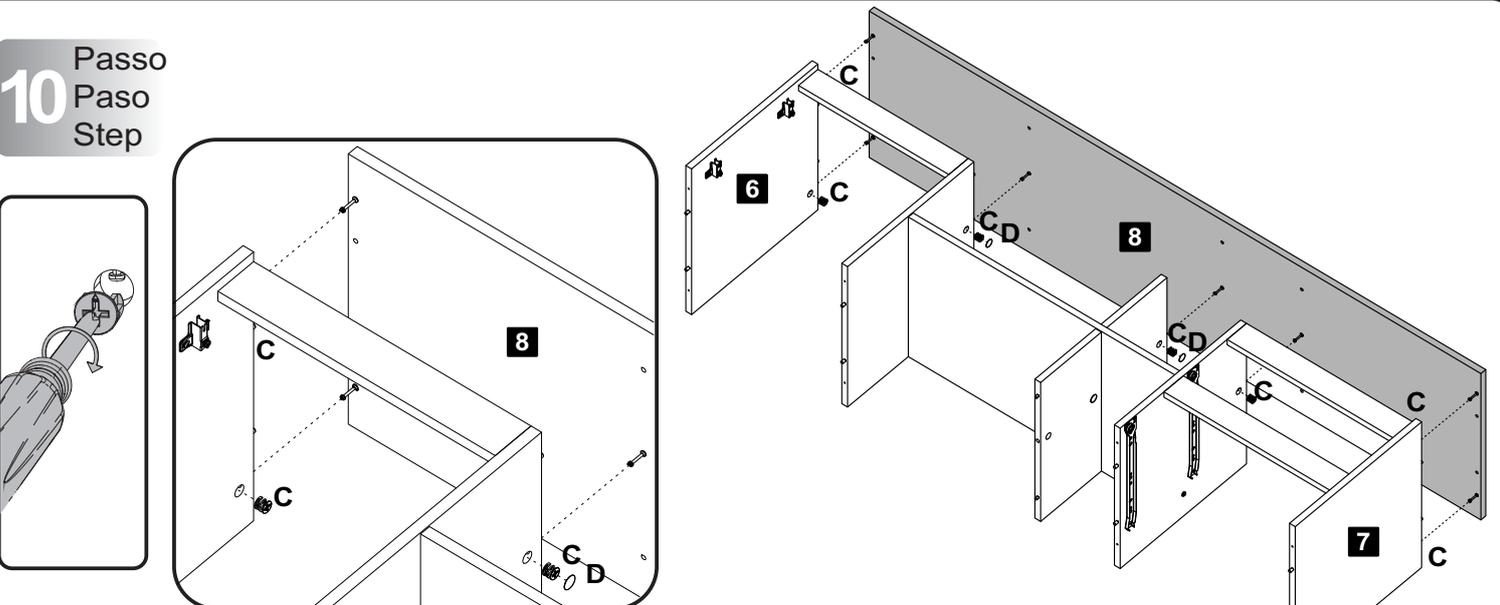

C



Tambor 07

D



Tapa Furo Adesivo 02

11 Passo
Paso
Step

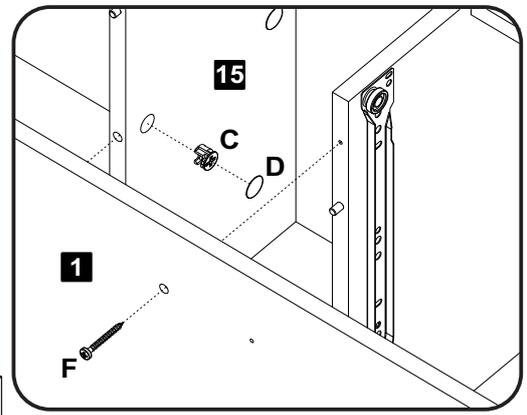
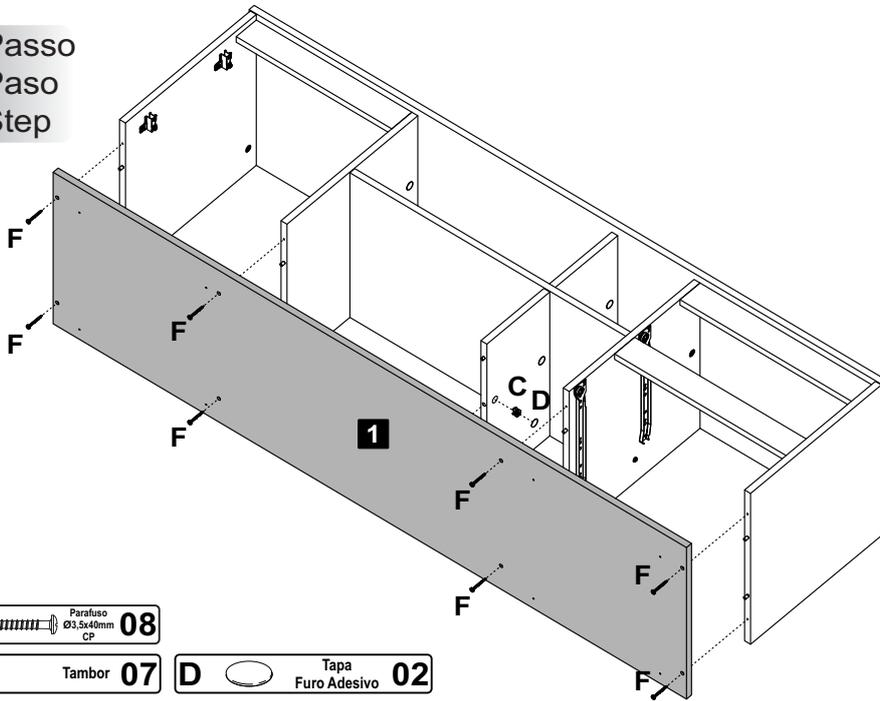

F Parafuso Ø3,5x40mm CP **08**

C Tambor **07**

D Tapa Furo Adesivo **02**

12 Passo
Paso
Step

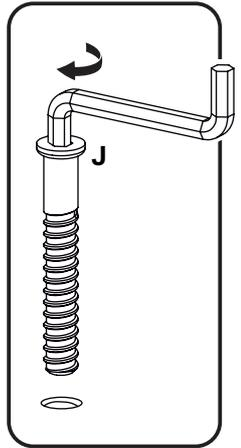
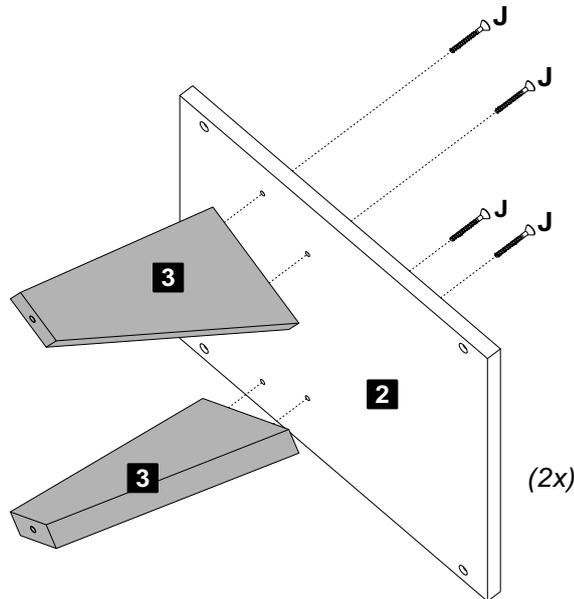
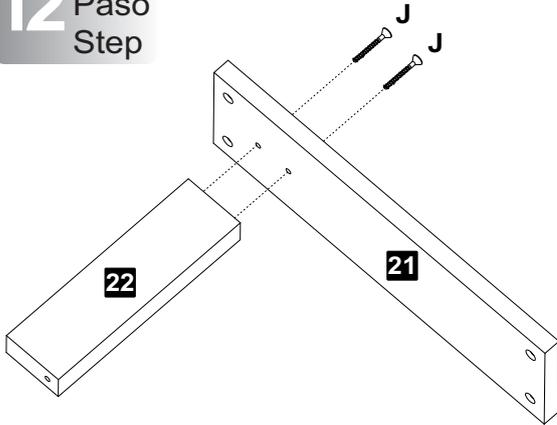

(2x)

J Parafuso Ø5x40mm **10**

13 Passo
Paso
Step

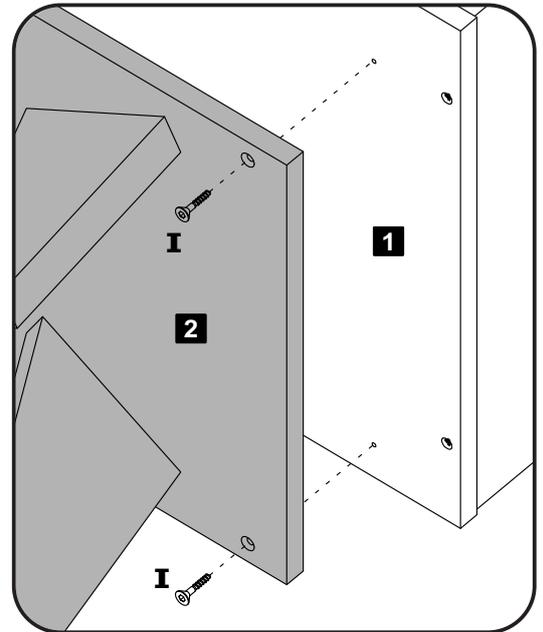
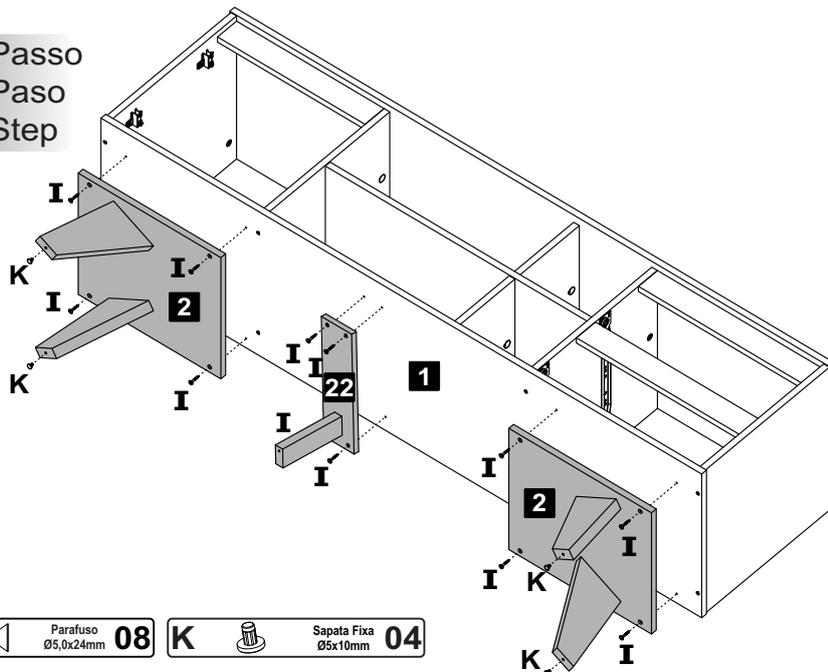

I Parafuso Ø5,0x24mm **08**

K Sapata Fixa Ø5x10mm **04**

14 Passo
Paso
Step

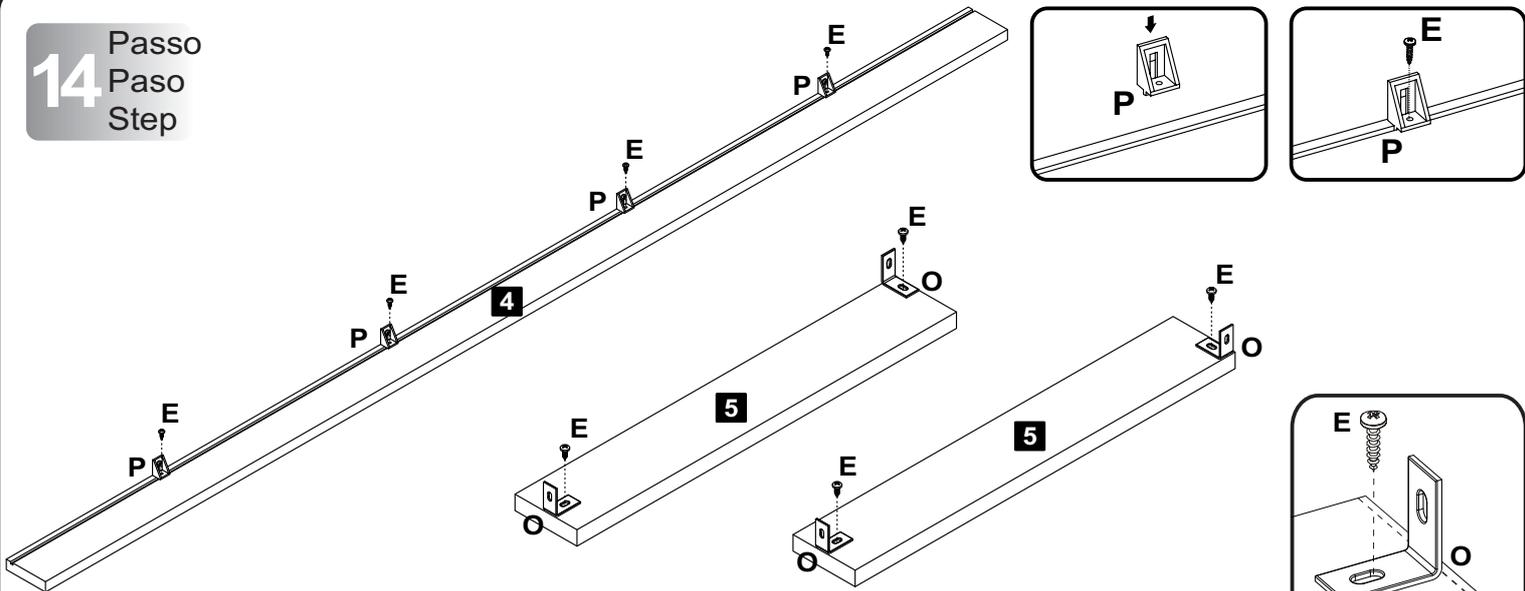

A Cavilha **04**

E Parafuso $\varnothing 4,0 \times 14 \text{mm}$ CP **06**

O Cantoneira $1'' \times 1''$ **04**

P Suporte Angular **04**

-Aproximadamente 1mm da borda
-Aproximadamente 1 mm desde el borde
-Around 1mm of the edge.

15 Passo
Paso
Step

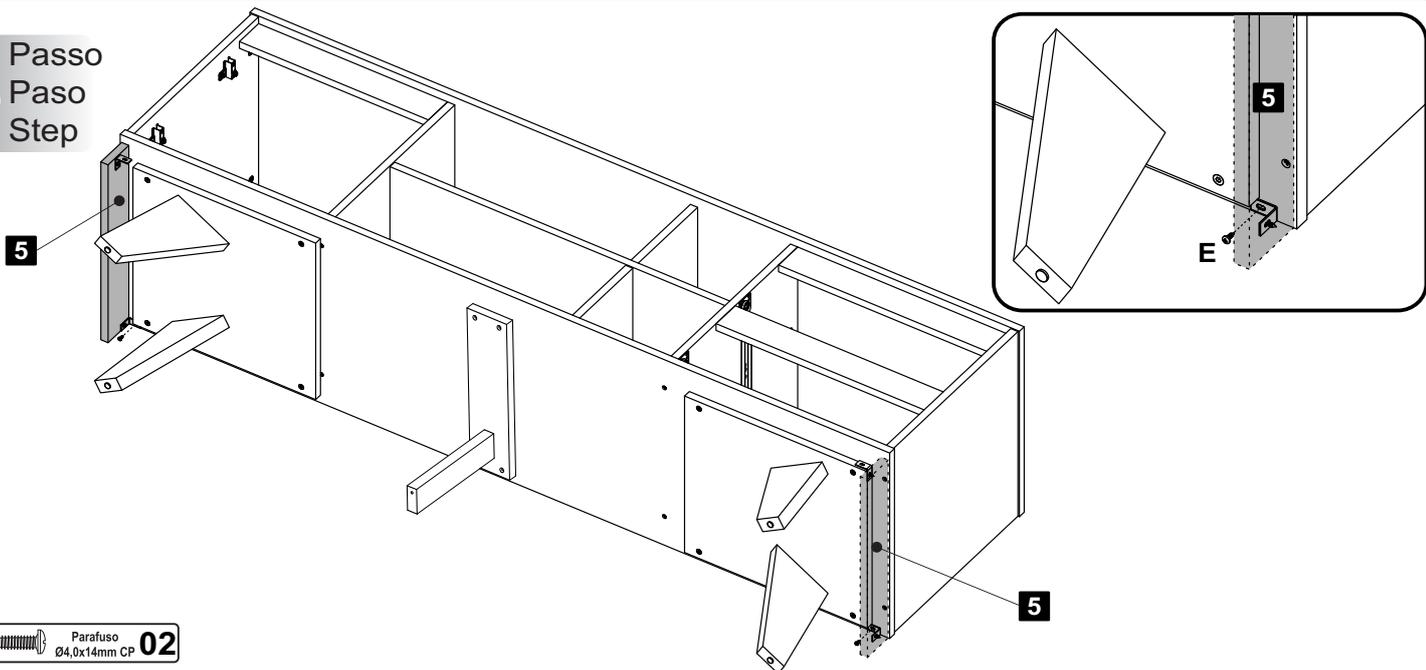

E Parafuso $\varnothing 4,0 \times 14 \text{mm}$ CP **02**

16 Passo
Paso
Step

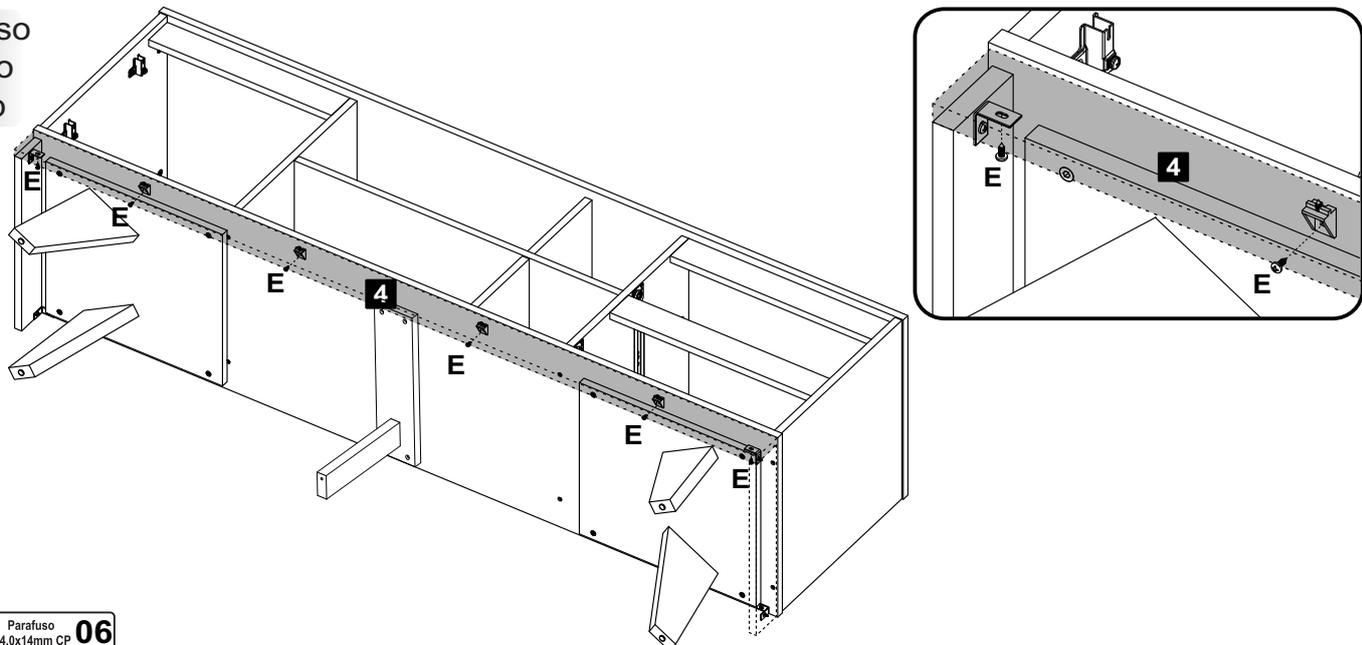

E Parafuso $\varnothing 4,0 \times 14 \text{mm}$ CP **06**

17 Passo
Paso
Step

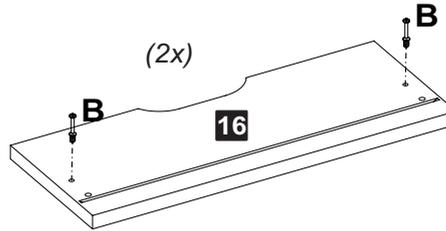
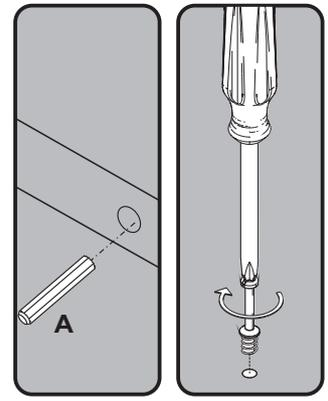
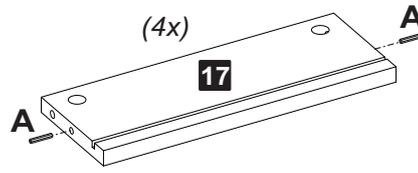
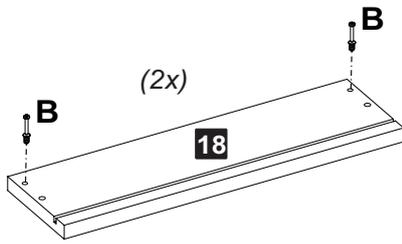

18 Passo
Paso
Step

1 Passo
Paso
Step

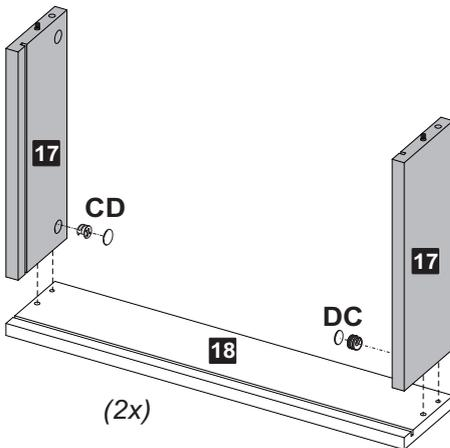

2 Passo
Paso
Step

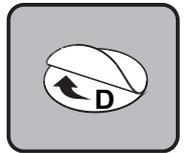
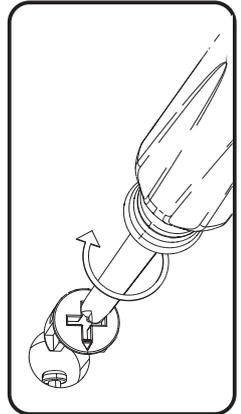
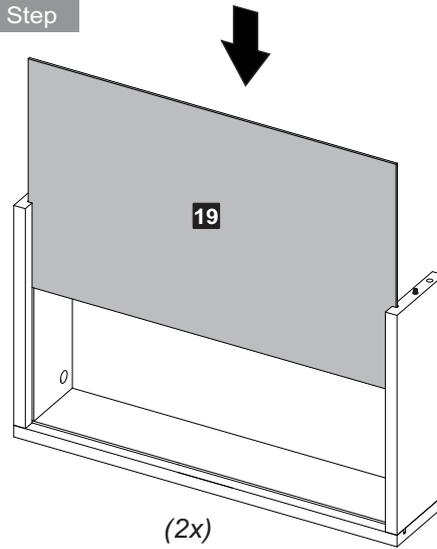

19 Passo
Paso
Step

3 Passo
Paso
Step

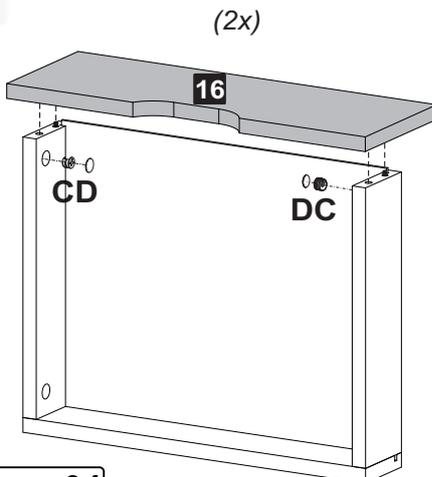

4 Passo
Paso
Step

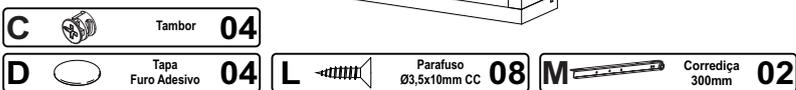
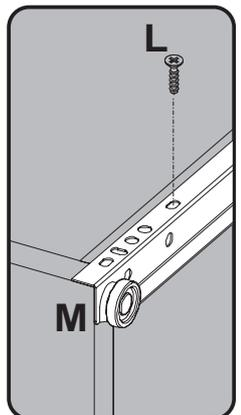
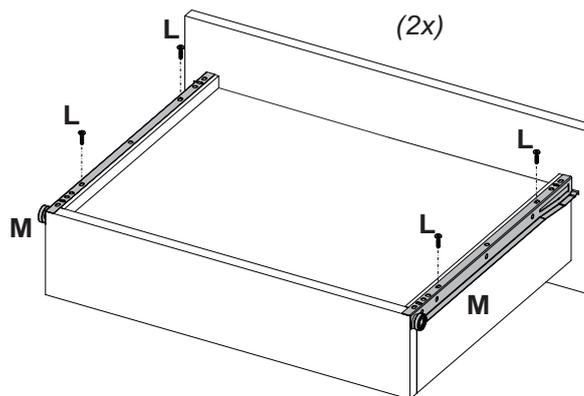

20 Passo
Paso
Step

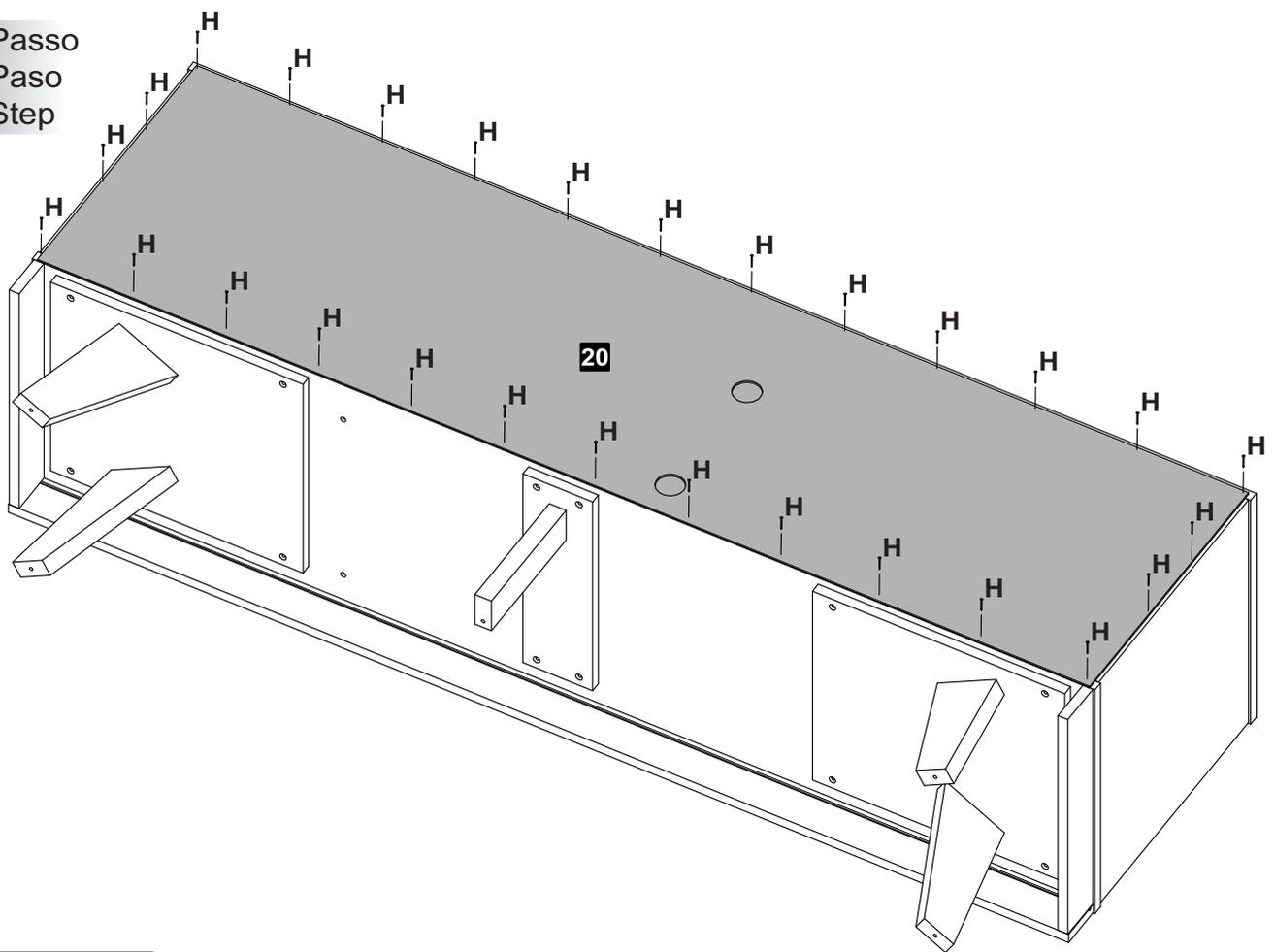

H ← Prego **28**

21 Passo
Paso
Step

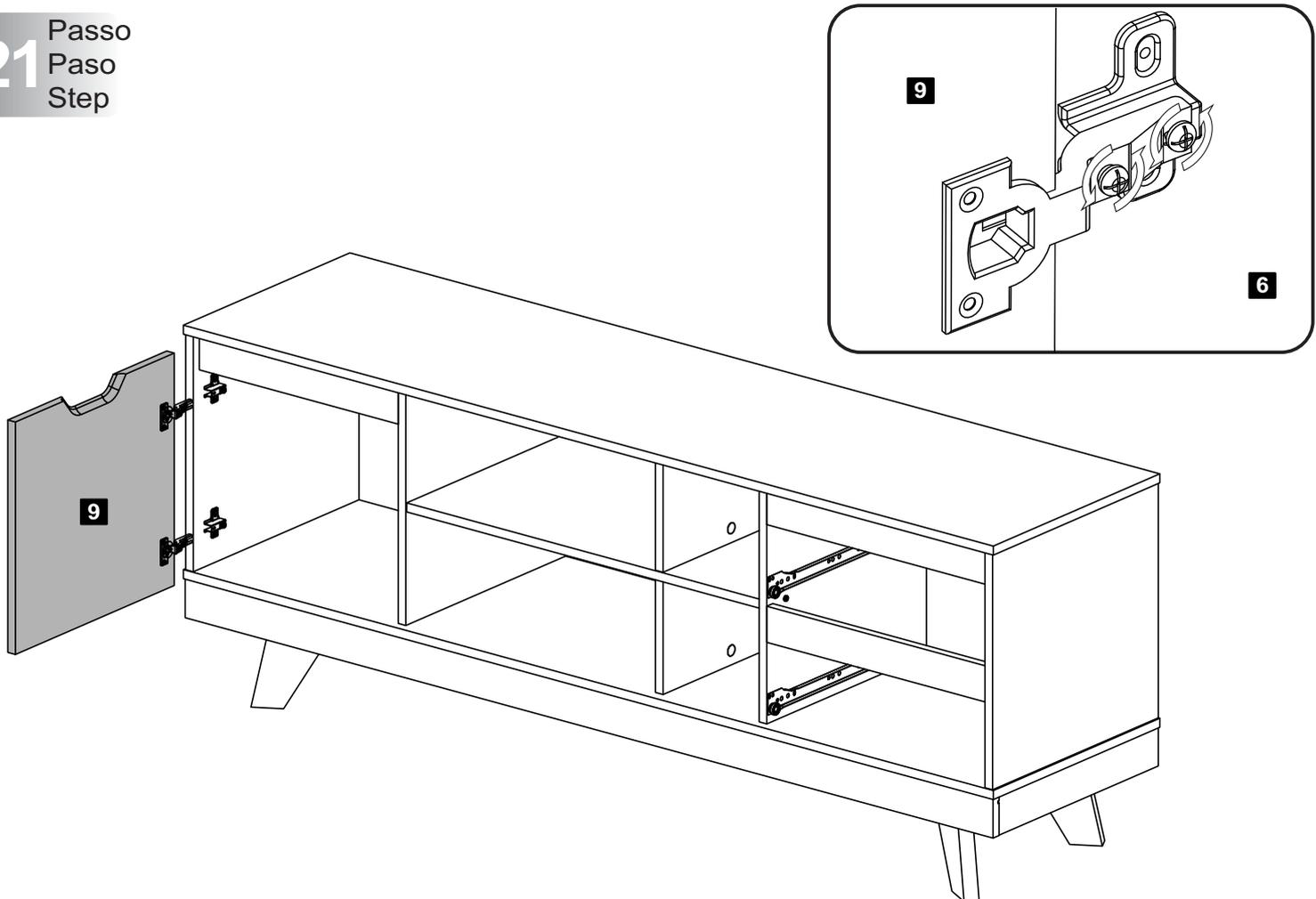

22 Passo
Paso
Step

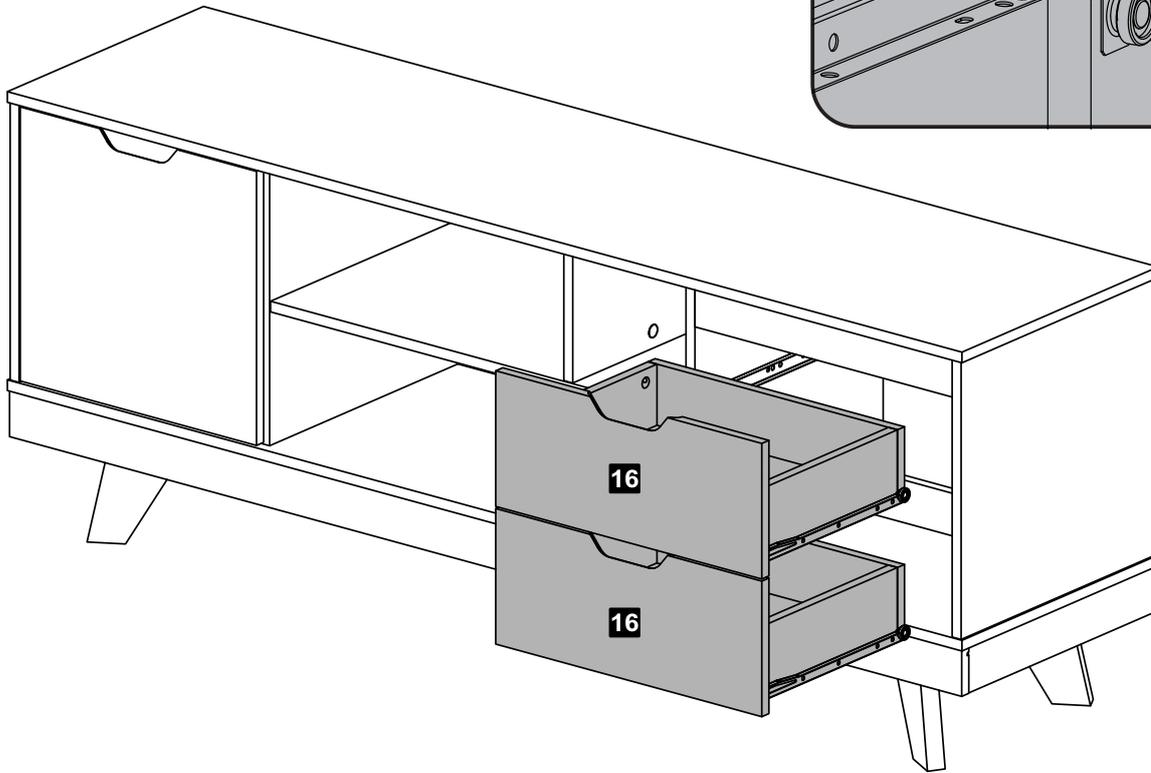
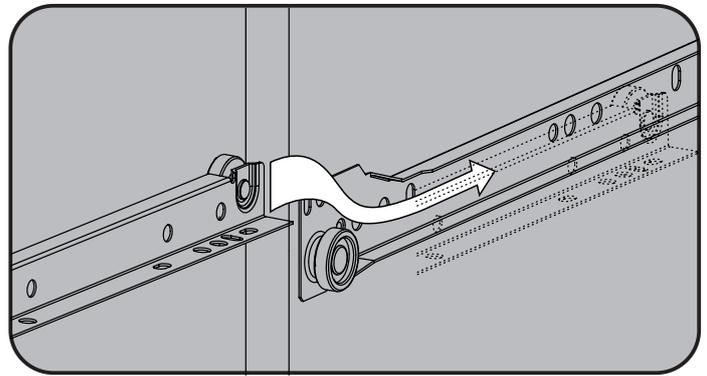

Parabéns, você montou seu móvel! Agora é só decorar sua casa e aproveitar!

Queremos ver como ficou o móvel Artely do seu jeito... Marque a gente com a #meuartely. Ficaremos felizes em compartilhar!

Ah, e se tiver qualquer dúvida, sugestão ou comentário, entra em contato com a gente pelo nosso site www.artely.com.br.

¡Congratulaciones, montaste tu mueble! ¡Ahora solo decora tu casa y disfruta!

Queremos ver este producto en tu hogar, a tu manera... Utilice #meuartely, ¡ficaremos encantados de compartir tu foto!

Si tienes alguna duda, sugerencia o comentario, contáctenos a través de nuestro sitio web www.artely.com.br.

Congratulations, you've assembled your new furniture! Decorate your home and enjoy!

We want to see how this product is in your home... Use #meuartely, we will be happy to share your picture!

If you have any doubt, suggestion or comment, get in touch with us through our website www.artely.com.br.

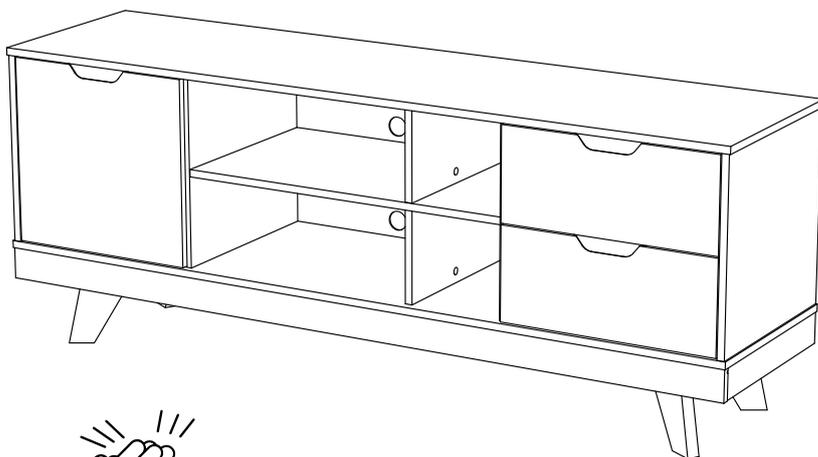

Garantia

Este certificado de Garantia é uma vantagem adicional oferecida ao consumidor, porém para que o mesmo tenha validade é imprescindível que seja apresentada a NOTA FISCAL de compra do produto.

Com este produto, a **Artely** tem como objetivo atender plenamente o proprietário-consumidor, proporcionando a garantia na forma aqui estabelecida, pelo período de três meses a partir da data da nota fiscal de compra. A **Artely** restringe a sua responsabilidade à substituição gratuita das peças defeituosas, em caso de defeitos ou avarias devidamente constatados como sendo de fabricação, durante a vigência desta garantia.

A **Artely** declara a garantia nula e sem efeito se o produto for alterado, adulterado, molhado ou consertado e ainda pela prática de montagem inadequada ou mau uso. Também será considerada nula em casos de força maior, como aqueles causados por agentes da Natureza (chuvas, incêndios, excesso de umidade, cupins...) e eventos externos como objetos arrastados sobre a superfície do móvel (ex.: TV, DVD, aparelho de som, objetos decorativos...).

Para exercer seus direitos de comprador é importante que antes de montar seu produto você leia com atenção as instruções de cada passo do manual de montagem que acompanha o móvel.

Caso o produto não esteja em conformidade, entre em contato com a loja onde efetuou a compra ou com o nosso Serviço de Atendimento ao Cliente através do e-mail assistencia@artely.com.br ou pelo fone 41 3381 5000 e faça sua reclamação, apontando os defeitos técnicos observados, que teremos o maior prazer em atendê-lo. Para agilizar o seu atendimento, tenha sempre em mãos o manual de montagem com os respectivos números das peças defeituosas, conforme descritas no manual.



ARTELY MÓVEIS LTDA
ALAMEDA ARPO, 2333
CEP / ZIP CODE: 83010-290
SÃO JOSÉ DOS PINHAIS
CURITIBA - PR - BRASIL
Fone / Fax: 41 3381-5000
Phone Number: 55 41 3381-5000
e-mail: artely@artely.com.br
www.artely.com.br