



Para facilitar a fixação do Suporte Universal, enviamos 2 modelos de parafusos que estão de acordo com os padrões mais usados pelos principais fabricantes de TVs LCD / LED / PLASMA / 3D do mercado. Caso nenhum dos 2 modelos se encaixe adequadamente ao seu televisor, adquira o parafuso compatível com sua TV em qualquer loja de ferragens. Para evitar danos à sua TV, não aperte demasiadamente os parafusos.



Atenção

Retirar a TV do painel sempre que:

- Mover o painel
- Manusear os cabos por trás do painel
- Passar novos cabos

- Se a tomada estiver atrás do painel, cuide para que os cabos não fiquem forçando o painel para a frente.

Passos para retirar a TV do painel:

1



Atenção

A TV não sai para os lados devido às travas de segurança do suporte.

VISTA LATERAL

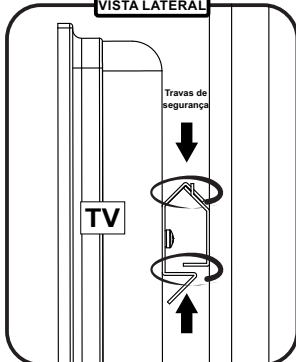

2

Inclinar um pouco a parte de baixo da TV até passar a trava de segurança inferior

VISTA LATERAL

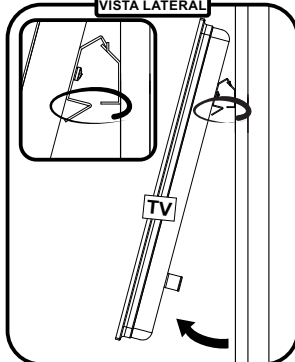

3

Elevar a TV retirando-a totalmente do suporte

VISTA LATERAL

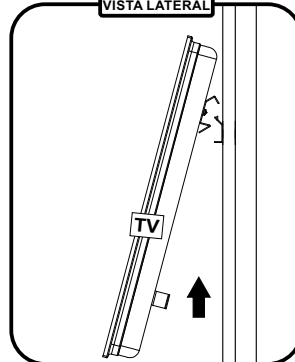

4

Desconectar todos os cabos da TV, retirando-a com segurança

VISTA LATERAL

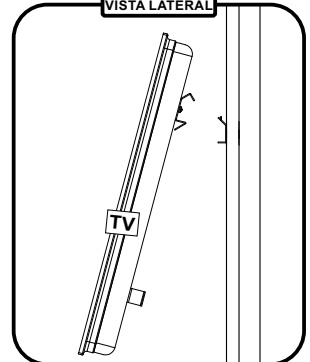

Este painel foi submetido a Testes de Resistência e suporta adequadamente o peso da TV. Não nos responsabilizamos por eventuais danos à TV causados por manuseio inadequado.



-Para una fácil fijación del soporte universal, enviamos 2 de los modelos de tornillos más utilizados en los televisores. Si ninguno encajar en su TV, busque otro en una ferretería. Para evitar daños en su televisor, no apriete demasiado los tornillos.
-To make it easier to attach the TV support, we send 2 screw models that match the most commonly used TVs. If neither model fits your TV properly, purchase the compatible screw from any hardware store. To prevent damage to your TV, do not over tighten the screws.



ATENCIÓN! ATTENTION!

Retire la TV del panel siempre que:

Take out the TV from the panel in the following situations:

- Mover el panel;
- You are moving the wall panel;
- Pasar nuevos cables.
- You are passing new cables.
- Manejar los cables detrás del panel;
- You are handling the cables;

- Si el tomacorriente está detrás del panel, tenga cuidado de que los cables no fuercen el panel adelante.

- If the power plug is behind the panel, be sure that the cables are not forcing the panel forward.

Pasos para retirar la televisión del panel: Steps to remove the TV from the wall panel:

1

-La TV no sale para los lados, debido a las travas de seguridad del soporte;

-There are safety locks in the support that keep the TV in its place. You can not take out the TV moving it to the sides.

VISTA LATERAL
SIDE VIEW

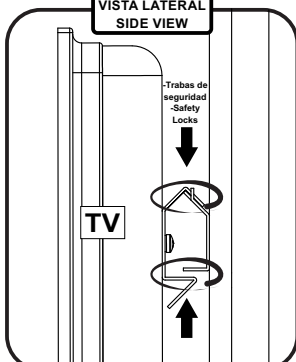

2

-Incline la parte inferior del televisor ligeramente hasta que pase la trava de seguridad inferior;

-Incline the bottom of the TV so that it passes the lower safety lock.

VISTA LATERAL
SIDE VIEW

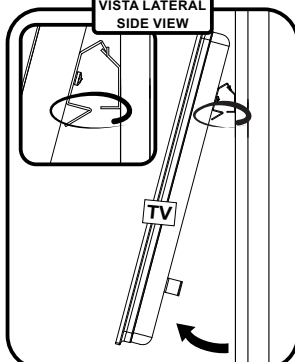

3

-Levante el televisor quitándolo completamente del soporte;

-Lift the TV, removing it completely from the support.

VISTA LATERAL
SIDE VIEW

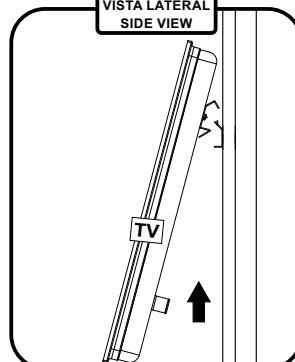

4

-Desconecte todos los cables de la TV, quitándola con seguridad.

-Disconnect all the TV cables and remove the TV safely.

VISTA LATERAL
SIDE VIEW

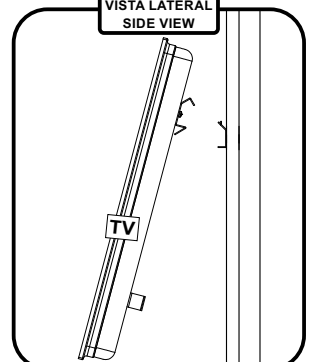

-Ese panel fue sometido a Pruebas de Resistencia y soporta adecuadamente el peso del televisor. No somos responsables de ningún daño al televisor causado por manejo inadecuado.

-This panel has undergone resistance tests and adequately supports the weight of the TV. We are not responsible for TV damage caused by inappropriate handling.

Não expor o produto ao sol, altas temperaturas e umidade. Não arrastar objetos sobre a superfície do móvel (ex.: TV, DVD, aparelho de som, objetos decorativos...) e manter em local seco e arejado. Para a limpeza, utilizar um pano seco e macio. Não é necessário o uso de materiais abrasivos ou álcool.

No exponga el producto a la luz solar, las altas temperaturas y la humedad. No arrastre los objetos a través de la superficie de la unidad (por ejemplo, TV, DVD, equipo de música, objetos de decoración ...) Mantener en un lugar fresco y seco.

Para a limpeza, utilizar um pano seco e suave. El uso de materiales abrasivos o del alcohol no es necesario.

Do not expose the product to sunlight, high temperatures and humidity. Do not drag objects across the surface of the unit (TV, DVD, stereo, decorative objects ...) keep it in a cool dry place. For cleaning, use a dry and soft cloth. Do not use abrasive materials or alcohol.

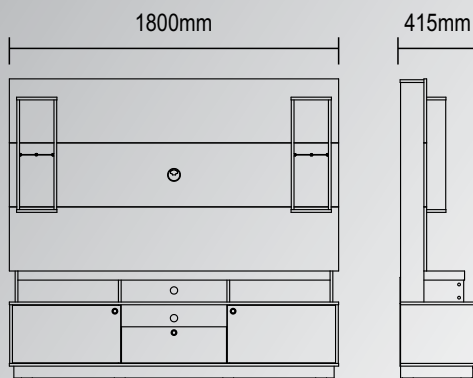
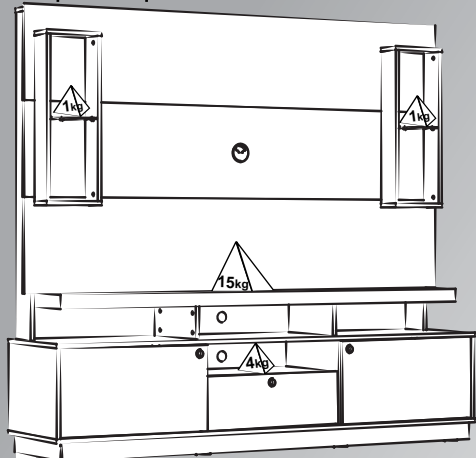

frente/frente/front

lateral/lado/side



Home Sevilha

Home Sevilha / Sevilha Home



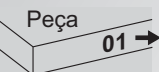



Versão 1.0 / Versión 1.0 / Version 1.0



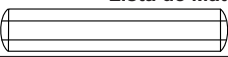

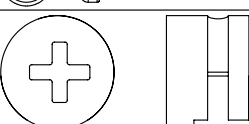

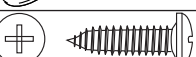
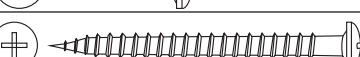
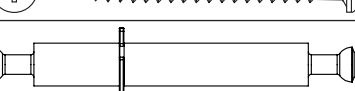
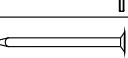

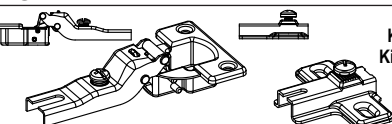
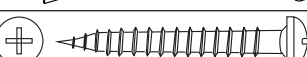

- O número na borda da peça corresponde ao manual.
- Para retirada do número usar Lustra-Móveis ou Alcool em Gel.
- El número en el borde de la pieza coincide con el manual.
- Use alcohol en gel o lustrador para muebles para eliminar los números.
- The number on the edge of the piece matches the manual.
- Use Alcohol Gel or Furniture Polish to remove the numbers.

Lista de Materiais

Lista de Materiales/ Hardware List

A		Cavilha / Tarugo / Dowel Ø6x30mm	64
B		Minifix Minifix / Minifix Ø7x30mm	46
C		Tambor Tambor / Minifix Cam Ø15x12mm	54
D		Tapa furo adesivo / Adhesivo / Hole Cover Ø18mm	24
E		Parafuso / Tornillo / Screw Ø4,0x14mm CP	24
F		Parafuso Tornillo / Screw Ø3,5x40mm CP	22
G		Haste Dupla Minifix Minifix Doble Varilla Double Rod Minifix Ø7x60mm	04
H		Prego / Clavo / Nail 8x8	56
I		Cantoneira / Cantonera / Corner Brace 25x25x13mm	04

J		Puxador / Tirador / Handle	03	
K		Kit Dobradiça Alta Kit de bisagras altas High Hinge Kit	01	
L		Parafuso / Tornillo / Screw Ø4,0x30mm CP	12	
M		Suporte Angular / Soporte Angular / Plastic Corner Brace 24x16x13mm	04	
N		Passa Fio / Pasacables / Cable Hole Cover Ø60mm	01	
O		Suporte Dot para Vidro Suporte de Vidrio / Glass Holder	06	
P		Sapata Square / Pata Square / Square Foot	08	
Q1		Guia / Guia / Guide	Kit porta de correr Kit Puerta Deslizante Sliding Door Kit	02
Q2		Roldana / Polea / Pulley		
Q3		Parafuso / Tornillo / Screw Ø3,5x12mm CF		

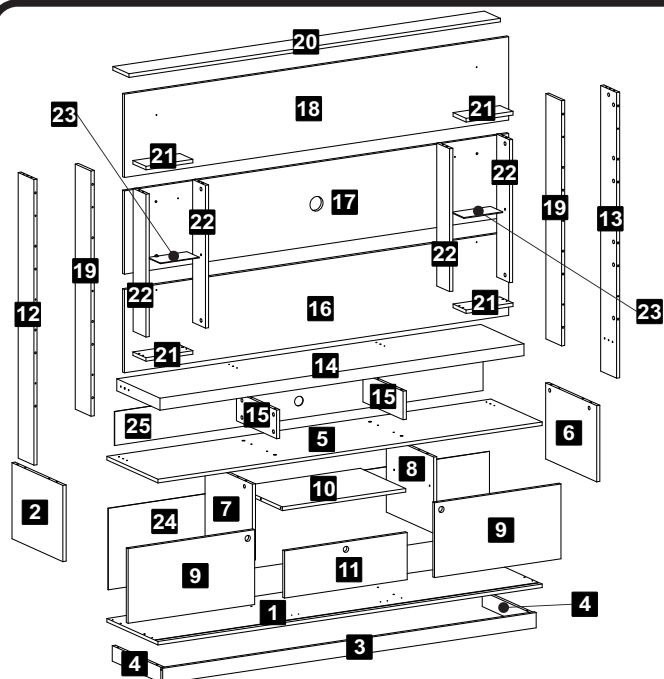

Descrição

- 1-Base (1800x415x15mm)
- 2-Lateral esq (320x413x15mm)
- 3-Encab. frontal (1750x65x15mm)
- 4-Encab. lateral (395x65x15mm)
- 5-Tampo int. (1800x415x15mm)
- 6- Lateral dir(320x413x15mm)
- 7-Divisão esquerda (320x384x15mm)
- 8-Divisão direita (320x384x15mm)
- 9-Porta lateral (592x314x15mm)
- 10-Prateleira inferior (578x367x15mm)
- 11-Porta central (574x198x15mm)
- 12-Lateral esq. sup. (1200x128x15mm)
- 13-Lateral dir. sup. (1200x128x15mm)
- 14-Tampo (1706x350x15mm)
- 15-Divisão sup. (120x325x15mm)
- 16-Painel inf. (1800x350x15mm)
- 17-Painel central (1800x350x15mm)
- 18-Painel superior (1800x350x15mm)
- 19-Travessa traseira (1030x128x15mm)
- 20-Prateleira traseira (1740x130x15mm)
- 21-Tampo/Base nicho (220x105x15mm)
- 22-Lateral nicho (600x104x15mm)
- 23-Prateleira vidro (182x100x3mm)
- 24-Traseira (1786x342x3mm)
- 25-Traseira menor (1726x143x3mm)

Descripción

- 1-Base
- 2-Lateral izquierda
- 3-Encabezado frontal
- 4-Encabezado lateral
- 5-Tapa intermediario
- 6-Lateral derecha
- 7-Division izquierda
- 8-Division derecha
- 9-Puerta lateral
- 10-Anaque inferior
- 11-Puerta central
- 12-Lateral izquierda superior
- 13-Lateral derecha superior
- 14-Tapa
- 15-Division superior
- 16-Panel inferior
- 17-Panel central
- 18-Panel superior
- 19-Travesaño trasera
- 20-Anaque trasera
- 21-Tapa/Base nicho
- 22-Lateral nicho
- 23-Anaque vidrio
- 24-Trasera
- 25-Trasera menor

Description

- 1-Base
- 2-Left side
- 3-Front header
- 4-Side header
- 5-Intermediary top
- 6-Right sid
- 7-Left partition
- 8-Right partition
- 9-Side door
- 10-Lower shelf
- 11-Center door
- 12-Upper left side
- 13-Upper right side
- 14-Top
- 15-Upper partition
- 16-Lower panel
- 17-Center panel
- 18-Upper panel
- 19-Back crosspiece
- 20-Back shelf
- 21-Top/Base nicho
- 22-Nicho side
- 23-Shelf Glass
- 24-Back
- 25-Smaller back

1 Passo
Paso
Step

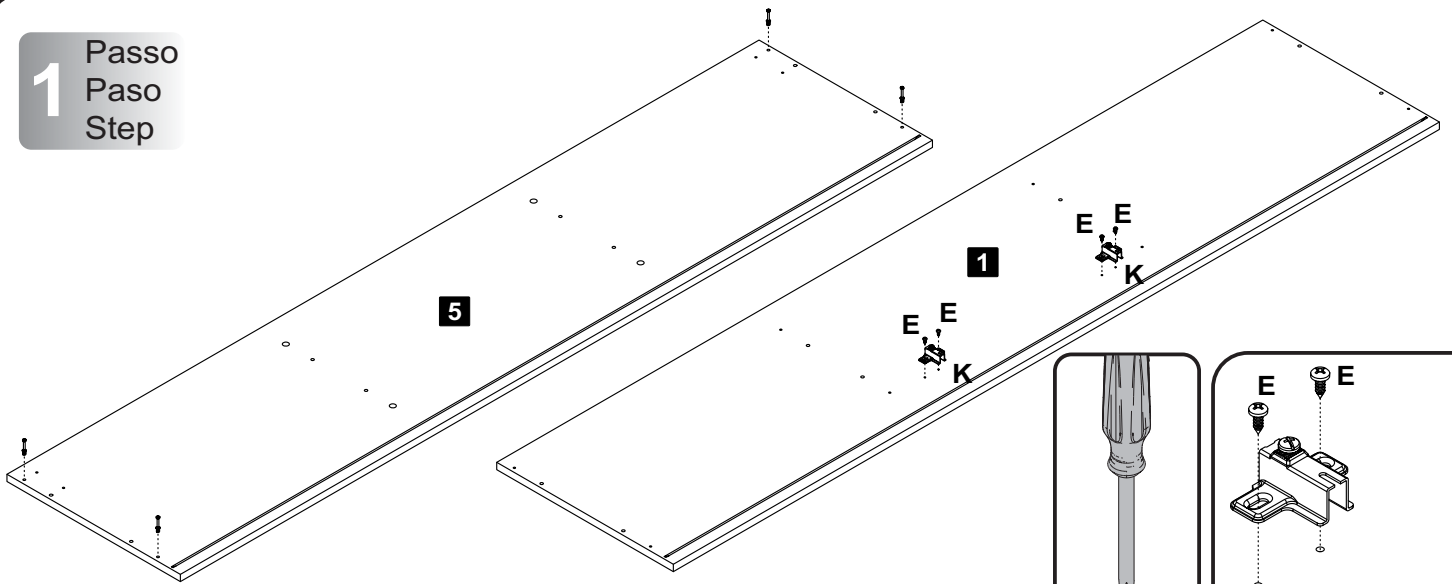

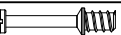
B  Minifix
Ø7x30mm **04**

E  Parafuso
Ø4,0x14mm CP **04**

K  Kit Dobradiça
Ata **02**

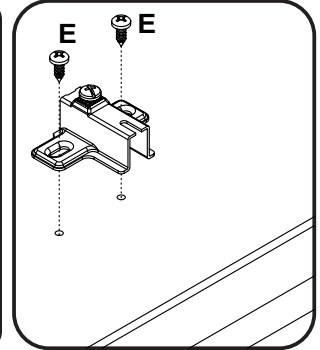
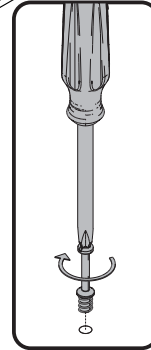

2 Passo
Paso
Step

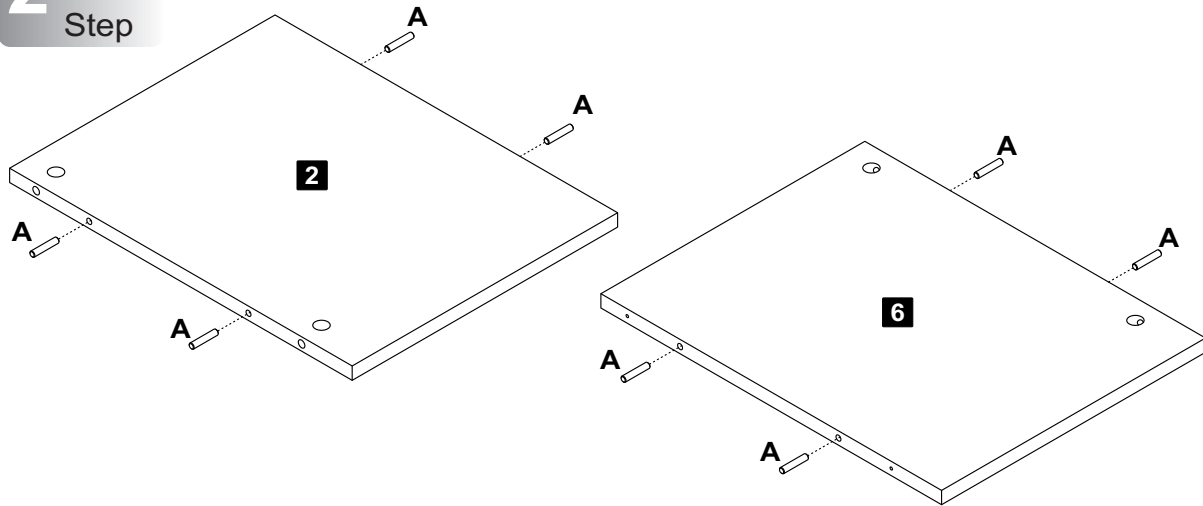

A  Cavilha **08**

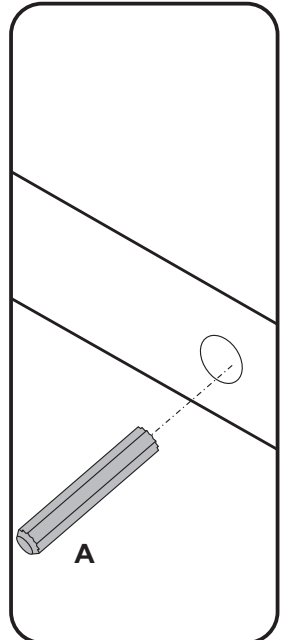

3 Passo
Paso
Step

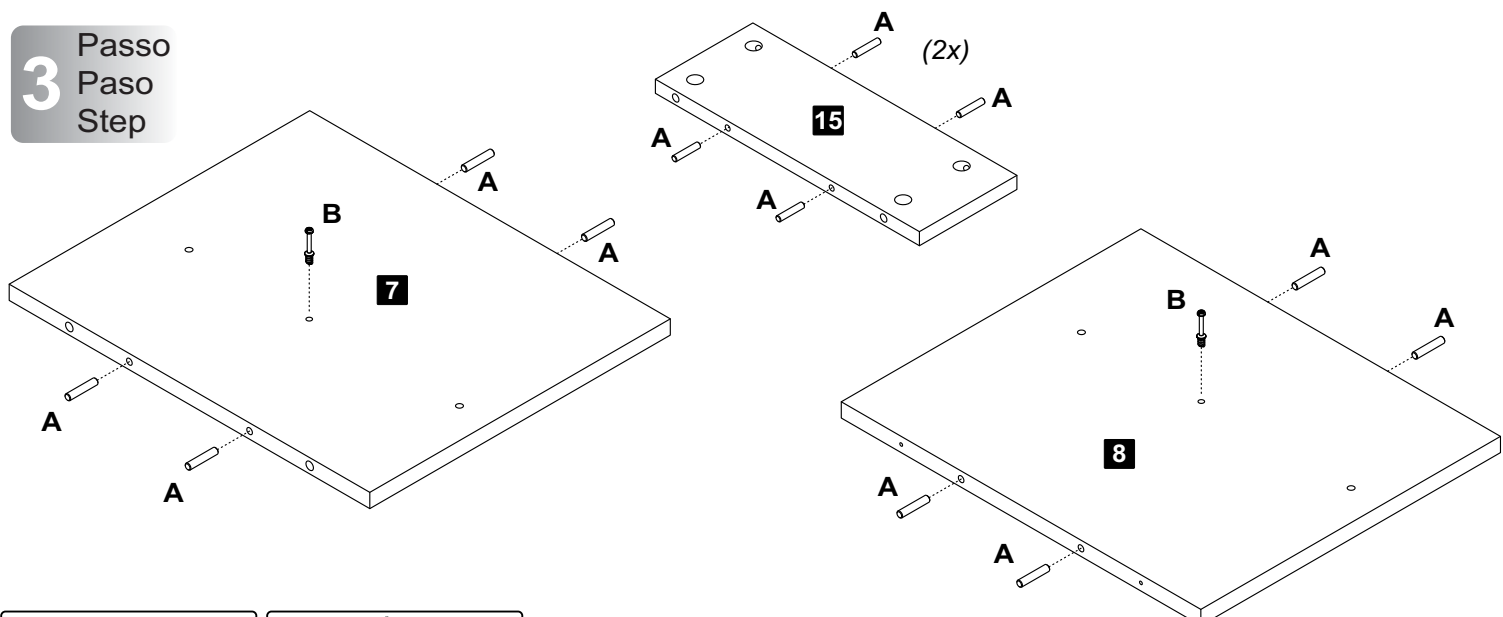

A  Cavilha **16**

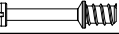
B  Minifix
Ø7x30mm **02**

4 Passo
Paso
Step

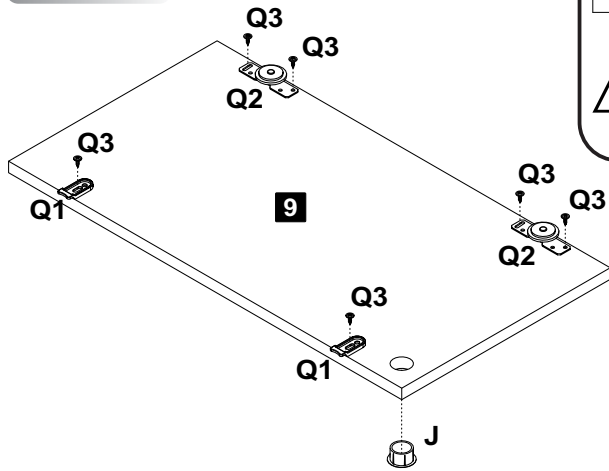

-Utilizar o gabarito da última folha para fixar o kit porta de correr.
-Use la plantilla de la última hoja para armar el Kit de la Puerta Deslizante.
-Use the Door Mounting template in the last page to attach the sliding door kit.

5mm

-Colocar o parafuso centralizado no furo oblongo para poder ajustar.
-Coloque el tornillo en el centro del orificio oblongo para que pueda ajustarlo.
-Put the screw centralized in the oblong hole.

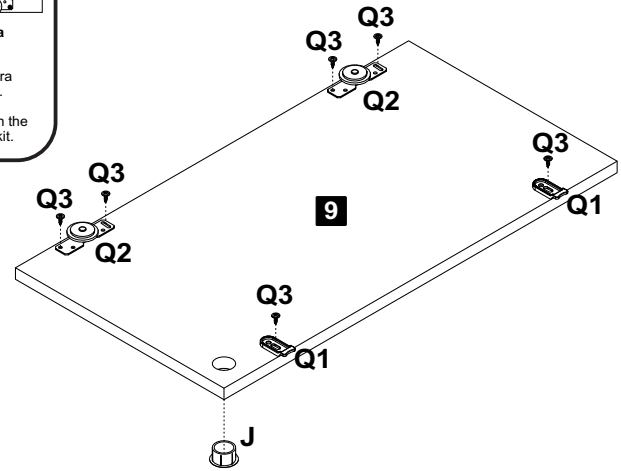

- J** Puxador **01**
- Q1** Guia **04**
- Q2** Roldana **04**
- Q3** Parafuso Ø3,5x12mm CF **12**

5 Passo
Paso
Step

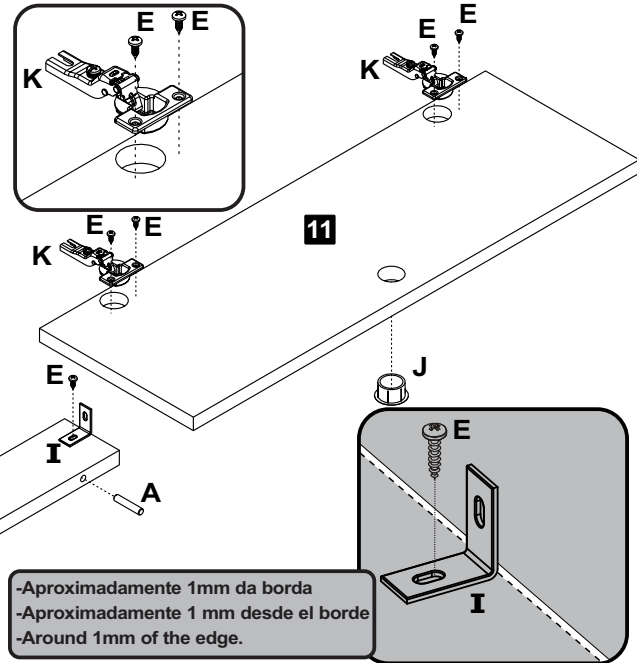
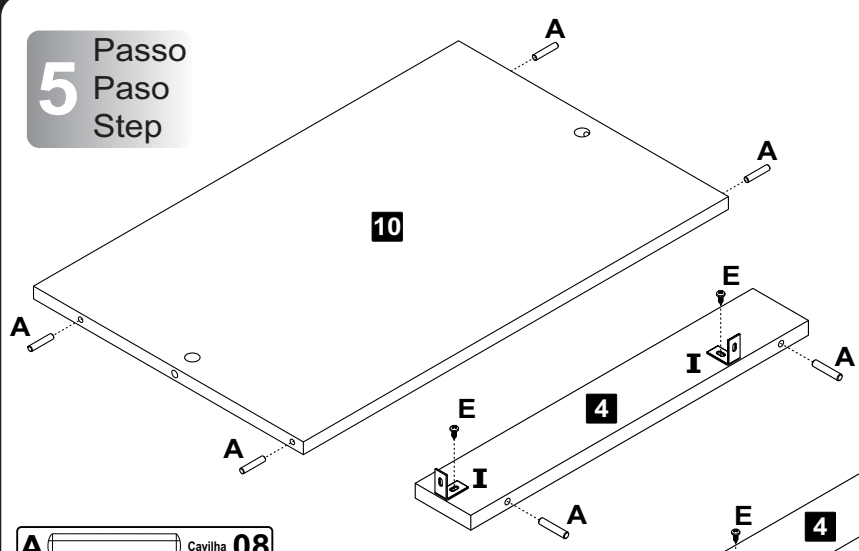

- A** Cavilha **08**
- E** Parafuso Ø4,0x14mm CP **08**
- J** Puxador **01**
- I** Cantoneira **04**
- K** Kit Dobradiça Ata **02**

-Aproximadamente 1mm da borda
-Aproximadamente 1 mm desde el borde
-Around 1mm of the edge.

6 Passo
Paso
Step

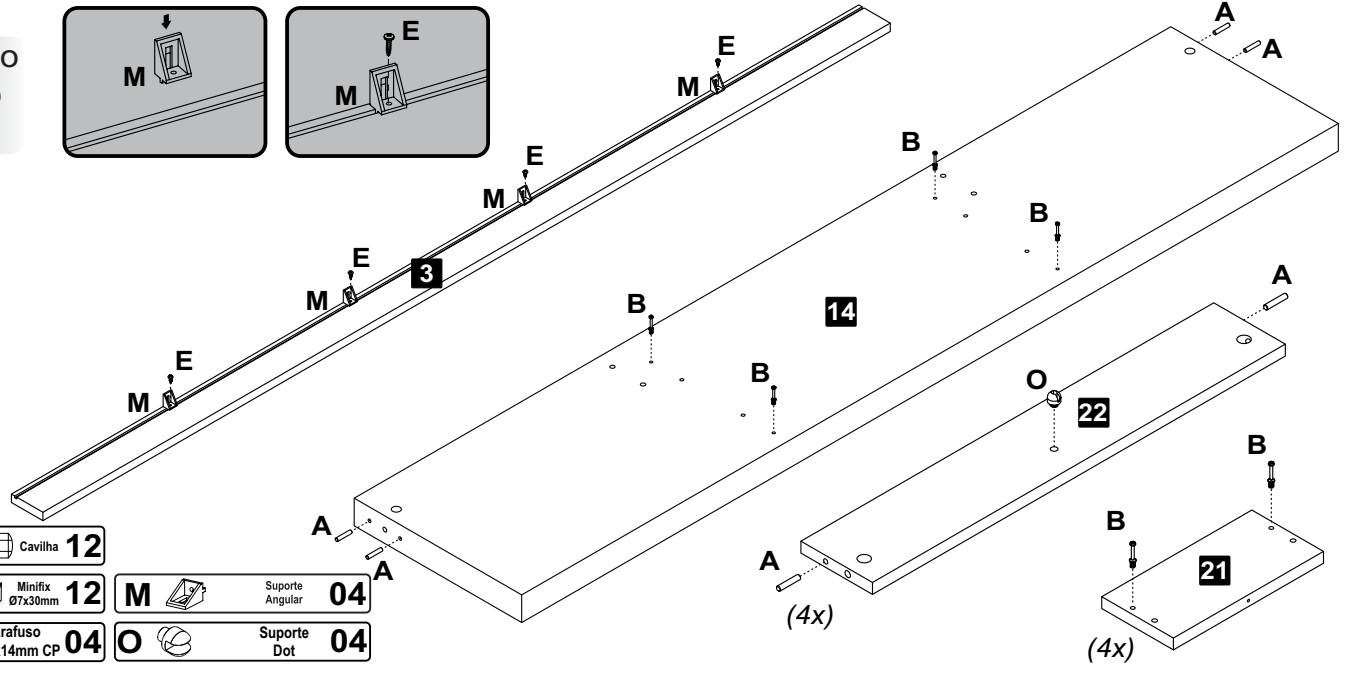
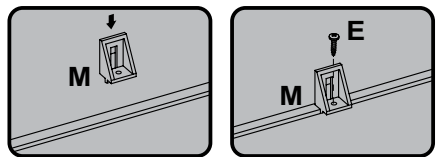

- A** Cavilha **12**
- B** Mini-fix Ø7x30mm **12**
- M** Suporte Angular **04**
- E** Parafuso Ø4,0x14mm CP **04**
- O** Suporte Dot **04**

(4x)

(4x)

7 Passo
Paso
Step

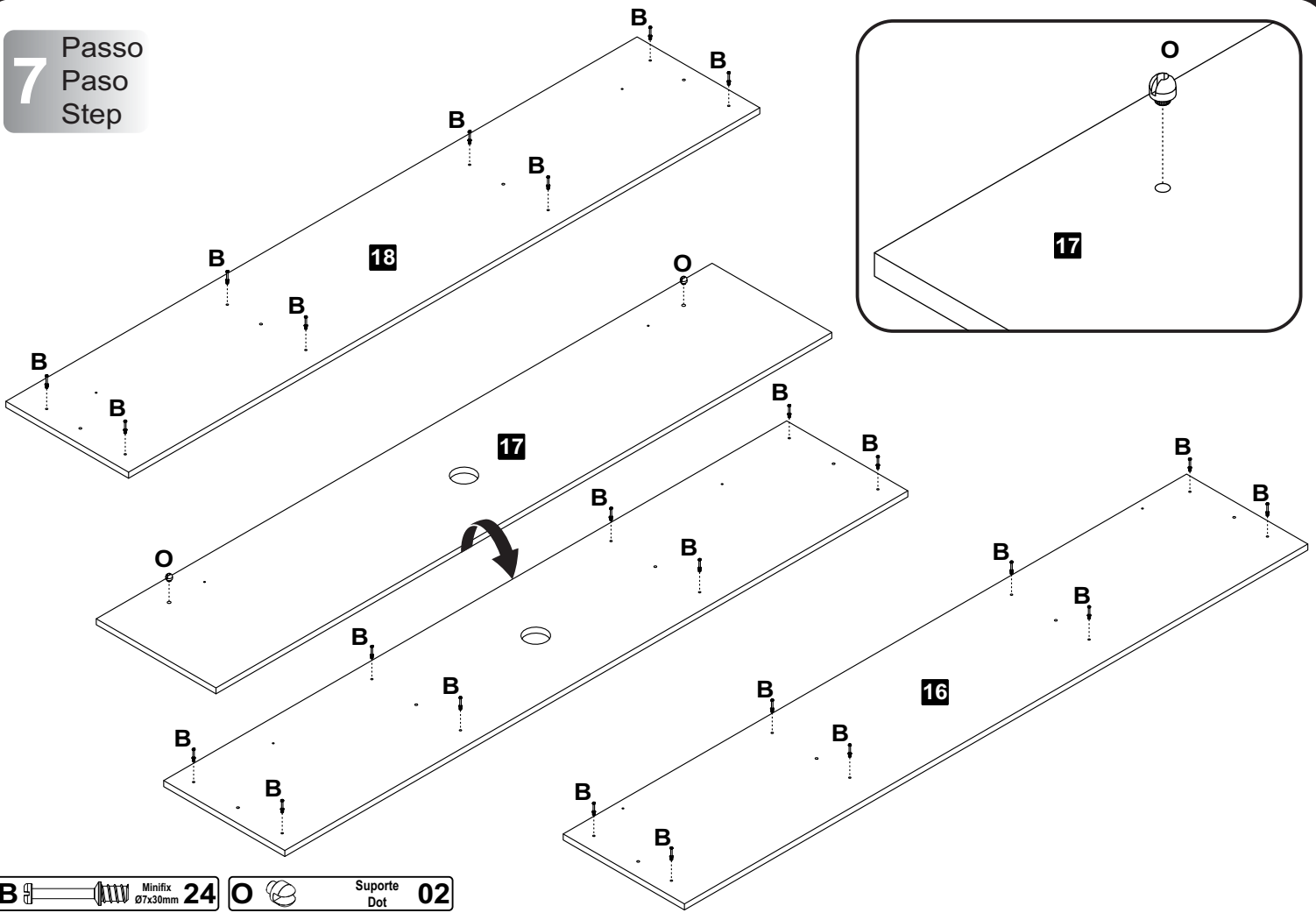

8 Passo
Paso
Step

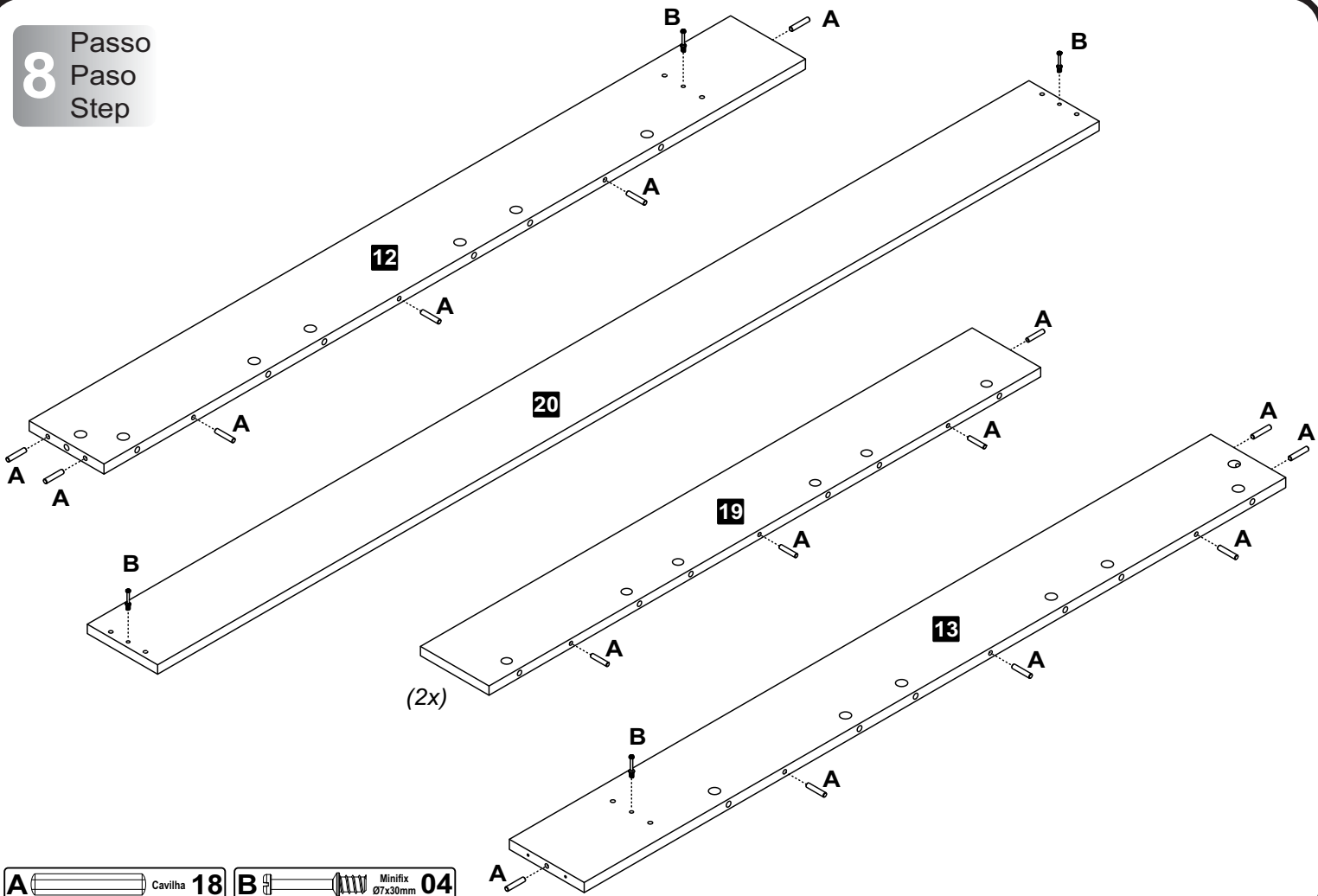

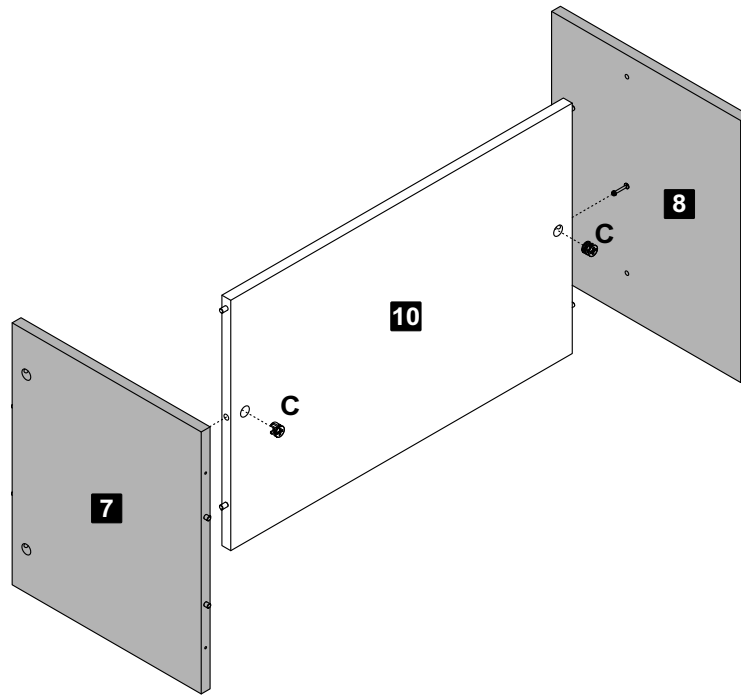

9 Passo
Paso
Step

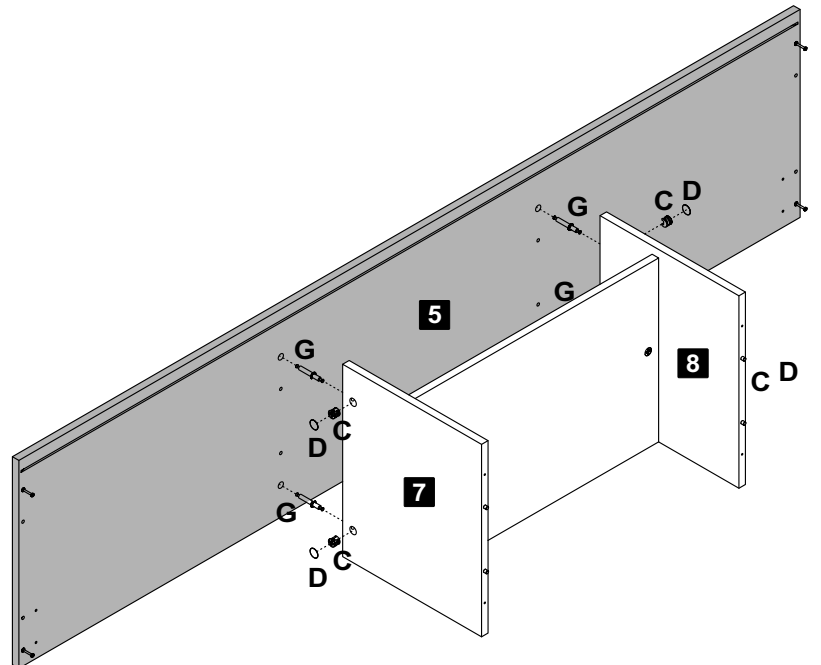
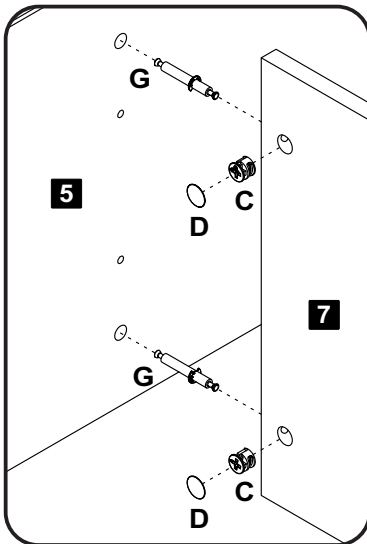
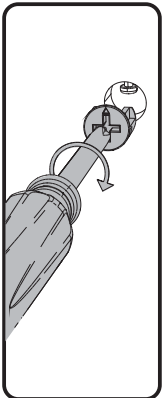

C  Tambor **02**

10 Passo
Paso
Step





C  Tambor **04**

D  Tapa Furo Adesivo **04**

G  Haste Dupla Minifix **04**

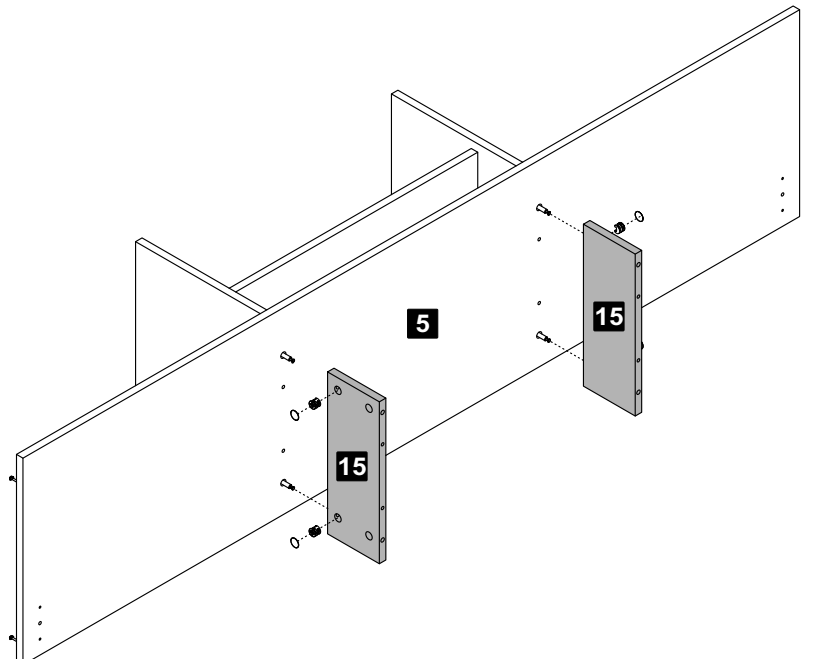
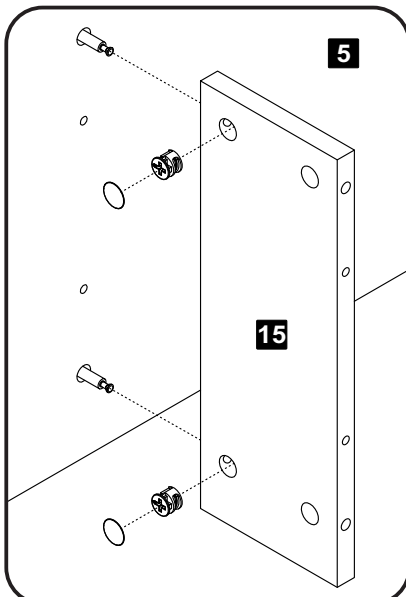
11 Passo
Paso
Step



C  Tambor **04**

D  Tapa Furo Adesivo **04**

12 Passo
Paso
Step

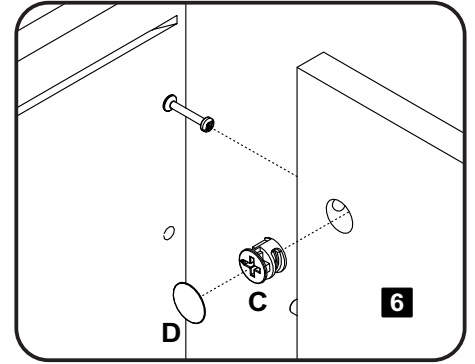
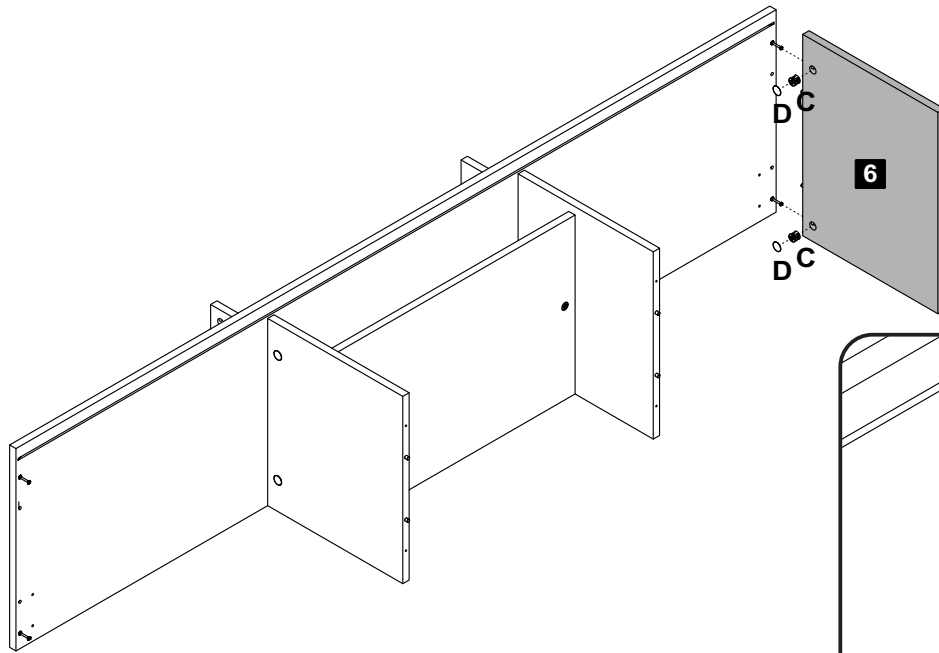

C  Tambor 02 D  Tapa Furo Adesivo 02

13 Passo
Paso
Step

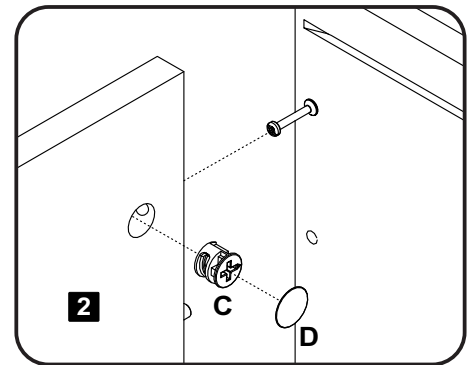
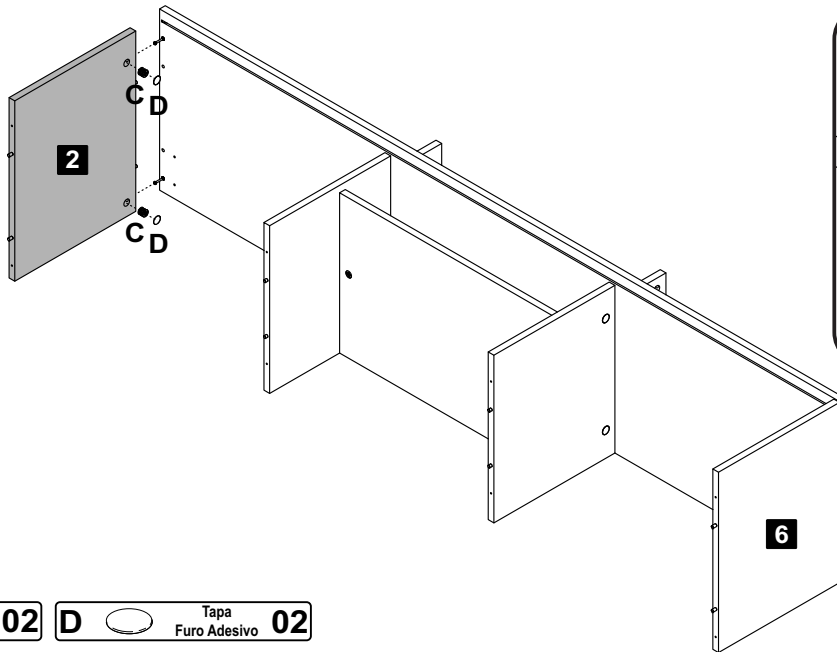

C  Tambor 02 D  Tapa Furo Adesivo 02

14 Passo
Paso
Step

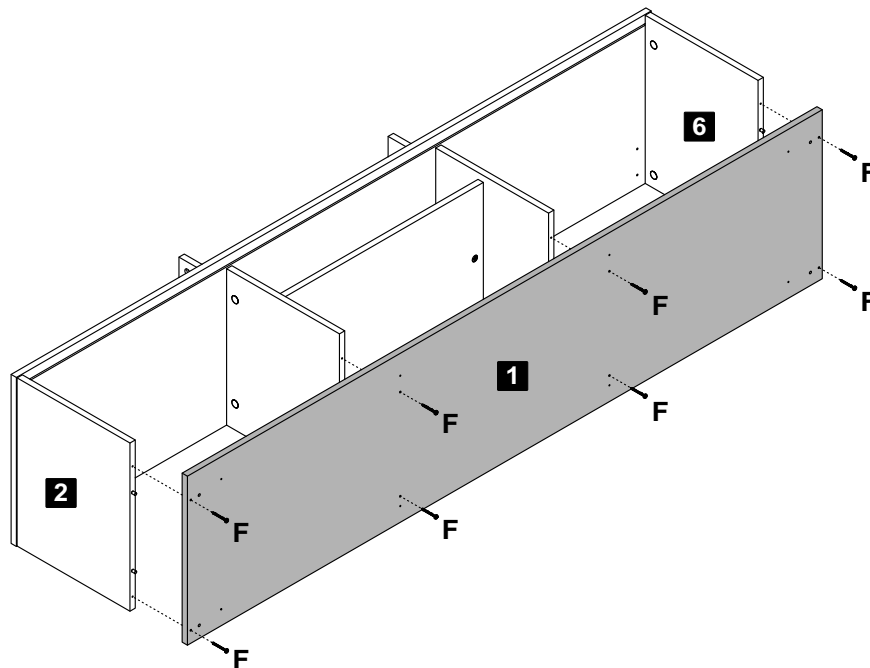

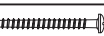
F  Parafuso Ø3,5x40mm CP 08

15 Passo
Paso
Step

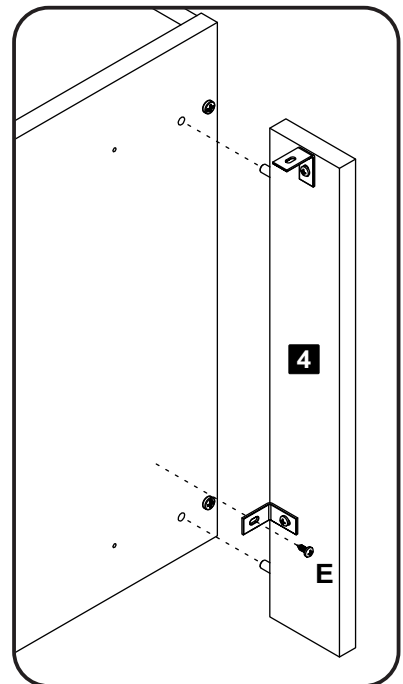
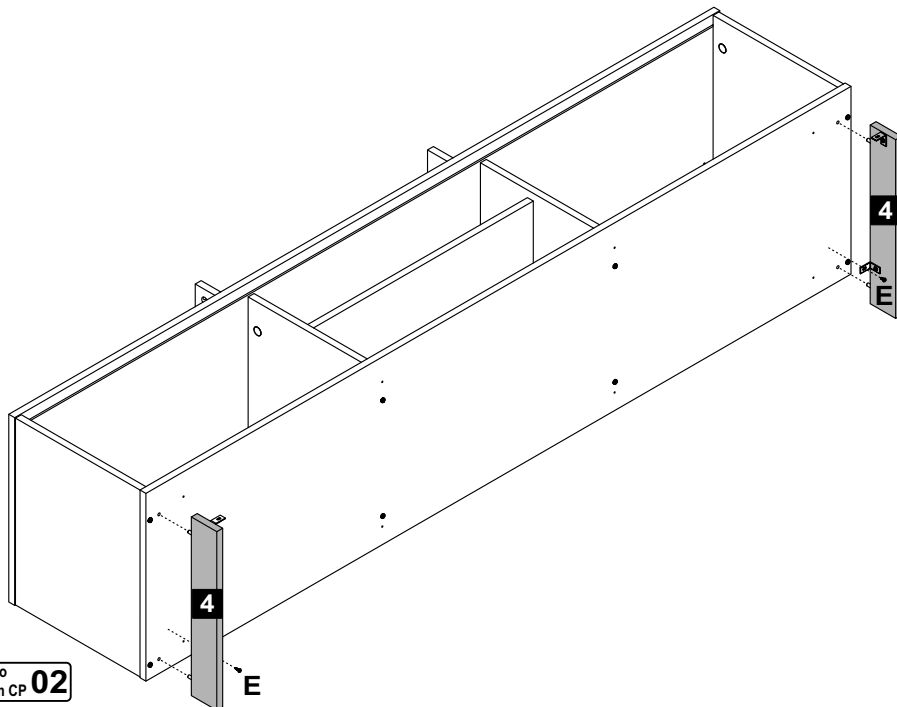

E  Parafuso
Ø4,0x14mm CP **02**

16 Passo
Paso
Step

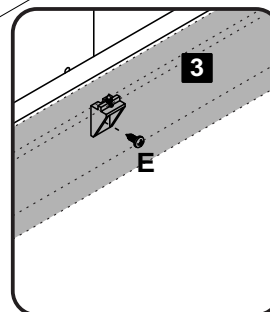
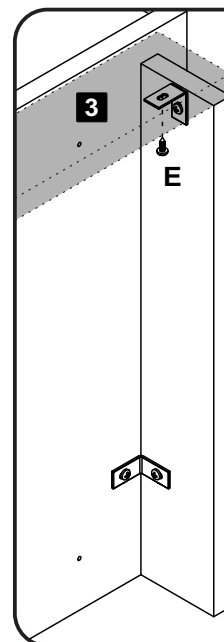
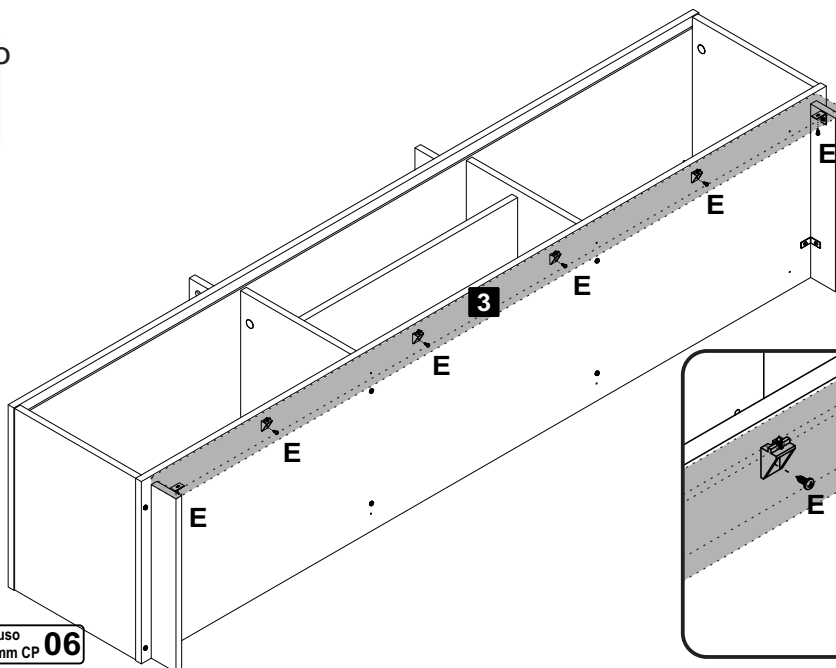

E  Parafuso
Ø4,0x14mm CP **06**

17 Passo
Paso
Step

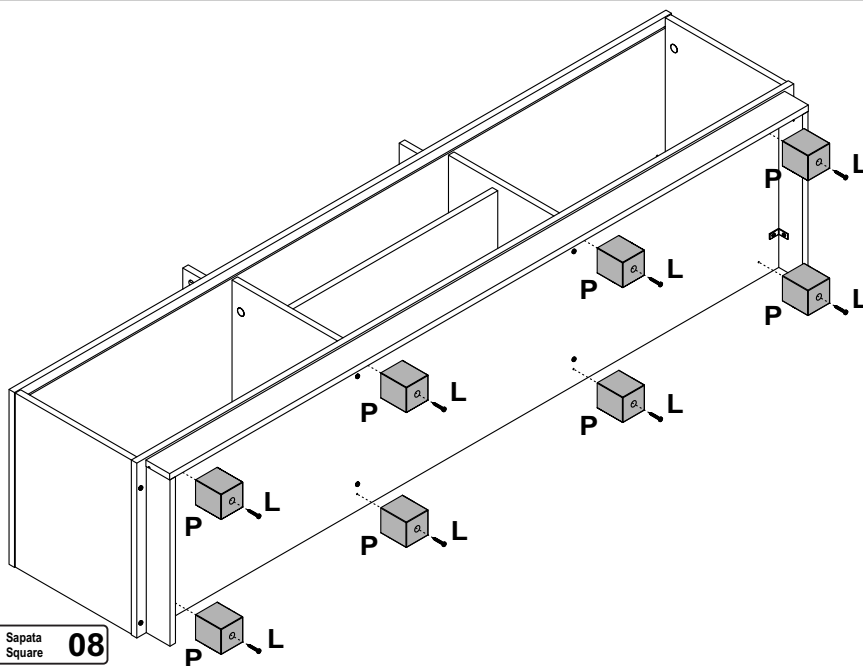

L  Parafuso
Ø4x20mm CP **08**

P  Sapata
Square **08**

18 Passo
Paso
Step

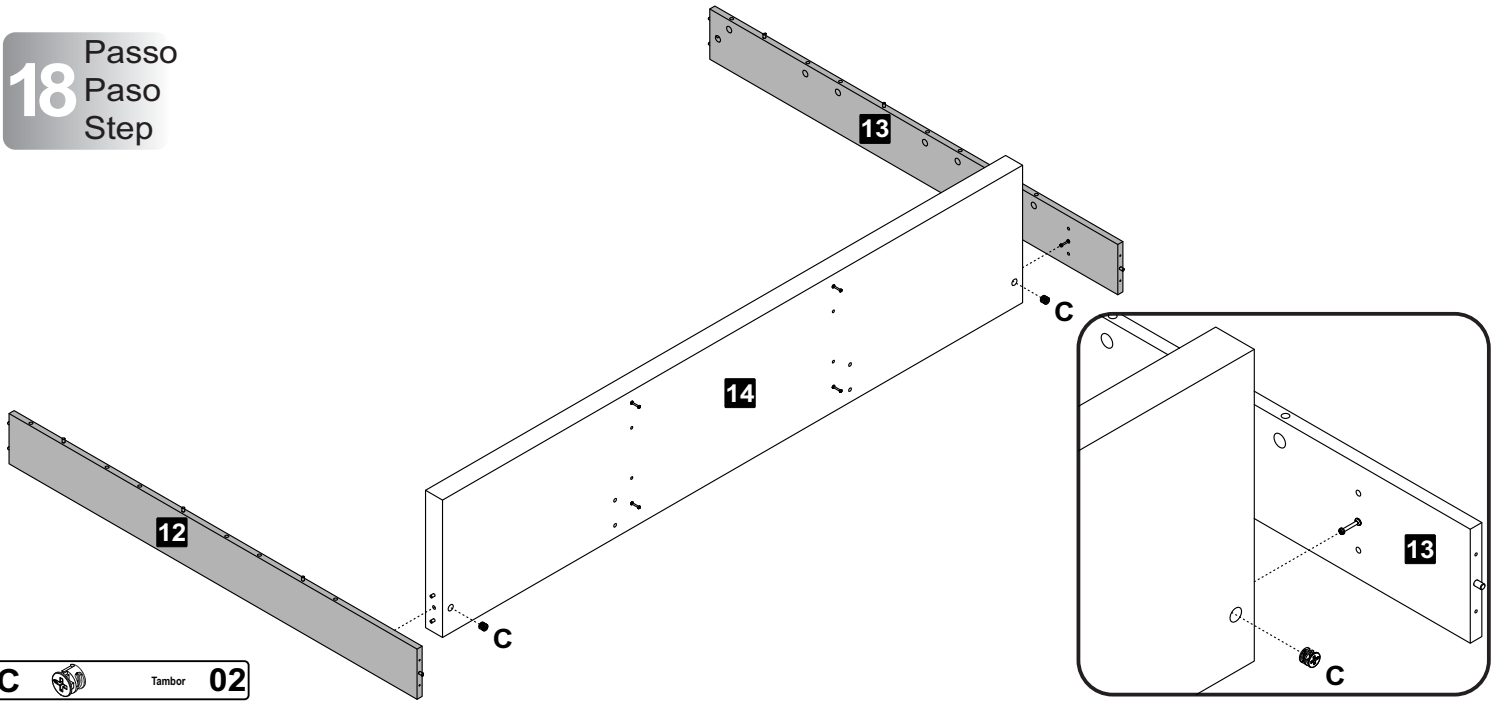

C  Tambor 02

19 Passo
Paso
Step

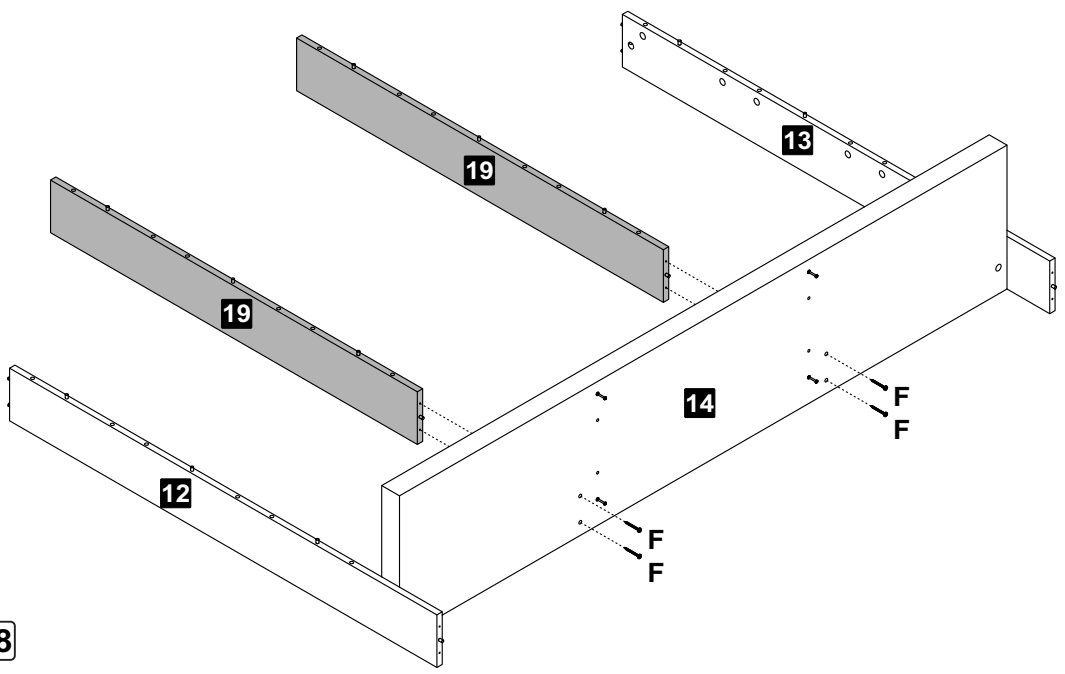

F  Parafuso Ø3,5x40mm CP 08

20 Passo
Paso
Step

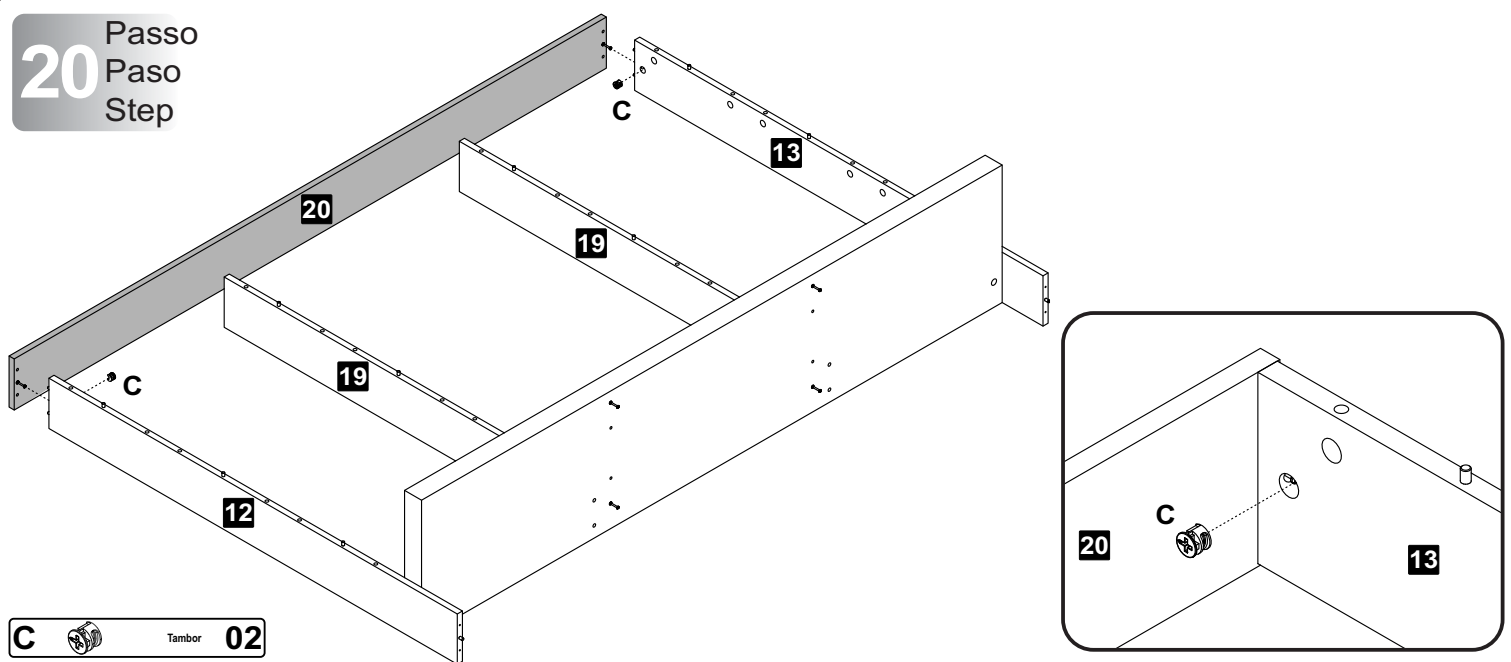

C  Tambor 02

21 Passo
Paso
Step

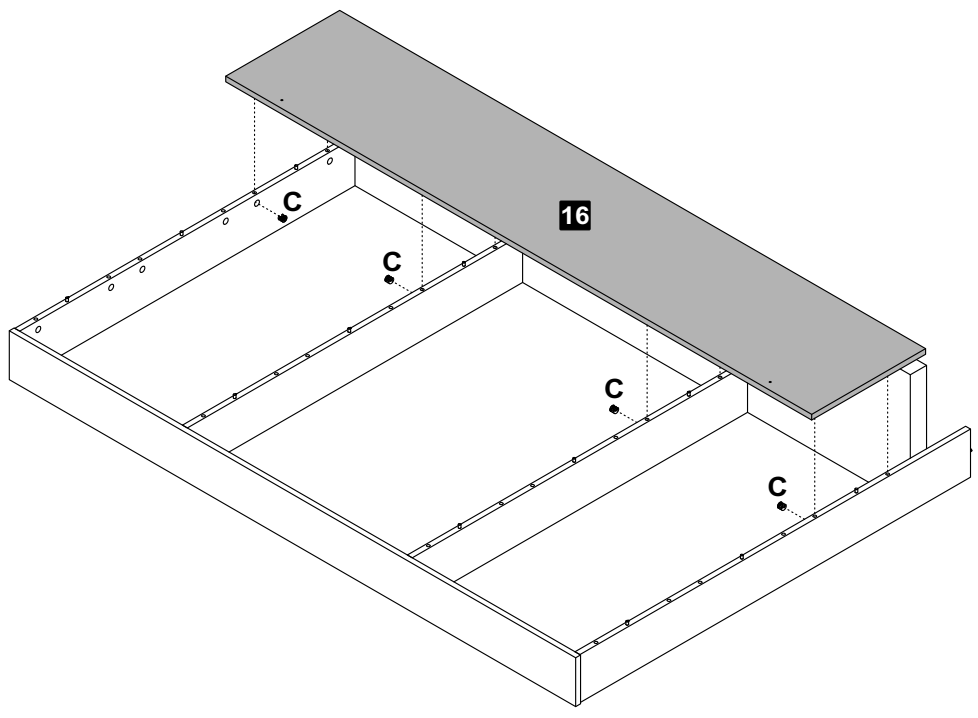
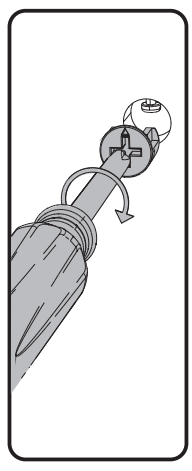

C  Tambor **04**

22 Passo
Paso
Step

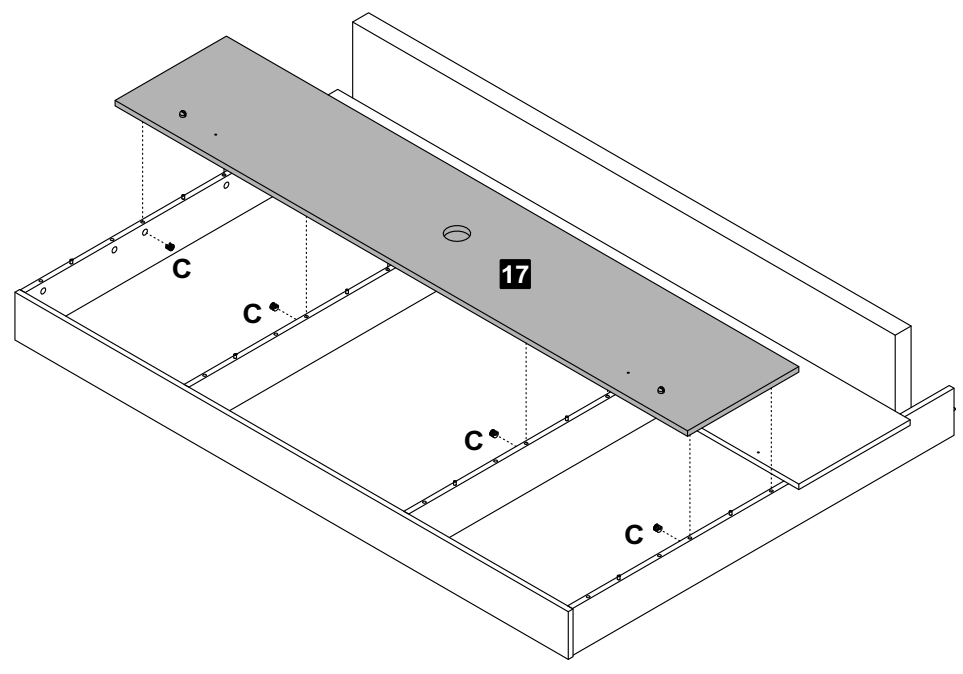

C  Tambor **04**

23 Passo
Paso
Step

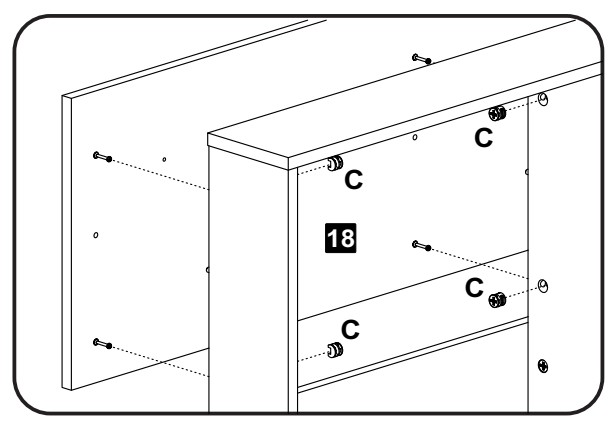
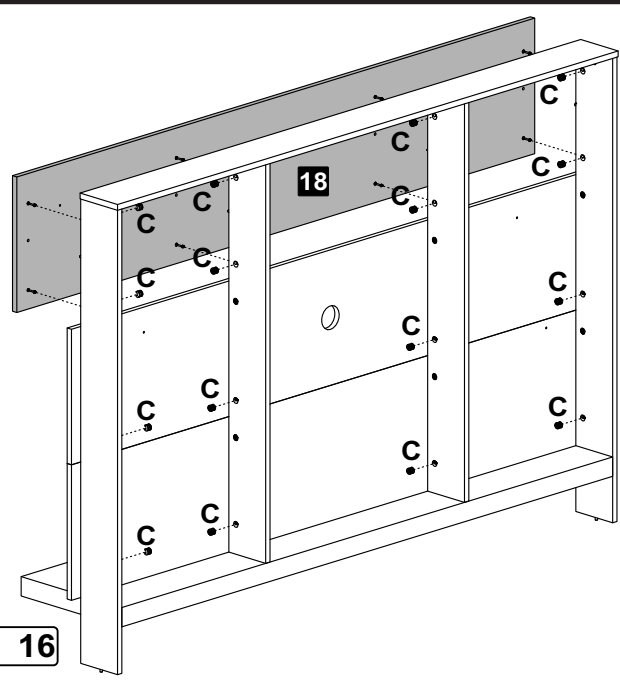

C  Tambor **16**

24 Passo
Paso
Step

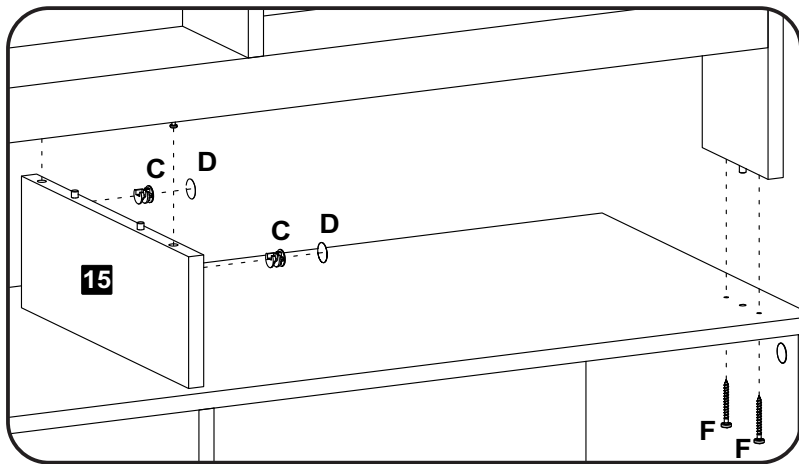

C Tambor **04** **D** Tapa Furo Adesivo **04** **F** Parafuso Ø3,5x40mm CP **04**

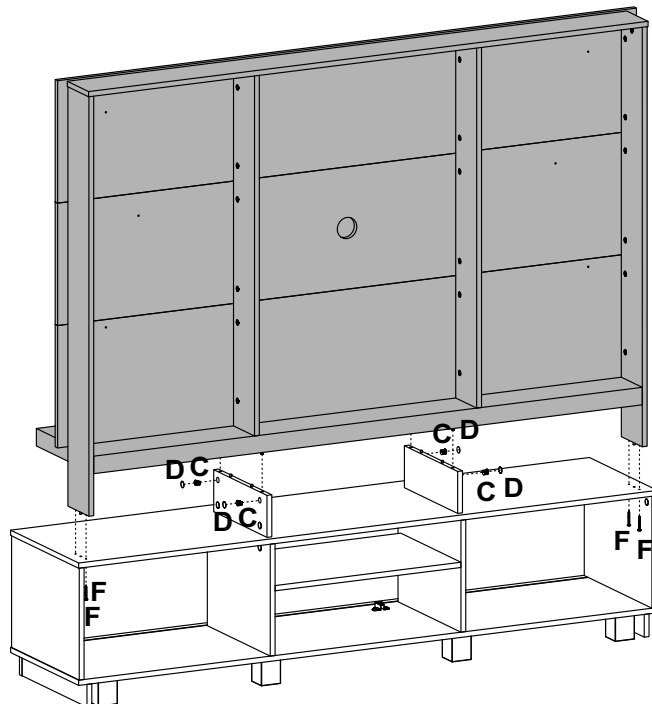

25 Passo
Paso
Step

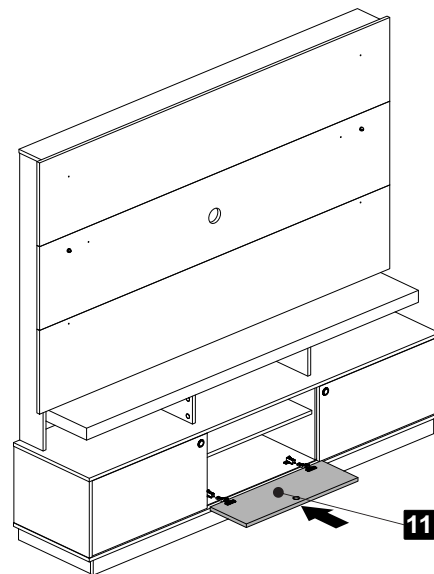
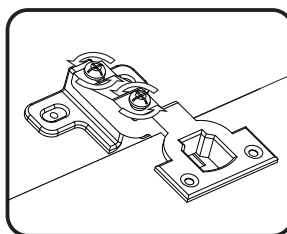
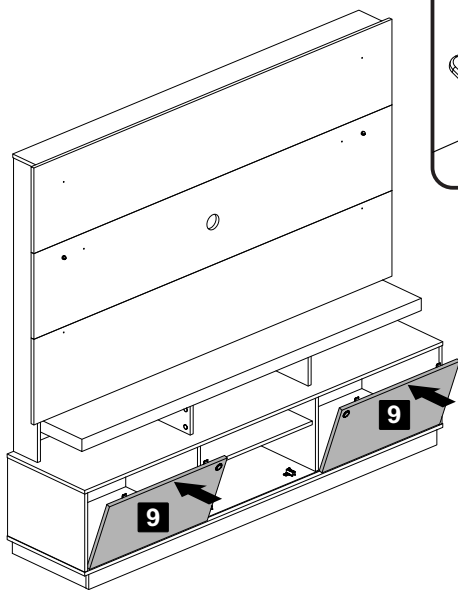
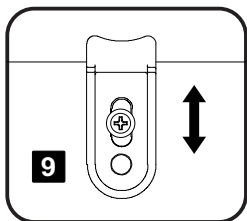

26 Passo
Paso
Step

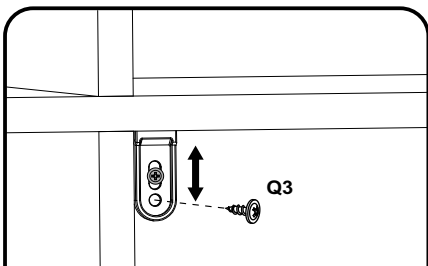

-Antes de finalizar colocando a traseira, ajuste as guias da porta para que a mesma fique deslizando corretamente, por final fixe por completo como no detalhe.
-Antes de colocar la parte trasera, ajuste las guías de la puerta para que la misma deslice correctamente.
-Before attaching the back, adjust the door guides to slide properly.

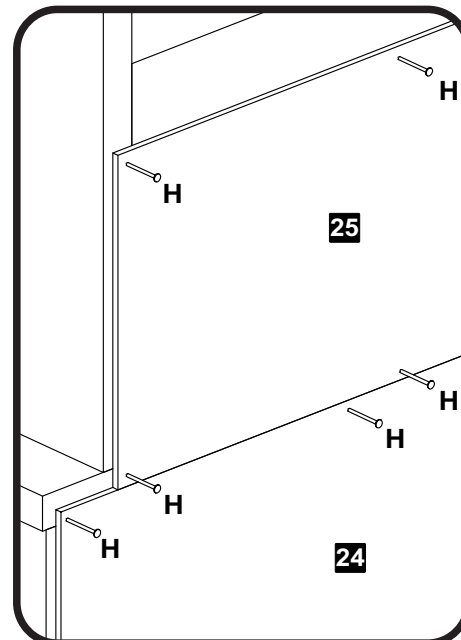
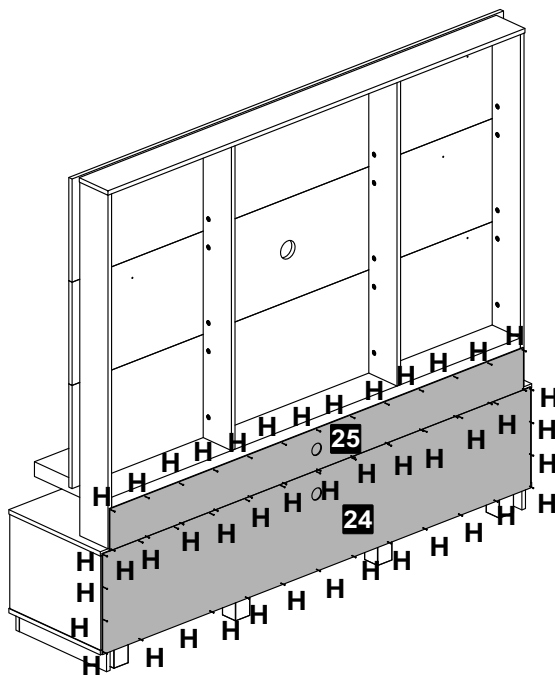

H Prego **56**

27 Passo
Paso
Step

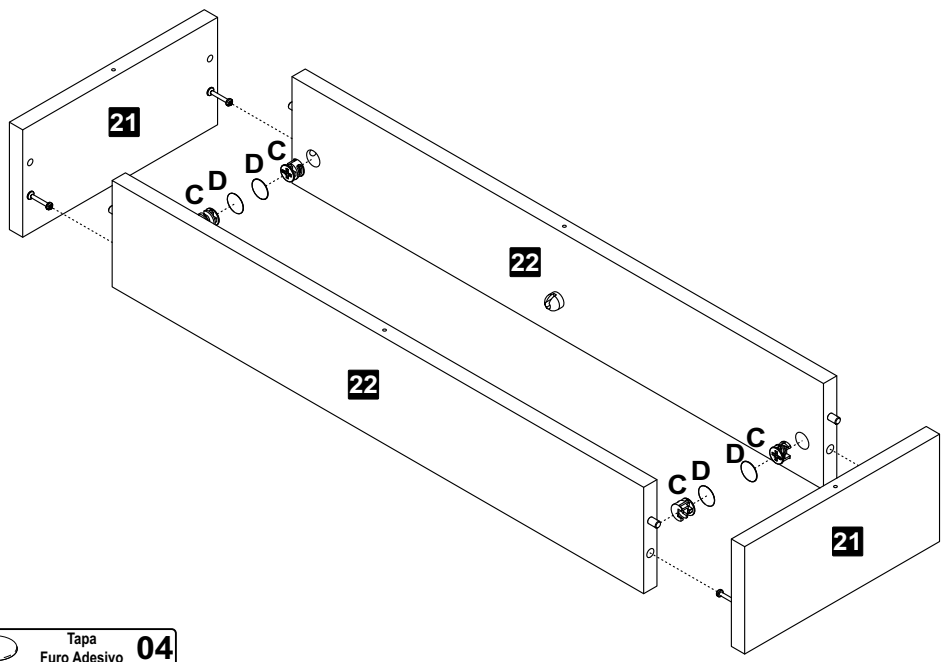

- C**  Tambor **04**
- D**  Tapa Furo Adesivo **04**

28 Passo
Paso
Step

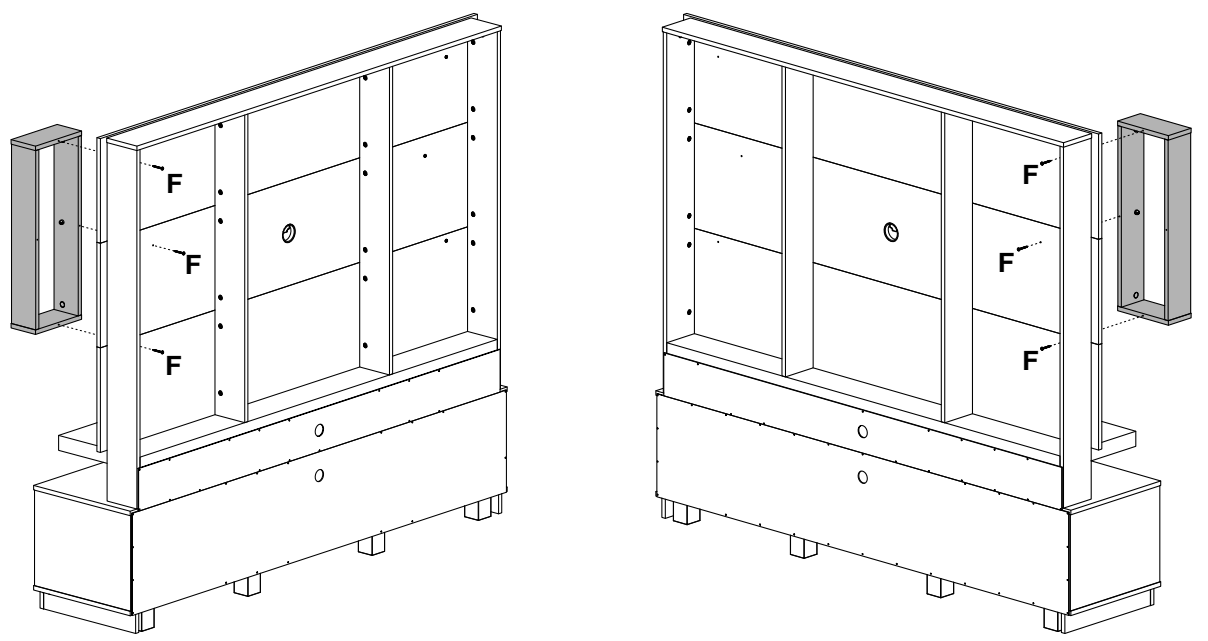

- F**  Parafuso Ø3,5x40mm CP **06**

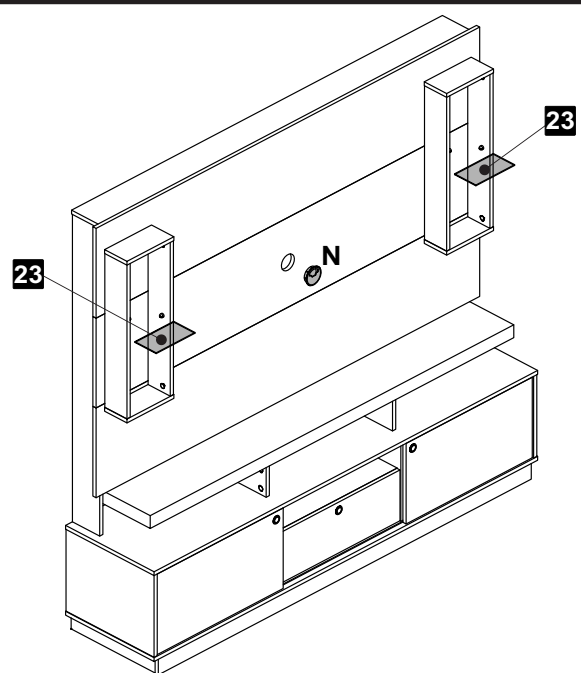

29 Passo
Paso
Step



- N**  Passa Fio Ø60mm **01**

27

Passo
Paso
Step

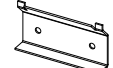
kit suporte TV kit soporte para TV / TV support kit				
R				2
	R6	Parafuso / Tornillo / Screw M6 x 16		4
	R7	Parafuso / Tornillo / Screw M8 x 16		4



-Para facilitar a fixação do Suporte Universal, enviamos 2 modelos de parafusos que estão de acordo com os padrões mais usados pelos principais fabricantes de TVs LCD / LED / PLASMA / 3D do mercado. Caso nenhum dos 2 modelos se encaixe adequadamente ao seu televisor, adquira o parafuso compatível com sua TV em qualquer loja de ferragens. Para evitar danos à sua TV, não aperte demasiadamente os parafusos.

-Para facilitar la colocación del soporte universal, enviamos 2 modelos de tornillos que cumplen con los estándares más utilizados por los principales fabricantes de televisores. Si ninguno de los modelos se ajusta a su televisor correctamente, compre el tornillo compatible con su televisor en cualquier ferretería. Para evitar daños a su televisor, no apriete demasiado los tornillos.

-To make it easier to attach the TV support, we send 2 screw models that match the most commonly used TVs. If neither model fits your TV properly, purchase the compatible screw from any hardware store. To prevent damage to your TV, do not over tighten the screws.

28

Passo
Paso
Step



Utilizar a Norma VESA do manual da TV, para calcular a centralização e altura da TV no painel.

Use el estándar VESA del manual del televisor para calcular el centrado y la altura del televisor en el panel.

Use the VESA Standard from the TV manual to calculate the centering and height of the TV on the panel.

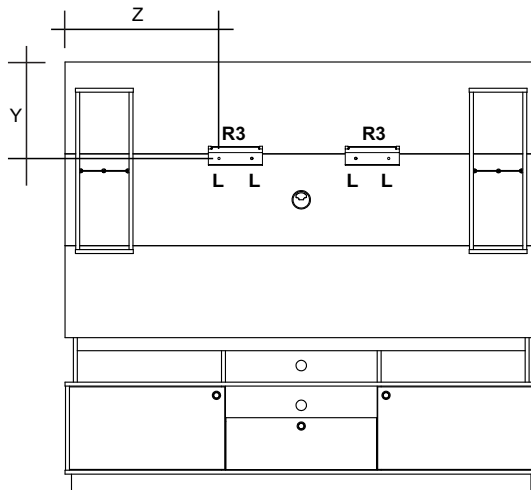

Utilizar o parafuso indicado no manual da TV R6 / R7(VESA).
Use el tornillo indicado en lo manual del televisor R6 / R7(VESA).
Use the screw indicated in the TV manual R6 / R7(VESA).

Suporte Superior Soporte superior / Upper support

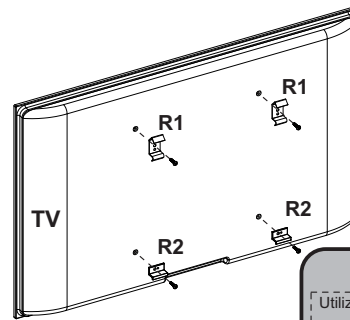
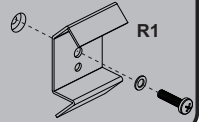

Suporte Inferior Soporte inferior / Lower support

Utilizar o parafuso indicado no manual da TV R6 / R7(VESA).
Use el tornillo indicado en lo manual del televisor R6 / R7(VESA).
Use the screw indicated in the TV manual R6 / R7(VESA).

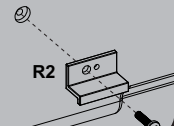

Parafuso 04
Ø4,0x30mm CP

R3 Kit Suporte TV 02

R1 Kit Suporte TV 02

R2 Kit Suporte TV 02

29

Passo
Paso
Step

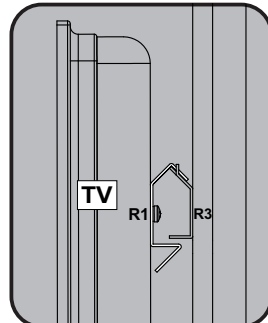
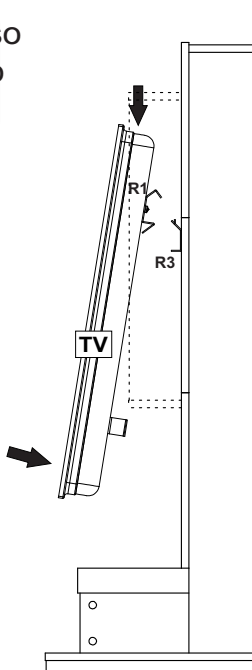

Garantia

Este certificado de Garantia é uma vantagem adicional oferecida ao consumidor, porém para que o mesmo tenha validade é imprescindível que seja apresentada a NOTAFISCAL de compra do produto.

Com este produto, a Artely tem como objetivo atender plenamente o proprietário-consumidor, proporcionando a garantia na forma aqui estabelecida, pelo período de três meses a partir da data da nota fiscal de compra. A Artely restringe a sua responsabilidade à substituição gratuita das peças defeituosas, em caso de defeitos ou avarias devidamente constatados como sendo de fabricação, durante a vigência desta garantia.

A Artely declara a garantia nula e sem efeito se o produto for alterado, adulterado, molhado ou consertado e ainda pela prática de montagem inadequada ou mau uso. Também será considerada nula em casos de força maior, como aqueles causados por agentes da Natureza (chuvas, incêndios, excesso de umidade, cupins...) e eventos externos como objetos arrastados sobre a superfície do móvel (ex.: TV, DVD, aparelho de som, objetos decorativos...).

Para exercer seus direitos de comprador é importante que antes de montar seu produto você leia com atenção as instruções de cada passo do manual de montagem que acompanha o móvel.

Caso o produto não esteja em conformidade, entre em contato com a loja onde efetuou a compra ou com o nosso Serviço de Atendimento ao Cliente através do e-mail assistencia@artely.com.br ou pelo fone 41 3381 5000 e faça sua reclamação, apontando os defeitos técnicos observados, que teremos o maior prazer em atendê-lo. Para agilizar o seu atendimento, tenha sempre em mãos o manual de montagem com os respectivos números das peças defeituosas, conforme descritas no manual.



ARTELY MÓVEIS LTDA
ALAMEDA ARPO, 2333
CEP / ZIP CODE: 83010-290
SÃO JOSÉ DOS PINHAIS
CURITIBA - PR - BRASIL
Fone / Fax: 41 3381-5000
Phone Number: 55 41 3381-5000
e-mail: artely@artely.com.br
www.artely.com.br

Gabarito da Porta
Plantilla de la Puerta / Door Mounting Template
Home Sevilha

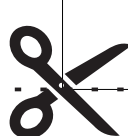
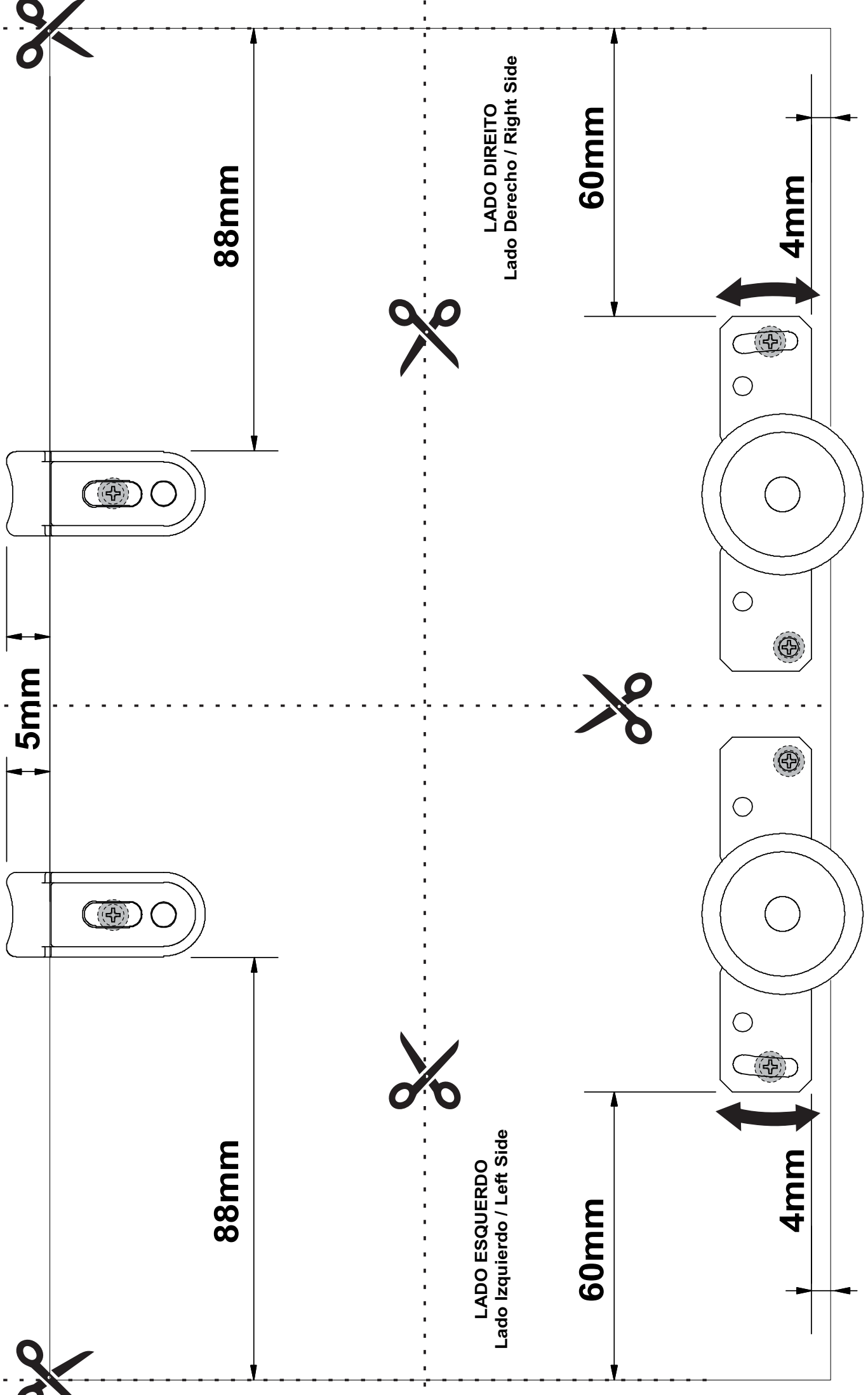

88mm

88mm

60mm

60mm

4mm

4mm

LADO ESQUERDO
Lado Izquierdo / Left Side

LADO DIREITO
Lado Derecho / Right Side

5mm

